

# ZL41 Cell

1.0 rev Monday, December 12, 2022



## User Guide

For model: 4.2, 5.5, Liquid & Air cooled, USB & CameraLink

© Andor Technology 2022

---

# Section 1 - Safety and Warning Information

## Caution



**PLEASE READ THIS INFORMATION FIRST BEFORE USING YOUR PRODUCT**

1. If the equipment is used in a manner not specified by Andor, the protection provided by the equipment may be impaired.
2. Do not position this product so that it is difficult to operate the mains disconnecting device. See "[Emergency Mains Disconnection](#)" on page 49.
3. Before using the product, please follow and adhere to all warnings, and safety, manual handling, and operating instructions located either on the product, or in this manual.
4. Keep this manual in a safe place for future reference.
5. Users must be authorised and trained personnel only; otherwise, this may result in personal injury, and/or equipment damage and impaired system performance.
6. There are no user-serviceable parts inside the product and the enclosure must not be opened. Only authorised service personnel may service this equipment.
7. If using liquid cooling, ensure that the coolant supply is connected prior to powering the camera. Please also read all of the information relating to the use of coolant in "[Cooling Hoses and Connections](#)" on page 136.
8. Protective earth is an integral part of the protection against electric shock in this product and is provided via the earth pin of the external power supply. Ensure that this is plugged into the building earth system via the mains socket. Do not tamper with any of the earthing measures.
9. Any External AC/DC Power Supply used with this product must meet the requirements specified in "[Power Supply Information](#)" on page 146.

- 
10. No parts should be replaced by the customer, except for the mains cables or the fuse, which must be of the same type and rating as that supplied and as specified in ["Power Supply Information" on page 146](#) or ["Fuse Replacement" on page 132](#), and certified in accordance with your region's safety regulations.
  11. Make sure all cables are located so that they will not be subject to damage, especially the mains cable.
  12. While running an experiment, keep room temperature as stable as possible.
  13. Performance of the system may be adversely affected by rapidly changing environmental conditions or operation outside of the operating conditions specified in ["Technical Specifications" on page 140](#).
  14. Ensure that adequate ventilation is provided as specified in ["Environmental Specifications" on page 144](#).
  15. This product is designed to be used in an indoor environment. If the customer chooses to use this outside, then it is their responsibility to provide adequate protection. Andor assumes no liability for damage or obligation to repair under warranty relating to use outside of the environmental requirements specified in ["Technical Specifications" on page 140](#).
  16. Medical Diagnosis: This equipment has not been designed and manufactured for the medical diagnosis of patients.
  17. Electromagnetic Compatibility (CameraLink 10-tap Variant) – Caution: This product was designed for and tested using the IEC/EN 61326-1 EMC standard for Class A emissions and a Basic immunity environment. Class A means that it is not designed for a domestic or residential environment, and Industrial immunity refers to the fact that it is designed to cope with the interference found in a typical industrial environment This equipment is not intended for use in residential environments and may not provide adequate protection to radio reception in such environments.
  18. Electromagnetic Compatibility (USB3 Variants): This product was designed for and tested using the IEC/EN 61326-1 EMC standard for Class B emissions and a Industrial immunity environment. Class B means that it is designed for a domestic or residential environment, and Industrial immunity refers to the fact that it is designed to cope with the interference found in a typical industrial environment.





- 
19. Electromagnetic Compatibility: As required by IEC/EN 61326-1, we must inform you that electromagnetic emissions in excess of that required by that EMC standard for the emissions class of this product can in theory occur due to its connection to other equipment.
  20. EMC Permissible Loss of Performance (USB3 Variant Only): This product complies with international EMC standards, but please note that this includes a permissible loss of performance as allowed by IEC/EN 61326-1:2021 for a highly unlikely event that could theoretically occur during 4 kV contact ESD strikes: 1 frame of in-transit data (i.e. not stored data) may be lost during a transaction. This issue has never been seen during normal use and theoretical probability decreases with decreasing speed, i.e. probability of occurrence during full-bandwidth kinetic series is extremely unlikely, but occurrence during software-triggered frames is almost impossible.
  21. Electromagnetic Compatibility: This product has been designed and tested to perform successfully in a normal (basic) electromagnetic environment, e.g. a typical life science test laboratory, as per the EU EMC Directive. It is not designed to operate in a harsh electromagnetic environment, e.g. close to the following equipment: EMI/RFI generators, electrostatic field generators, electromagnetic or radioactive devices, plasma sources, arc welders, x-ray instruments, intense pulsed sources, or other similar sources of high energy fields whose emissions are not within the normal range expected under the EU EMC Directive.
  22. Ionising Radiation: Please note that this product is not designed to provide protection from ionising radiation. Any customer using this product in such an application should provide their own protection.
  23. This product is a precision scientific instrument containing fragile components. Always handle it with care.
  24. Do not wet or spill liquids on the product, and do not store or place liquids on the product.
  25. If spillage occurs on the product, switch off power immediately, and wipe off with a dry, lint-free cloth.
  26. If any ingress of liquids has occurred or is suspected, unplug the mains cables and do not use. Contact customer support.
  27. See "[General Cleaning & Decontamination Information](#)" on page 131.

- 
28. Do not expose the product to open flames.
  29. Do not allow objects to fall on the product.



---

## 1.1 Label Symbols

	EU CE Mark by which we indicate that this product meets the requirements all the relevant EU Product Directives that require this mark, including the Low Voltage Directive for safety (as this product is manufactured in Northern Ireland, it does not require the UKCA Mark)
 	EU WEEE (Waste Electrical and Electronic Equipment) Mark which indicates that this should not be disposed of in domestic waste but at a suitable recycling site
	China EPUP (Environmental Protection Use Period) Mark that indicates that this product is expected to last for 20 years approximately before ending-up in the waste and recycling system
	D.C. voltage symbol

---

## 1.2 Unpacking Information

Carefully unpack the unit and retain the packaging materials to transport or return equipment if required:

- If the equipment appears damaged in any way, return it to sales outlet in its original packaging.
- No responsibility for damage arising from the use of non-approved packaging will be accepted.
- Ensure all items and accessories specified at the time of ordering and as detailed on the packing list are present: if any items are missing, please contact your sales representative.

---

## 1.3 Revision History

Version	Released	Description
1.0	Monday, December 12, 2022	Initial release.



---

## 1.4 Updates to the Manual

Changes are periodically made to the product, and these will be incorporated into new editions of the manual. Please check for new releases of the manual at: [andor.oxinst.com/downloads](https://andor.oxinst.com/downloads). If you find an issue in this manual, please contact your [customer support representative](#) with a description of the issue.

---

## Section 2 - Introduction

Thank you for choosing the ZL41 Cell Scientific CMOS (sCMOS) camera. You are now in possession of a revolutionary new sCMOS camera, a breakthrough technology based on the next-generation CMOS image sensor (CIS) design and fabrication techniques. The camera offers two image sensors of 5.5 Megapixels (ZL41 Cell 5.5) and 4.2 Megapixels (ZL41 Cell 4.2). It is available in both air cooled, and water cooled forms and with Camera Link and USB 3.0 connection options.



**Figure 1: ZL41 Cell sCMOS Camera**

The ZL41 Cell sCMOS camera offers:

- Extremely low noise
- Rapid frame rates
- Wide dynamic range
- High quantum efficiency (QE)
- High resolution
- Large field of view

This manual contains useful information and advice to ensure you get the optimum performance from your new system. If you have any questions regarding your ZL41 Cell, camera please feel free to contact Andor directly, or via your local representative or supplier.

---

## 2.1 Technical Support

If you have any questions regarding the use of this equipment, please contact the representative from whom your system was purchased, or:

### Europe

Andor Technology  
7 Millennium Way  
Springvale Business Park  
Belfast  
BT12 7AL  
Northern Ireland  
Tel. +44 (0) 28 9023 7126  
Fax. +44 (0) 28 9031 0792

### USA

Andor Technology  
300 Baker Avenue  
Suite # 150  
Concord  
MA 01742  
USA  
Tel. +1 (860) 290-9211  
Fax. +1 (860) 290-9566

### Asia-Pacific

Andor Technology (Japan)  
5F IS Building  
3-32-42 Higashi-Shinagawa  
Tokyo 140-0002  
Japan  
Tel: +81 (0)-3-6732-8968  
Fax: +81 (0)-3-6732-8939

### China

Andor Technology  
Unit 1, Building A,  
66 Zhufang Rd, Haidian Dist.  
Beijing 100085  
China  
Tel: +86 (0)10 8271 9066  
Fax. +86(0)10 8271 9055

The latest contact details for your local representative can be found on our website [andor.oxinst.com/support](https://www.andor.oxinst.com/support)

---

## 2.2 Copyright and Protective Notices

The copyright in this document and the associated drawings are the property of Andor Technology Ltd. and all rights are reserved. This document and the associated drawings are issued on condition that they are not copied, reprinted or reproduced, nor their contents disclosed.

The publication of information in this documentation does not imply freedom from any patent or proprietary right of Andor Technology Ltd. or any third party.

---

## 2.3 Disclaimer

THE INFORMATION CONTAINED HEREIN IS PROVIDED "AS IS" WITHOUT WARRANTY, CONDITION OR REPRESENTATION OF ANY KIND, EITHER EXPRESS, IMPLIED, STATUTORY OR OTHERWISE, INCLUDING BUT NOT LIMITED TO, ANY WARRANTY OF MERCHANTABILITY, NON-INFRINGEMENT OR FITNESS FOR A PARTICULAR PURPOSE.

IN NO EVENT SHALL ANDOR BE LIABLE FOR ANY LOSS OR DAMAGE, WHETHER DIRECT, INDIRECT, SPECIAL, INCIDENTAL, CONSEQUENTIAL OR OTHERWISE HOWSOEVER CAUSED WHETHER ARISING IN CONTRACT TORT OR OTHERWISE, ARISING OUT OF OR IN CONNECTION WITH THE USE OF THE INFORMATION PROVIDED HEREIN.

PLEASE NOTE, AI TRANSLATIONS OF THIS USER MANUAL MAY RESULT IN INCORRECT INFORMATION. IN THE EVENT OF A CONFLICT WITH A FOREIGN LANGUAGE TRANSLATION, ANDOR'S ENGLISH TRANSLATION WILL PREVAIL.

---

## 2.4 Trademarks and Patent Information

Andor, ZL41 Cell and the Andor logo are trademarks of Andor Technology Ltd. Andor Technology Ltd. is an Oxford Instruments company. All other marks are property of their owners.

### **Manufacturers Information**



Andor Technology Ltd., Belfast, BT12 7AL, UK.

## 2.5 Supplied Components

The standard components supplied with the ZL41 Cell are shown below:

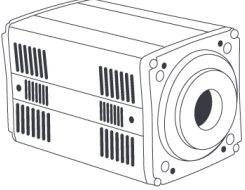
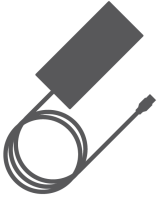
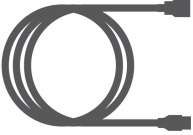
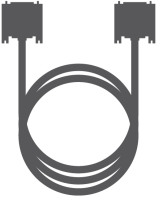
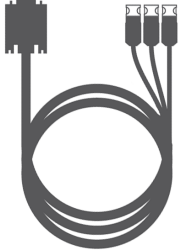
**Table 1: Supplied components.**

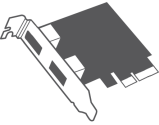
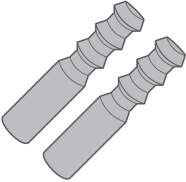
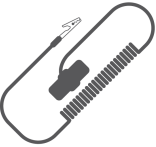
Image	Description	Quantity
	ZL41 Cell 5.5 or ZL41 Cell 4.2 sCMOS Camera with Integral Lens Mount Adaptor (C, CS or F-mount: as selected at time of ordering)	1
	Power supply unit (PS12)	1
	Country specific power cable	1
	Camera to PC Interface cable(s) USB 3.0 10-tap	1 x 3 m 2 x 3 m
	Multi I/O timing cable	1 x 3 m

	Description	Quantity
	PCIe frame grabber card	1
	Coolant hose inserts (for water cooled models only)	2
	Anti-static strap	1
	Quick start guide	1
	Hex key set (1.5 mm)	1



---

## 2.6 Camera Model Options

There are a number of models of ZL41 Cell camera based off of a common architecture and shared design. The differences for each model can be identified from the product codes and descriptions outlined below:

**Table 2:Model options.**

Description	Code
ZL41 Cell 4.2 PLUS, 4.2 Megapixel, Rolling shutter, 100 fps, Camera Link 10-tap	<b>ZYLA-4.2P-CL10-C</b>
ZL41 Cell 4.2 PLUS, 4.2 Megapixel, Rolling shutter, 53 fps, USB 3.0	<b>ZYLA-4.2P-USB3-C</b>
ZL41 Cell 5.5, 5.5 Megapixel, Rolling and Global shutter, 40 fps, USB 3.0	<b>ZYLA-5.5-USB3-C</b>

---

## 2.7 Optional Components

There are a range of optional and additional accessories available for ZL41 Cell including:

**Table 3:Optional components.**

Description	Order Code
SRRF-Stream+ real time super resolution for ZL41 Cell 4.2	<b>SRRF-Stream-Zyla-4P</b>
CS-mount adapter	<b>ACC-MEC-05609</b>
F-mount adapter	<b>ACM-05574</b>
Auto extension tubes (set of 3) for C-mount	<b>OA-ECMT</b>
Auto extension tubes (set of 3) for Nikon F	<b>OA-ENAF</b>
Re-circulator for enhanced cooling performance	<b>XW-RECR</b>
Oasis 160 Ultra compact chiller unit	<b>ACC-XW-CHIL-160</b>
5 meter cable for use with Axion frame grabber for Camera Link 10-tap models. (2 required)	<b>ACC-ASE-13532</b>
3 meter 7-way Multi I/O timing cable, offering Fire, External Trigger, Shutter and Arm.	<b>ACC-ACZ-05612</b>

Please see the product specifications or contact Andor or your nearest Andor representative for further information.

Longer lengths of USB 3.0 cable are available from other suppliers such as Stemmer/CEI.

---

## Section 3 - Product Overview

This section provides an overview of the main features of the ZL41 Cell.

ZL41 Cell 4.2 PLUS and 5.5 are available as water cooled or air cooled models. ZL41 Cell 4.2 PLUS comes equipped with a 4.2 Megapixel sensor and rolling shutter as standard. Whereas ZL41 Cell 5.5 has a 5.5 Megapixel sensor, with both rolling and global shutter options. Both models can be fitted with USB 3.0 or CameraLink connectivity. Please see your individual purchase order for details on your specific model.



**Figure 2:ZL41 Cell sCMOS Camera**

---

## 3.1 Rear Panel

The rear panel of both USB 3.0 and Cameralink models is shown below.



**Figure 3:ZL41 Cell Back Plate Connections (Left) Cameralink versions (Right) USB 3.0 version**

1. I/O 15-Way D Type Connector
2. 12V DC Power Connector, see ["Power Supply Information" on page 146](#) for more information.
3. CL1 connector, this is the connection for the Camera Link version of the ZL41 Cell camera.
4. CL2 connector, this connection is required for the 10-tap (double cable) Camera Link version of the ZL41 Cell 5.5 and ZL41 Cell 4.2 camera .
5. On/Off Switch
6. USB 3.0 Connector, this is the connection for the USB 3.0 version of the ZL41 Cell camera. It is not present on the Camera Link versions.

### 3.1.1 Multi I/O Timing Cable Pin Outs

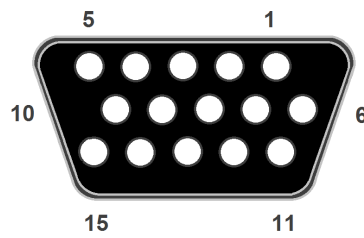

**Table 4: Multi I/O Timing Cable Pinouts 15-way D type connector**

1	ARM	9	Reserved
2	AUX_OUT_1	10	Reserved
3	FIRE n	11	Reserved
4	FIRE	12	Reserved
5	AUX_OUT_2	13	Reserved
6	Ground	14	Reserved
7	External Trigger	15	Reserved
8	Spare (I)		

- **External Trigger and Spare input** are 5 V TTL input. By default they trigger on a rising edge.
- **Fire, Fire n, Arm, AUX\_OUT\_1 and AUX\_OUT\_2** outputs are all TTL timing outputs (please also refer to "[Impedance Information](#)" on page 23 for information on impedance matching)
- **TTL I/O** can be individually inverted via software (e.g. Solis or SDK)
- **Pins 9 to 15** are reserved and should not be used.
- **AUX\_OUT\_1** supplies the 'FIRE ALL' output by default. This is the logical AND of the FIRE pulses associated with Row #1 and Row #n (the last row read out in the image frame). Therefore the FIRE ALL pulse represents the time within a frame when all rows on the sensor are simultaneously exposing.
- **AUX\_OUT\_1** is also configurable as FIRE, FIRE n and FIRE ANY. The FIRE ANY pulse represents the time within a frame when any row of the image frame is exposing. Refer to "[Trigger Modes](#)" on page 76 for the behaviour of these signals and to the SDK3 manual for configuring the AUX\_OUT\_1 output.

---

Note

This configurable output is only available on cameras with FPGA version numbers  $\geq$  20120802 and Solis versions  $\geq$  4.22.30001.0 (SDK users require version  $\geq$  3.5.30001.0).

- **AUX\_OUT\_2** output is reserved for future use.
- **I/O Timing Interface cable** (Andor part number ACC-ACZ-05612) gives access to all of the above I/O functions (excluding Ground and Reserved).

### 3.1.2 Impedance Information

#### Ext Trigger & Spare Inputs

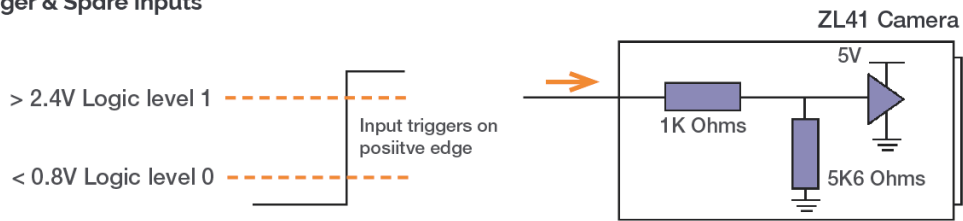

#### Arm, Fire, Fire n and AUX\_OUT Outputs

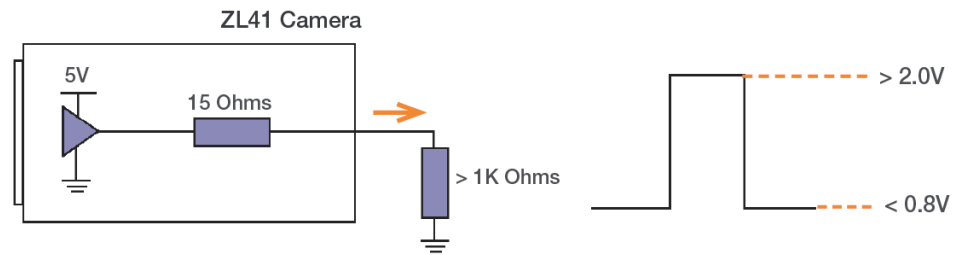

Figure 4: ZL41 Cell connection impedance information

---

## 3.2 Cooling Hose Connectors

There are two connectors to allow connection of Liquid Cooled ZL41 Cell models to a water cooler or re-circulator. Hose inserts are provided to enable connection to coolant hoses. On ZL41 the cooling hose connectors are located on the side of the camera, similar to Zyla.

Please refer to "[Connecting a Cooling System](#)" on page 34 for details of connector and hose type compatibility and for connection and disconnection information.



---

### 3.3 Camera based Super Resolution (SRRF-Stream+)

Certain Andor cameras including ZL41 Cell have been developed to enable super-resolution imaging to be achieved using a normal microscope. This technology is called SRRF-Stream+. It is a cell friendly and easy to use approach to achieving sub-diffraction limited resolutions. It is based on the SRRF (Super Resolution Radial Fluctuations) method of Gustafsson et al (2016). The benefits of this camera and software method are:

- Can use normal fluorophores and labelling protocols
- Use low illumination intensities e.g. LED illumination
- No need for specialised microscope: an existing microscope may be used with a suitable graphics card and compatible Andor camera

This makes it not only a cell-friendly way to perform super resolution imaging, but also makes high resolution imaging accessible a much wider range of researchers. There is little change to the existing imaging workflow. Resolutions down to ~100 nm may be obtained by this method depending on the specific microscope and labelling.

For full information on camera based super-based super resolution and camera compatibility please refer to [SRRF-Stream+ Super Resolution](#).

**If you have purchased a SRRF-Stream+ license for your camera please see our support documentation to get started:**

- [SRRF-Stream+ Quick Start Guide](#)
- [SRRF-Stream+ User Guide](#)

---

## Section 4 - Installation

### Caution

Prior to commencing installation, the user should refer to the safety and warning information and unpacking instructions at the beginning of this manual.

Due care must be taken when lifting the camera. Ensure that the mounting and connected assembly is secure and able to support the weight of the camera.

Power cabling and control cables should be routed to prevent accidents, damage and accidental unplugging while avoiding bend radii of less than 30 mm.

Temperature and humidity must meet the specifications defined in technical specifications.

---

## 4.1 Transport and Storage

- The camera is packed in normal transport packaging for shipping.
- Allow the product to reach the ambient temperature after unpacking- especially if moving from a colder environment to a warm environment as this may lead to condensation.

### Storage

- Temperature and humidity must meet the specifications defined in ["Environmental Specifications" on page 144](#).
- If it is to be stored after use at a temperature below the coolant freezing point, ensure that all liquid coolant has been expelled from the camera.

---

### 4.1.1 Using Lens Mount Adaptors

The ZL41 Cell has a T-mount thread as standard. There are 3 standard lens mount adaptors available that can be specified at the time of ordering, enabling the Zyla to suit standard mounting options. These are as follows:

- C-mount
- CS-mount
- F-mount

The ZL41 Cell is supplied with the selected lens mount adaptor locked into a nominal position of 1 mm from the top surface of the ZL41 Cell faceplate. Adaptors can be removed, inserted and adjusted (for focus optimization) as required

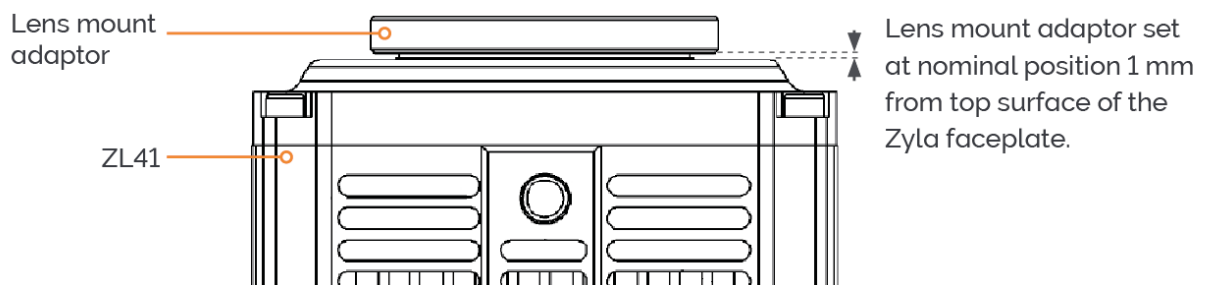

**Figure 5: Lens mount adaptor fitted to ZL41 Cell (In this example a CS-mount adaptor is shown).**

---

## 4.1.2 C-mount or CS-Mount Adaptor

The C-mount adaptor can be adjusted as follows:

1. Loosen the 2 locking screws located in the front face of the adaptor if required using supplied 1.5 mm Allen key.

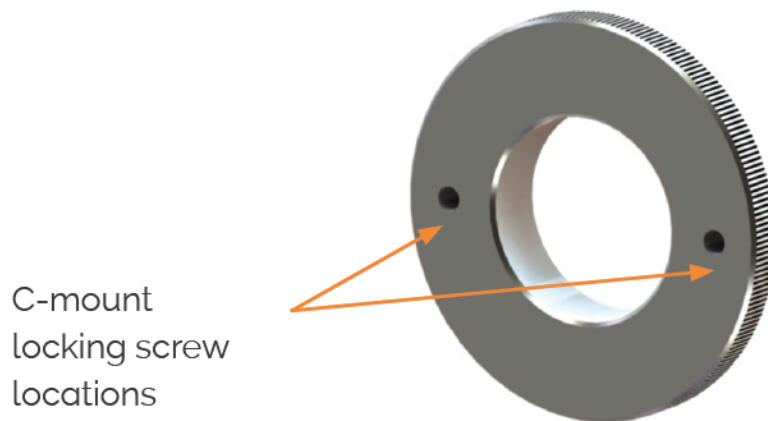

Figure 6:C-mount adaptor

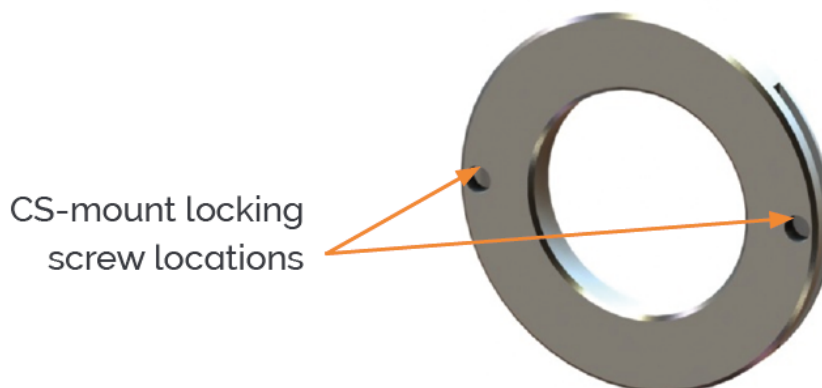

Figure 7:CS-mount adaptor

2. Manually screw the C-mount into position until the desired focus is achieved. It must not be screwed the entire way into the faceplate.
3. Lock the C-mount into position using the 2 locking screws and 1.5 mm hex key.

Note
Maximum torque applied must not exceed: 0.6 Nm

---

### 4.1.3 F-mount Adaptor

The F-mount should be screwed into the camera faceplate by hand.



**Figure 8:F-mount adaptor**

1. Manually screw the F-mount adaptor until the desired focal position is achieved.
2. Manually tighten the collar down to the camera faceplate to lock the mount in position.

---

#### 4.1.4 Mounting the Camera using the Mounting Flange

The camera mounting face features 4 off M4x0.7 tapped holes x7.0[0.275] deep. These can be used to secure the camera to an appropriate mounting as an alternative to using the lens mounts.

**Caution**

**The weight of the camera is approx. 1 kg ensure that the mounting and the system it is connected to provides adequate support.**

---

## 4.2 Cooling

### Integral Thermal Protection

Care should be taken to ensure that the camera does not overheat, as this can cause system failure. Overheating may occur if either of the following situations arises:

#### Air-cooled Models

- The air vents on the sides of the head are accidentally blocked
- The ambient air temperature is more than 30°C (ZL41 Cell 5.5), or 27°C (ZL41 Cell 4.2)

To protect the camera from overheating, a thermal switch has been attached to the heat sink. If the temperature of the heat sink rises above predefined limit then the current supply to the cooler will cut out and a buzzer will sound. To reset this, it is necessary to exit the software and switch off the camera, correct the issue, let the system cool then restart the camera and software.

#### Water-cooled Models

- The coolant system is not operating correctly

To protect the camera from overheating, a thermal switch has been attached to the heat sink. If the temperature of the heat rises above predefined limit then a buzzer will sound. To reset this, it is necessary to exit the software and switch off the camera, correct the issue, let the system cool then restart the camera and software.

#### TE Cooling (Air-Cooled Models)

The ZL41 Cell sCMOS sensor is cooled using a thermoelectric (TE) cooler. TE coolers are small, electrically powered devices with no moving parts, making them reliable and convenient. A TE cooler is actually a heat pump, i.e. it achieves a temperature difference by transferring heat from its 'cold side' (the CMOS-chip) to its 'hot side' (the built-in heat sink). Therefore the minimum absolute operating temperature of the ZL41 Cell sensor depends on the temperature of the heat sink. The maximum temperature difference that a TE device can attain is dependent on the following factors:



- 
- Heat load created by the ZL41 Cell sensor (dependant on pixel readout speed)
  - Number of cooling stages of the TE cooler
  - Operating current
  - Hot side temperature of thermoelectric cooler

Even with a fan, a heat sink typically needs to be at least 10°C hotter than the air (room) temperature to transfer heat efficiently to the surrounding air. Therefore during normal operation the temperature of the heatsink within the camera head will be warmer than the ambient (room) temperature.

### **TE Cooling (Water Cooled Models)**

For water cooled models the dissipation of heat from the TE cooler is achieved by circulating coolant liquid through the heat sink. The high specific heat capacity of water provides efficient heat dissipation, allowing the sensor to be operated at -10°C. Benefits of water cooling include:

1. Reduced vibration as there is no cooling fan required, which may be useful for ultra-sensitive measurements and
2. Improved dark current.

---

## 4.3 Connecting a Cooling System

The standard camera uses air cooling to cool the sensor to 0°C. A model with liquid cooling can be used for deeper cooling to -10°C.

### Important Considerations when using Liquid Cooling Systems

#### Caution

**Before attempting to insert or remove the coolant hose connections, ensure that all coolant has been drained from the hoses and integral coolant channel within the camera head.**

**Care must be taken to avoid permanent damage to the camera system resulting from either leakage of coolant during connection/removal of hoses or spillage of any residual coolant contained within the camera head once the hoses have been removed.**

**Always ensure that the temperature of the liquid coolant circulated through the camera head is above the dew point of the camera ambient temperature and humidity conditions. Refer to "[Dew Point Graph](#)" on page 150 for guidance.**

**Use of coolant at or below the dew point can result in permanent damage to the camera head, due to formation of condensation on internal components.**

**Never use damaged, split or worn hoses as leaks may find their way to the mains electricity supply and create a hazard.**

**The water cooling system of the camera is rated for operation up to 2 bar (200 kPa). If your water supply exceeds this value, then an overpressure safety device or regulator must be fitted to restrict the water pressure to less than or equal to this rating.**

**In the event that replacement hose inserts/barbs are required, please place an order using the correct product code.**

**Always remove residual coolant from the camera head if the camera is to be stored after operation especially if the storage conditions are below the freezing point of the coolant.**

There are two connectors to allow connection of Water Cooled ZL41 Cell models to a water cooler or re-circulator. Hose inserts are provided to enable connection to coolant hoses. See "[Cooling Hose Connectors](#)" on page 24 for connector positions.

### Hose Inserts

Hose inserts are provided to enable connection to coolant hoses.

- **Coolant Hose Inserts:** Two barbed coolant hose inserts (replacement part code 6MM-HOSE-BARBS) are supplied as standard, suitable for connection to

---

6 mm [0.25"] internal diameter soft PVC tubing / hose.

- **Recommended tubing:** 10 mm [0.4"] outside diameter, i.e. a wall thickness of 2 mm [0.08"]. Alternative hose dimensions and materials should be thoroughly tested to ensure a leak tight seal is achieved with the barbed inserts.

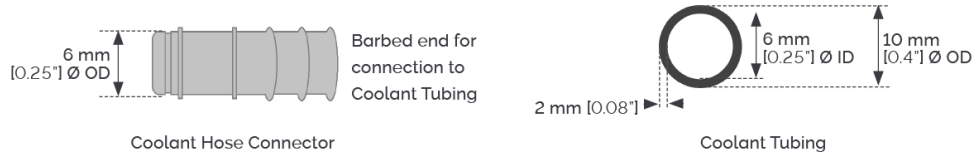

---

## 4.4 Coolant Recommendations

- **Coolant temperature:** Refer to the temperatures specified in Technical Specifications. Note that cooling performance may be affected by distance between camera head and cooler.
- **Recommended coolant:** water or water/glycol mix depending on the ambient environmental temperature during operation.

De-ionized water (without additives) may be used as the coolant. Some mains supply water is heavily mineralized (i.e. "Hard") which could cause deposits in the water circuit inside the camera. This can reduce the flow-rate and cooling efficiency.

### Caution

**The liquid cooling system of the camera is rated to 2 bar (200 kPa). If your water supply exceeds this value, then an overpressure safety device or regulator must be fitted to restrict the water pressure to less than or equal to this rating.**

---

### 4.4.1 Connecting the Coolant Hoses

1. Press the hose connector into the connection on the camera head, ensure it clicks into place and repeat for the second hose.



2. Confirm the hoses are connected securely by applying pressure on the top front of the camera body and pulling backwards on the hoses.



3. The coolant hoses are now connected.

---

## 4.4.2 Disconnecting the Coolant Hoses

1. Press the latch on the camera hose connection away from the hose.
2. Hold the latch in and pull the hose backwards.
3. The hose should release from the camera connection with little resistance.

### Note

**If the hose does not release, ensure that the latch on the camera connection is pressed in fully.**

---

## 4.5 Connecting the Camera to the PC

The camera connects to a PC via USB or CameraLink that provides a standard, robust and high-speed connection with the control PC. It is recommended to use the supplied PCIe card as this will ensure consistent performance. Other ports on the PC may share bandwidth with other devices and peripheral components. This may cause reduced, or inconsistent performance.

## 4.5.1 Installing the Camera Framegrabber Card

### Note

Camera operation with PCIe cards not supplied by Andor cannot be guaranteed.

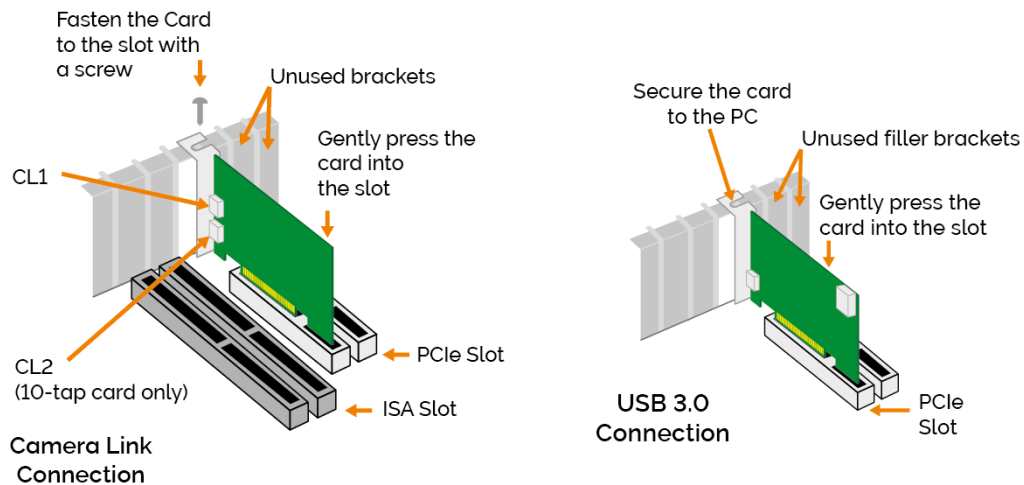

**Figure 9: Installing the FrameGrabber PCIe card (Left) Camera Link versions and (Right) for USB 3.0.**

1. Unplug all cables from the rear of the computer
2. Open the PC enclosure to gain access to the expansion slots.
3. Locate a suitable PCIe slot:
  - **10-tap version:** Framegrabber card operates in x8 or greater (i.e. x16 and x8 slots) ONLY.
  - **USB 3.0 version:** Framegrabber card operates in x4 or greater (i.e. x16, x8 or x4 slots).

If you are unsure which slot is correct, please consult the PC user manual.

4. Remove the filler bracket corresponding to the slot you intend to use.
5. Remove the controller card carefully from its protective ESD packaging and insert the card connector fully into the expansion slot.
6. Ensure the card's mounting bracket is flush with any other mounting or filler brackets to either side of it, then secure the controller card in place.



- 
7. Replace the computer cover and secure with mounting screws if applicable.
  8. Reconnect any accessories you were using previously.

---

## 4.5.2 Connecting the Camera to the PCIe Card

### 4.5.2.1 Connecting via USB

Connect the USB cable from the camera to the appropriate PCIe card on the control PC.

### 4.5.2.2 Connecting via CameraLink

Connect the CameraLink cable from the camera to the appropriate PCIe card on the control PC. Camera Link cables are labeled to assist with correct installation.

### 4.5.2.3 Connecting the Camera to the Power Supply

Connect the mains power cable between the camera power input (12 V DC) and the 12 V DC power supply unit. Route cables carefully so they do not pose a tripping hazard or at risk of being unplugged. Avoid tight bends or strain at the connections. Connect the power supply unit to the mains power supply.

---

## 4.6 Installing Software and Drivers

---

## 4.6.1 Minimum Computer Requirements

- 2.68 GHz Quad Core + 4 GB RAM
- Hard Drive:
  - Minimum 850 MB/s continuous write for ZL41 Cell CL 10-tap models
  - Minimum 450 MB/s continuous write for ZL41 Cell USB 3.0 models
- PCI Express x8 or greater for ZL41 Cell CL 10-tap models
- PCI Express x4 or greater for ZL41 Cell USB 3.0
- Windows (8.1 and 10) or Linux

---

## 4.6.2 Installing Software or Drivers

The same instructions cover the installation procedure for Andor's Solis software or Andor's SDK, which is used in conjunction with third party software. If you are planning to run your camera through a third party interface you will require the Andor Drivers, called Software Development Kit (SDK). For sCMOS cameras, SDK3 is required whereas, SDK2 is required for CCD and EMCCD cameras. If purchased please visit [andor.oxinst.com/downloads](https://www.andor.oxinst.com/downloads) to request a software or driver download.

Note
<b>You must have administrator access on your PC to perform this installation</b>

1. Terminate & exit any applications which are running on the PC.
2. Insert or run the provided or downloaded copy of Andor Solis or SDK. The InstallShield Wizard should now start. If it does not start automatically, run the file Solis setup.exe file.
3. Select appropriate location for installation of software and drivers on your computer / network.
4. If prompted, select ZL41 Cell.
5. Continue installation and restart your computer - when prompted - to successfully complete the installation.
6. The camera is now ready to be connected to a PC / laptop and powered on.

---

### 4.6.3 New Hardware Wizard

When the ZL41 Cell camera is connected to a PC for the first time, the New Hardware Wizard screen will appear.

1. Select the 'No, not this time only' option then click Next>.
2. Select the 'Install from a list or specified location (Advanced)' option then click Next>.
3. Navigate to the directory where the Andor Solis software was installed to on the PC, then click Next> so that the Installation Wizard can start.
4. Click the Finish button to complete the installation.

**Note**

**If the camera is connected to a different USB port, steps 1 – 4 will have to be repeated on the first connection only.**

5. A system message will appear to indicate that the device has been successfully installed.

**Note**

**You can check that the camera is correctly recognized and installed by opening the Device Manager (Devices and printers) in Windows, Control Panel. The camera will show under the Devices list.**

---

#### 4.6.4 Checking & Setting BIOS options (for PCs not supplied by Andor)

Enter the BIOS menu when starting PC. For Dell workstations, press F12 at start-up and select System Setup in the One Time Boot Menu. For Dell workstations 3 options in the Performance menu of the BIOS need to be checked/set:

- C-States Control – Disable C-States
- Intel Speed-step – Disable Speed-step
- Memory Node Interleaving – Set from NUMA to SMP. Note: This option is only available on larger workstations with 2 physical processors and may have a different name- ensure that NUMA is disabled

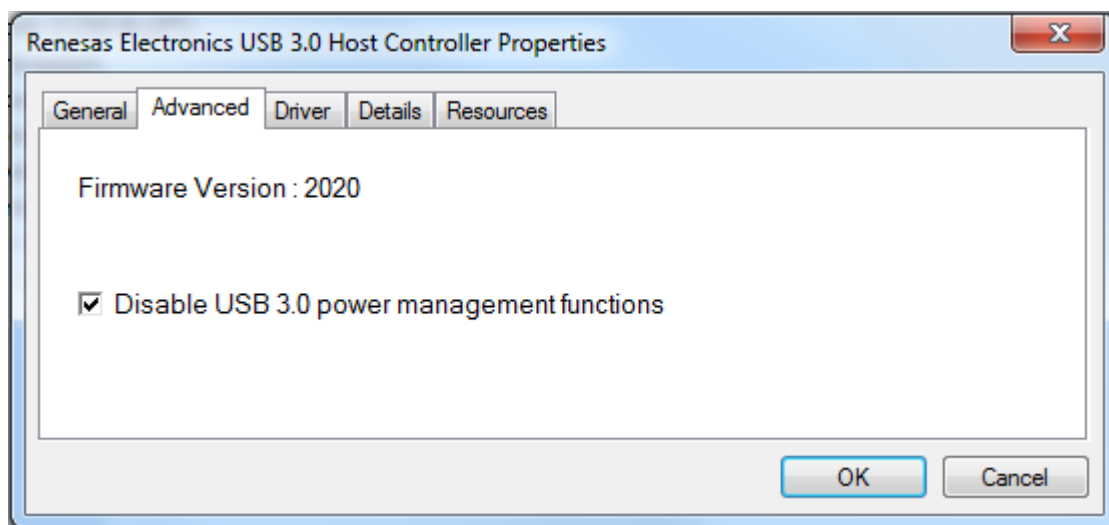

---

## Section 5 - Operation

### Caution

**IF THE EQUIPMENT IS USED IN A MANNER NOT SPECIFIED BY ANDOR OR ITS DISTRIBUTORS, THE PROTECTION PROVIDED BY THE EQUIPMENT MAY BE IMPAIRED.**

**PLEASE READ THE USER GUIDES SUPPLIED WITH YOUR SYSTEM COMPONENTS AND CAMERA CONTROL SOFTWARE PRIOR TO USE.**



---

## 5.1 Emergency Mains Disconnection

In case of emergency, the disconnecting point of the equipment is the mains power cord connected to the external power supply, or the mains socket switch.

**WARNING**

**SWITCH OFF THE POWER AT THE MAINS SOCKET AND REMOVE THE MAINS LEAD FROM THE EXTERNAL POWER SUPPLY**

---

## 5.2 Power Up Sequence

1. Ensure that the camera is powered on at the mains power supply. (There is an ON/OFF switch on the backplate of the camera).
2. Ensure that the USB or Camera Link cable is connected between the camera and the PC.
3. Switch on the camera using the ON/OFF switch at the rear panel of the camera.
4. Start up the PC.
5. Launch your camera control software e.g. Solis, Fusion or SDK3.
6. The camera will now start up under control of the software.
7. Refer to your software manual for set-up and image acquisition information.

---

## 5.3 Power Down Sequence

1. Exit the camera control software.
2. Switch the camera off using the switch on the rear panel .
3. If not using the camera for some time, disconnect from the mains power socket.

---

## 5.4 Using the Camera

Once set-up the camera is controlled through the camera control software. Please refer to the information supplied with the camera control software (available separately) for further details e.g. Andor Solis or SDK3. Some important features and concepts are outlined in the following sections.

## 5.5 sCMOS Structure and Operation

sCMOS technology has been developed specifically to overcome many of the limitations that have marred other scientific detector technologies, resulting in an imaging detector that provides exceptional performance for many applications.

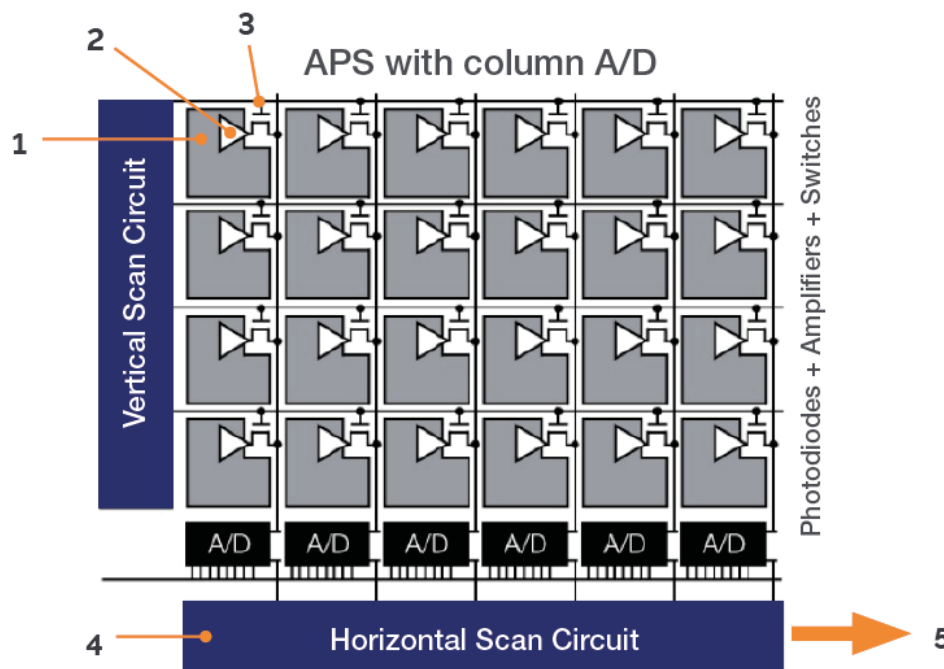

As illustrated above, the CMOS sensor is an “Active Pixel Sensor” (APS) whereby each pixel has its own integral amplifier and the sequence of operation is as follows:

1. Light hits sensor and generates charge (electrons).
2. The photo-generated charge is converted to an analog voltage inside each pixel amplifier
3. Pixel voltage is transferred to the column bus via a row select signal
4. The analog voltage is then converted to a digital signal via columns of A/D (analog to digital) converters.
5. The final digitized signals are then read out sequentially at a pixel readout speed of up to 280 MHz for the ZL41 Cell 5.5 and 270 MHz for the ZL41 Cell 4.2 (in x2 halves).

---

## Notes

The diagram, above is representative - the light sensitive area is contiguous as the photodiodes for each pixel are buried within the sensor. Each pixel also has a microlens to maximize sensitivity to light.

For Rolling Shutter mode operation, pixels in each row are exposed and the charge converted to a voltage simultaneously before being digitized then read out sequentially.

For Global Shutter mode, each pixel in the sensor begins an exposure simultaneously and then ends this exposure simultaneously.

---

## 5.6 Dual Amplifier Dynamic Range

The Dual Amplifier architecture of the sCMOS sensor in ZL41 Cell eliminates the need to choose between low noise or high capacity, in that signal can be sampled simultaneously by both high gain and low gain amplifiers. As such, the lowest noise of the sensor can be harnessed alongside the maximum well depth, affording the widest possible dynamic range. Traditionally, scientific sensors including CCD, EMCCD, ICCD and CMOS, demand that the user must select 'upfront' between high or low amplifier gain (i.e. sensitivity) settings, depending on whether they want to optimise for low noise or maximum well depth. Since the true dynamic range of a sensor is determined by the ratio of well depth divided by the noise floor detection limit, then choosing either high or low gain settings will restrict dynamic range by limiting the effective well depth or noise floor, respectively.

For example, consider a large pixel CCD, with 16-bit Analog to Digital Converter (ADC), offering a full well depth of 150,000 e<sup>-</sup> and lowest read noise floor of 3 e<sup>-</sup>. The gain sensitivity required to give lowest noise is 1 e<sup>-</sup>/ADU (or 'count') and the gain sensitivity required to harness the full well depth is 2.3 e<sup>-</sup>/ADU, but with a higher read noise of 5 e<sup>-</sup>. Therefore, it does not automatically follow that the available dynamic range of this sensor is given by  $150,000/3 = 50,000:1$ . This is because the high sensitivity gain of 1 e<sup>-</sup>/ADU that is used to reach 3 e<sup>-</sup> noise means that the 16-bit ADC will top out at 65,536 e<sup>-</sup>, well short of the 150,000 e<sup>-</sup> available from the pixel. Therefore, the actual dynamic range available in 'low noise mode' is  $65,536/3 = 21,843:1$ . Conversely, the lower sensitivity gain setting means that the ADC will top out at ~ 150,000 e<sup>-</sup>, but the higher read noise of 5 e<sup>-</sup> will still limit the dynamic range to  $150,000/5 = 30,000:1$  in this 'high well depth mode'. The sCMOS sensor offers a unique dual amplifier architecture, meaning that signal from each pixel can be sampled simultaneously by both high and low gain amplifiers. The sensor also features a split readout scheme in which the top and bottom halves of the sensor are read out independently. Each column within each half of the sensor is equipped with dual column level amplifiers and dual analog-to-digital converters, represented by the block diagram below:

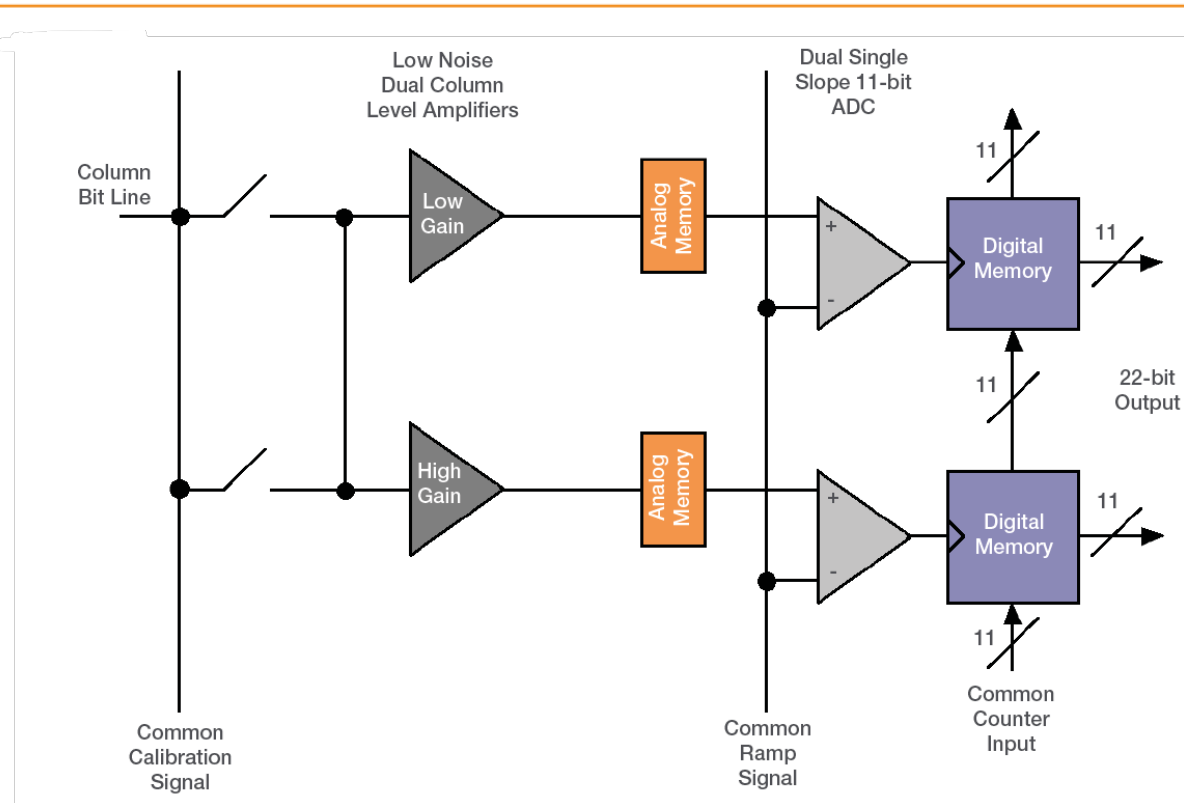

**Figure 10: Amplifiers and ADC of the sCMOS Sensor**

The dual column level amplifier/ADC pairs have independent gain settings, and the final image ("High contrast image of fixed labeled cell. Intensity line profile through single row demonstrates pixel regions that were sampled by high gain (low noise) and low gain (high capacity) amplifiers." on page 58) is reconstructed by combining pixel readings from both the high gain and low gain readout channels to achieve a wide intra-scene dynamic range, uniquely so considering the relatively small 6.5  $\mu\text{m}$  pixel pitch.

The method of combining signals from two 11-bit ADCs can be divided into four basic steps.

1. At the end of the analog chain the "Signal" voltage is applied to two independent amplifiers: the high gain amplifier and the low gain amplifier. This results in two separate digital data streams from the sensor
2. The camera selects which data stream to use on a pixel per pixel, frame by frame basis using a threshold method
3. The data is then compensated for DC offset and gain. Again, this is done on a pixel by pixel basis using the compensation data associated with the data



stream. The gain corrects for pixel to pixel relative sensitivity, pixel node amplifier and the high and low amplifier relative gains

4. The pixels are then combined into a single 16-bit image for transfer to the PC

The user maintains the choice of opting to stay with 12-bit single gain channel data if dynamic range is not critical, resulting in smaller file sizes. This in turn offers faster frame rates when continuously spooling through the Camera Link interface and writing to hard disk.

**Table 5: Typical performance of supported gain settings of the ZL41 Cell 5.5 (Jan 2012 onwards)**

Amplifier Gain (Current Andor SDK / Solis description)	Mode	Sensitivity e-/ADU (typical)	Data Range	Effective pixel saturation limit / e-	Spooling File Size (per frame)
12-bit (high well capacity)	GS/RS	7.5	12-bit	30,000	8 Mb
12-bit (low noise)	GS	0.42	12-bit	1,700	8 Mb
12-bit (low noise)	RS	0.28	12-bit	1,100	8 Mb
16-bit (low noise and high well capacity)	GS	0.45	16-bit	30,000	10.5 Mb
16-bit (low noise and high well capacity)	RS	0.45	16-bit	30,000	10.5 Mb

**Table 6: Typical performance of supported gain settings of the ZL41 Cell 4.2**

Amplifier Gain (Current Andor SDK / Solis description)	Mode	Sensitivity e-/ADU (typical)	Data Range	Effective pixel saturation limit / e-	Spooling File Size (per frame)
12-bit (high well capacity)	RS	7.5	12-bit	30,000	6.1 Mb
12-bit (low noise)	RS	0.28	12-bit	1,100	6.1 Mb
16-bit (low noise and high well capacity)	RS	0.45	16-bit	30,000	8.1 Mb

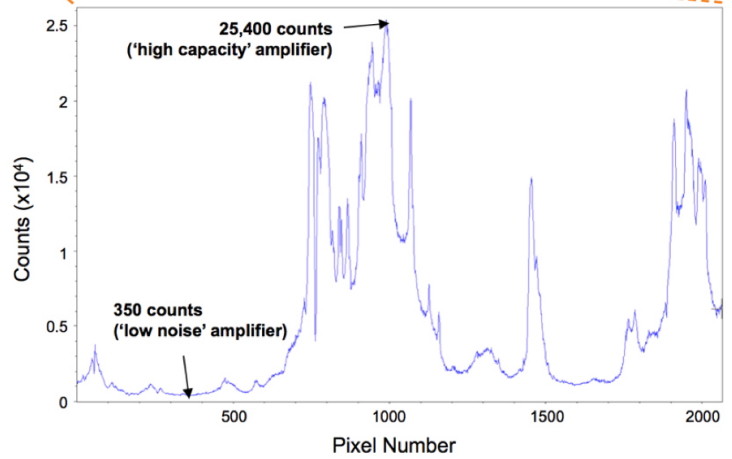
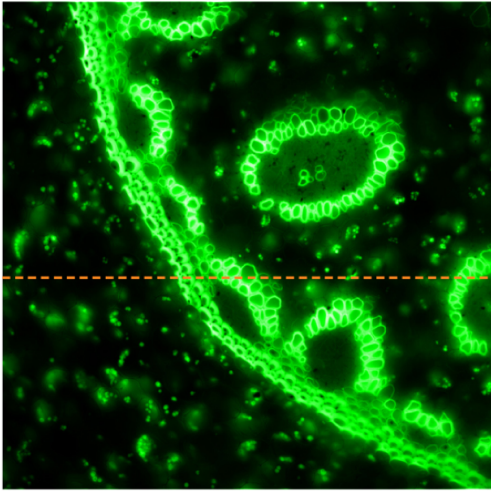

**Figure 11: High contrast image of fixed labeled cell. Intensity line profile through single row demonstrates pixel regions that were sampled by high gain (low noise) and low gain (high capacity) amplifiers.**

---

### 5.6.1 Using ROIs (AOIs)

Region of Interest (ROI) also called Area of Interest (AOI) can be selected so that only a defined region of the sensor is used. When a sub image has been defined, only data from the selected rows will be digitized.

Selecting a sub image increases the frame readout rate and reduces image storage requirements. Examples of sub-image selection and spooling rates are shown in [Sensor Readout Optimisation](#).

It should be noted that for small ROIs (e.g. < 512 x 512 pixels), the achievable frame rate for 3-tap and 10-tap becomes identical. This is due to the fact that the amount of data transmitted across the Camera Link interface for these ROIs is relatively small and the limiting factor becomes the rate at which data can be read off the sensor.

It should also be noted that while ROIs can also be set up for any area of the sensor, those which are vertically centred on the sensor mid line will result in the maximum frame rates.

---

## 5.7 Understanding Read Noise in sCMOS

sCMOS technology boasts an ultra-low read noise floor that significantly exceeds that of even the best CCDs, and at several orders of magnitude faster pixel readout speeds. For those more accustomed to dealing with CCDs, it is useful to gain an understanding of the nature of read noise distribution in CMOS imaging sensors.

CCD architecture is such that the charge from each pixel is transferred through a common readout structure, at least in single output port CCDs, where charge is converted to voltage and amplified prior to digitization in the Analog to Digital Converter (ADC) of the camera. This results in each pixel being subject to the same readout noise. However, CMOS technology differs in that each individual pixel possesses its own readout structure for converting charge to voltage. In the sCMOS sensor, each column possesses dual amplifiers and ADCs at both top and bottom (facilitating the split sensor readout). During readout, voltage information from each pixel is fed directly to the appropriate amplifier/ADC, a row of pixels at a time (see Technical Note on Rolling and Global Shutter modes).

As a consequence of each pixel having its own individual readout structure, the overall readout noise in CMOS sensors is described as a distribution, as exemplified in "Representative histogram showing read noise distribution at fastest readout speed of ZL41 Cell 5.5, 560 MHz (280 MHz x2). The median value of 1.38 e- means 50% pixels have read noise less than 1.38 e- and 50% have greater than 1.38 e-. The line at 6 e- represents a typical read noise value from a well optimized Interline CCD – all pixels in a CCD essentially share the same noise value" on the next page below, which is a representative noise histogram from a ZL41 Cell 5.5 camera at the fastest readout speed of 560 MHz (or 280 MHz x 2 halves). It is standard to describe noise in CMOS technology by citing the median value of the distribution. In the data presented, the median value is 1.38 electron RMS. This means that 50% of pixels have a noise less than 1.38 electrons, and 50% have noise greater than 1.38 electrons. While there will be a small percentage of pixels with noise greater than 2 or 3 electrons, observable as the low level tail towards the higher noise side of the histogram, it must be remembered that a CCD Interline camera reading out at 20 MHz would have 100% of its pixels reading out with read noise typically ranging between 6 and 10 electrons RMS (depending on camera design).

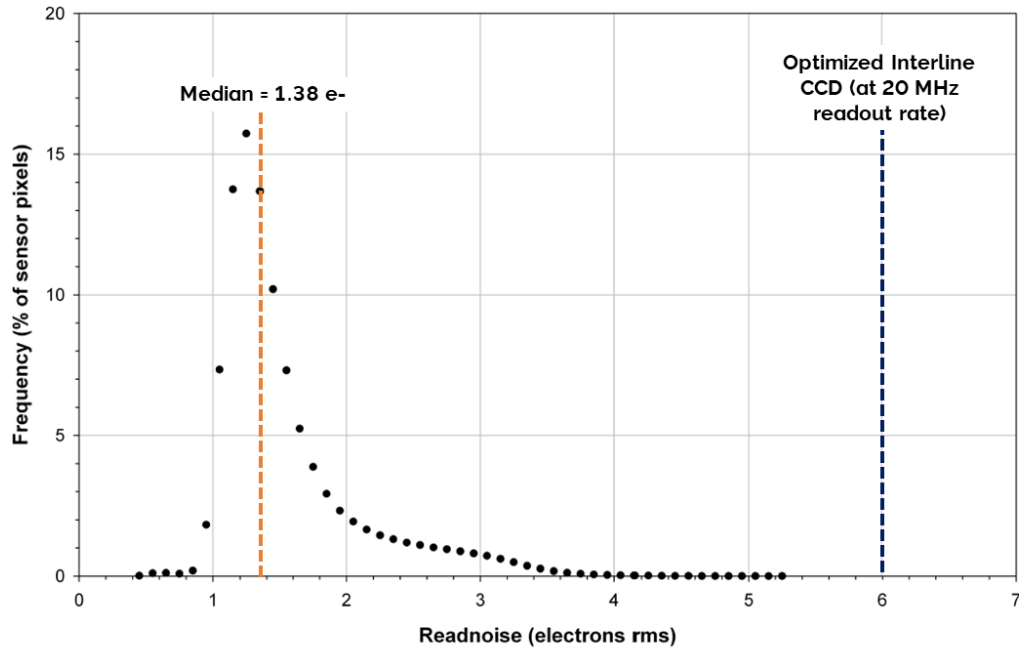

**Figure 12: Representative histogram showing read noise distribution at fastest readout speed of ZL41 Cell 5.5, 560 MHz (280 MHz x2). The median value of 1.38 e- means 50% pixels have read noise less than 1.38 e- and 50% have greater than 1.38 e-. The line at 6 e- represents a typical read noise value from a well optimized Interline CCD – all pixels in a CCD essentially share the same noise value**

---

### 5.7.1 Binning

Binning is a process used for both CCD and sCMOS sensors in which the signal for a number of pixels is combined into a single array with a single signal output. For CCD sensors combining the charge from arrays of pixels e.g. 4 pixels (2x2 binning) into single larger "super-pixels" allows the read noise (the dominant noise source in CCDs) to be reduced since there are less read events. Binning is therefore commonly used for CCD cameras to increase the signal to noise ratio and speed of readout, at the expense of lower resolution. For further information refer to the technical note: [CCD Binning](#).

However, for cameras with sCMOS sensors such as in the Andor ZL41, Zyla, Neo, Sona and Marana models, the binning process is performed slightly differently. Binning is processed by the FPGA after the pixels have been readout- therefore there is not the speed increase observed in CCD cameras from the reduced number of pixels being read out. After FPGA processing the pixel information is transmitted to the control PC - this may be faster when binning is applied under some conditions. For further information refer to the technical note: [Binning in sCMOS cameras](#).

---

## 5.7.2 Spurious Noise Filter

The Spurious Noise filter corrects for pixels that would otherwise appear as spurious 'salt and pepper' noise spikes in the image. The appearance of such noisy pixels is analogous to the situation of Clock Induced Charge (CIC) noise spikes in EMCCD cameras, in that the overall noise of the sensor has been reduced to such a low level, that the remaining small percentage of spurious, high noise pixels can become an aesthetic issue. The filter actively corrects such high noise pixels, replacing them with the mean value of the neighbouring pixels. The filter can be switched on and off by the user prior to data acquisition.

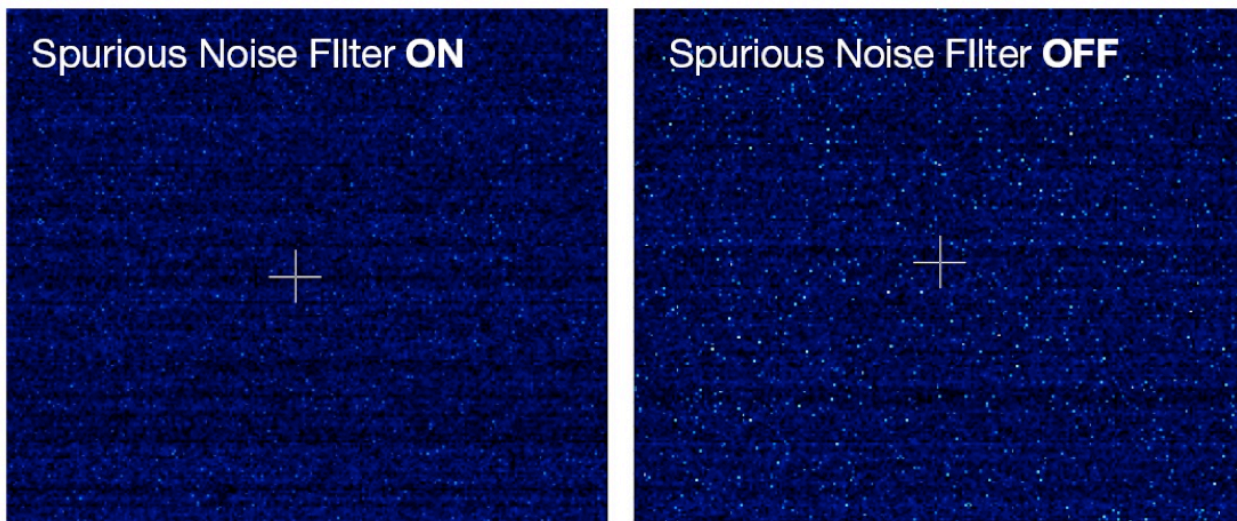

**Figure 13: Demonstration of Spurious Noise Filter (Filter On left, Filter Off, Right) on a dark image, 20 ms exposure time, 200 MHz (x2 halves) readout speed**

---

### 5.7.3 Blemish Correction Filter

This Blemish Correction filter identifies and compensates for three types of blemishes during the FPGA processing step:

1. Hot pixels
2. Noisy pixels
3. Unresponsive pixels

sCMOS sensors are particularly susceptible to hot pixel blemishes. These are spurious noise pixels that have significantly higher darkcurrent than the average. Through deep TE cooling of the sensor (e.g.  $-45^{\circ}\text{C}$  for Sona/Marana), it is possible to dramatically minimize the occurrence of such hot pixels within the sensor, meaning that these pixels can still be used for useful quantitative imaging. However, if deep cooling cannot be achieved it is necessary to use interpolative filters to minimize the hot pixel blemishes. These filters work by taking the mean of the surrounding 8 pixel values and replacing this hot pixel blemish with this mean value. Such interpolation over pixel blemishes can be detrimental in some applications that depend on total quantitative integrity over a limited set of pixels, for example in localization based super-resolution microscopy (such as PALM and STORM techniques) and astronomy. In these applications it is essential for the user to be able to switch off interpolative corrections. Furthermore, having access to the location of these blemishes allows an accurate map of 'good' pixels to be determined by the user. A new service allows the end user to request a 'hot pixel map' of their sCMOS sensor from Andor. This map will be generated based on the experimental conditions outlined by the end user. From the latest general release of Andor SDK3 (version 3.7.30004) and Solis (version 4.24.30004) blemish correction can be switched on and off by the user. Refer to the SDK and Solis User Guide and help information for instructions.



## 5.8 Sensor Readout Optimisation

To allow the camera to be optimized for the widest range of applications it is important to have flexibility in the readout options available, some of these include the following:

- Gain Channel Control
- Pixel Readout Rate
- ROI sub image settings
- Triggering / Synchronization options (see "Trigger Modes" on page 76)

The effect of different shutter modes, readout speed and different ROIs on frame rates is shown in "Maximum sustainable frame rates for all electronic shutter modes, readout speeds and gain channel combinations for various (vertically centred) ROIs" below.

**Table 7: Maximum sustainable frame rates for all electronic shutter modes, readout speeds and gain channel combinations for various (vertically centred) ROIs**

Region of Interest	Shutter Mode	Bit-depth	ZL41 Cell 5.5 10-tap		ZL41 Cell 4.2 10-tap		ZL41 Cell 5.5 USB 3.0		ZL41 Cell 4.2 USB 3.0	
			200 MHz	560 MHz	216 MHz	540 MHz	200 MHz	560 MHz	216 MHz	540 MHz
2560 x 2160	Rolling	12-bit	36	100	-	-	36	40	-	-
		16-bit	36	75	-	-	30	30	-	-
	Global	12-bit	18	49	-	-	18	40	-	-
		16-bit	18	49	-	-	18	30	-	-
2048 x 2048	Rolling	12-bit	38	105	40	100	38	53	40	53
		16-bit	38	98	40	100	38	40	40	40
	Global	12-bit	19	52	-	-	19	52	-	-
		16-bit	19	52	-	-	19	52	-	-
1920 x 1080	Rolling	12-bit	72	199	76	192	72	107	76	107
		16-bit	72	199	76	192	72	80	76	80
	Global	12-bit	35	97	-	-	35	98	-	-
		16-bit	35	97	-	-	35	80	-	-
512 x 512	Rolling	12-bit	152	419	161	403	152	419	161	403
		16-bit	152	419	161	403	152	419	161	403
	Global	12-bit	73	201	-	-	73	201	-	-
		16-bit	73	201	-	-	73	201	-	-

Region of Interest	Shutter Mode	Bit-depth	ZL41 Cell 5.5 10-tap		ZL41 Cell 4.2 10-tap		ZL41 Cell 5.5 USB 3.0		ZL41 Cell 4.2 USB 3.0	
			200 MHz	560 MHz	216 MHz	540 MHz	200 MHz	560 MHz	216 MHz	540 MHz
128 x 128	Rolling	12-bit	596	1639	631	1578	596	1639	631	1578
		16-bit	596	1639	631	1578	596	1639	631	1578
	Global	12-bit	260	716	-	-	260	716	-	-
		16-bit	260	716	-	-	260	716	-	-

**Note**

**The write speed of the PC hard drive can impose a further restriction on the maximum sustainable frame rate.**

---

### 5.8.1 Gain Channel Control

The ZL41 Cell offers the user a choice of two 12-bit gain channels (i.e. high or low gain) or a combined '16-bit' setting. The user can choose to stay with 12-bit single gain channel data if dynamic range is not critical, resulting in smaller file sizes. This in turn offers faster frame rates when continuously spooling through the Camera Link interface and writing to hard disk. The 16-bit dual gain channel should be chosen if dynamic range is more important than having the fastest frame rates. Please refer to "[Dual Amplifier Dynamic Range](#)" on page 55 for more detailed explanation of the dual amplifier dynamic range operation.

---

## 5.9 Pixel Readout Rate

The Pixel Readout Rate defines the rate at which pixels are read from the sensor. The faster the readout rate the higher the frame rate that can be achieved. The ability to change the pixel readout rate is important to achieve the maximum flexibility of camera operation.

Slower readout typically allows lower read noise but at the expense of slower frame rates. The following readout rates are available on the ZL41 Cell ("[Typical Read Noise for Rolling and Global Shutter modes](#)" below shows the typical read noise at each readout rate):

- ZL41 Cell 5.5: 200 MHz (100 MHz x 2 halves) and 560 MHz (280 MHz x 2 halves)
- ZL41 Cell 4.2: 216 MHz (108 MHz x 2 halves) and 540 MHz (270 MHz x 2 halves)

**Table 8: Typical Read Noise for Rolling and Global Shutter modes**

Model	Rate	Read noise (e-) Rolling Shutter (typical)	Read noise (e-) Global Shutter (typical)
ZL41 Cell 5.5	200 MHz	1.2	2.6
	560 MHz	1.45	2.6
ZL41 Cell 4.2	216 MHz	0.9	N/A
	540 MHz	1.1	N/A

Please refer to "[Understanding Read Noise in sCMOS](#)" on page 60 for more information on read noise and the camera performance sheet for read noise values at the various readout speeds.

---

## 5.10 Rolling and Global Shutter

The sCMOS sensor used by the ZL41 Cell 5.5 offers a choice of both Rolling and Global shutter, providing superior application flexibility. Rolling and Global shutter modes describe two distinct sequences through which the image may be read off a sCMOS sensor. In rolling shutter, charge is transferred from each row in sequence during readout, whereas in global shutter mode each pixel in the sensor effectively ends the exposure simultaneously. However, lowest noise and fastest frame rates are achieved from rolling shutter mode.

Traditionally, most CMOS sensors offer either one or the other, but very rarely does the user have the choice of both from the same sensor. For the ZL41 Cell 5.5, it is possible to select between either readout mode from the same sensor, so the most appropriate mode can be selected for the specific application. The ZL41 Cell 4.2 offers rolling shutter only.

---

### 5.10.1 Rolling Shutter

In Rolling Shutter mode, adjacent rows of the array are exposed at slightly different times as the readout 'waves' sweep through each half of the sensor. Therefore, each row will start and end its exposure slightly offset in time from its neighbour. In the case of the ZL41 Cell 5.5, at the maximum readout rate of 560 MHz (as each half of the sensor is at 280 MHz), this offset between adjacent row exposures is  $\sim 10 \mu\text{s}$ . The rolling shutter readout mechanism is illustrated in Figure 8 below. From the point of view of readout, the sensor is split in half horizontally. Rows are read out from the centre outwards, row after row. At the start of an exposure, the wave sweeps through each half of the sensor, switching each row in turn from a 'keep clean state', in which all charge is drained from the pixels, to an 'exposing state', in which light induced charge is collected in each pixel. At the end of the exposure, the readout wave again sweeps through the sensor, transferring the charge from each row into the readout node of each pixel. The important point is that each row will have been subject to exactly the same exposure time, but the row at the top (or bottom) edge of the sensor would have started and ended its exposure  $\sim 10 \text{ ms}$  (1080 rows  $\times 10 \mu\text{s}/\text{row}$ ) after the rows at the centre of the sensor (when using 560 MHz readout rate).

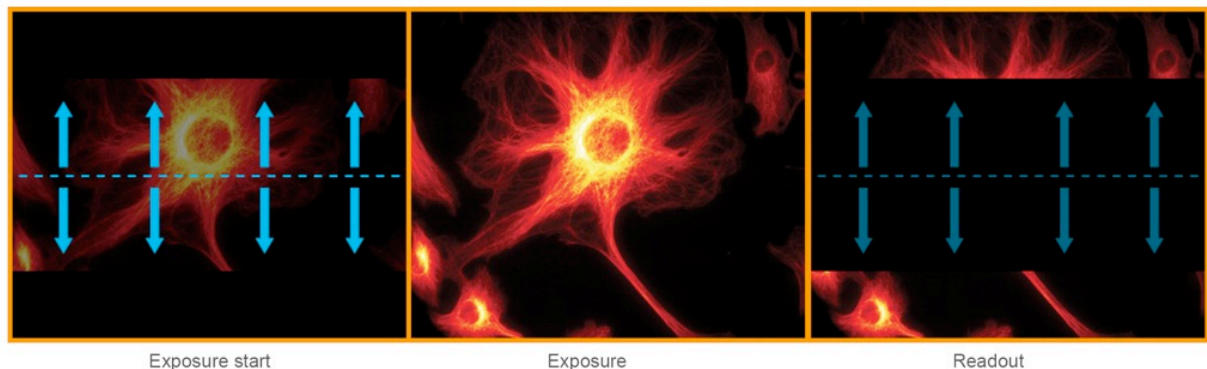

**Figure 14: Rolling Shutter Exposure and Readout**

Rolling shutter can be operated in a 'continuous' mode when capturing a kinetic series of images, whereby after each row has been read out it immediately enters its next exposure. This ensures a 100% duty cycle, meaning that no time is wasted between exposures and, perhaps more importantly, no photons are wasted. At the maximum frame rate for a given readout speed (e.g. 100 fps at 560 MHz for the ZL41 Cell 5.5) the sensor is continuously reading out, i.e. as soon as the readout fronts reach the top and bottom of the sensor, they immediately return to the centre to readout the next exposure.

---

A potential downside of rolling shutter is spatial distortion resulting from the above described exposure mechanism. This has historically been more apparent in devices such as CMOS camcorders, where the entire image field could be moved (for example by the user rapidly panning the camera) at a rate that the image readout could not match; thus, objects could appear at an angle compared to their actual orientation. In reality, despite the time-offset readout pattern, rolling shutter mode is appropriate for the majority of scientific applications, especially where the exposure time is equal to or greater than the sensor readout time, discussed later.

---

## 5.10.2 Global Shutter

Global shutter mode, which can also be thought of as a 'snapshot' exposure mode, means that all pixels of the array are exposed simultaneously. In most respects, global shutter can be thought of as behaving like an Interline CCD sensor. Before the exposure begins, all pixels in the array will be held in a 'keep clean state', during which charge is drained into the anti-bloom structure of each pixel. At the start of the exposure each pixel simultaneously begins to collect charge and is allowed to do so for the duration of the exposure time. At the end of exposure each pixel transfers charge simultaneously to its readout node. Importantly, global shutter can be configured to operate in a continuous 'overlap' mode (analogous to Interline CCD), whereby an exposure can proceed while the previous exposure is being readout out from the readout nodes of each pixel. In this mode, the sensor has a 100% duty cycle, again resulting in optimal time resolution and photon collection efficiency. However, the mechanism of global shutter mode demands that a reference readout is performed 'behind the scenes', in addition to the actual readout of charge from each pixel. Due to this additional reference readout, global shutter mode carries the trade-off of halving the maximum frame rate that would otherwise have been achieved in rolling shutter mode. In addition, global shutter also increases the RMS read noise by a factor of 1.41 over rolling shutter readout. The figure below shows a simplified illustration showing sequence of events in global shutter mode:

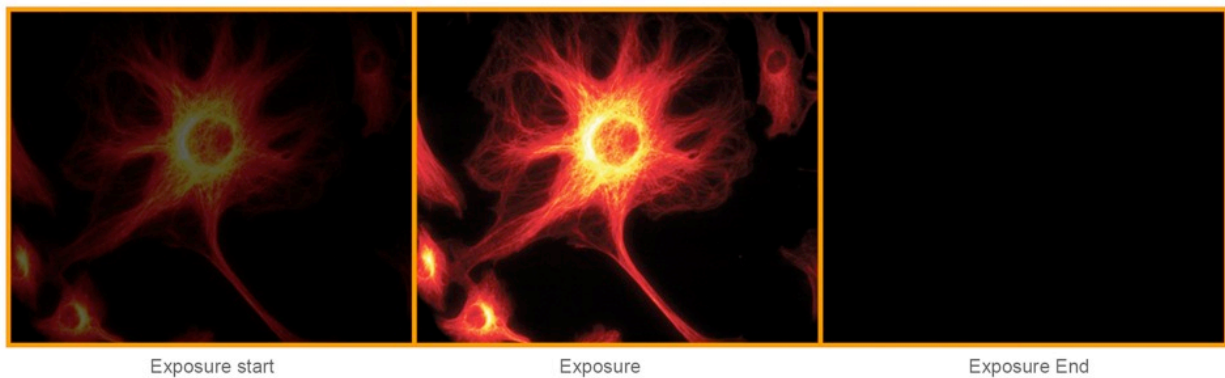

**Figure 15:Global Shutter Exposure and Readout**



---

### 5.10.3 Selecting Rolling or Global Shutter

The selection of Rolling Shutter or Global Shutter modes for the ZL41 Cell 5.5 depends on your specific experimental conditions. A summary of the key parameters for each mode is shown in the table below.

**Table 9:A comparison of rolling and global shutter modes**

Parameter	Rolling Shutter Mode	Global Shutter Mode (ZL41 Cell 5.5 only)
Frame Rate	Maximum available	Maximum frame rate is halved
Read Noise	Lowest	Increased by 1.41
Spatial Distortion	Dependent on object dynamics and frame rate	None

**Rolling Shutter Mode:** with the enhanced frame rates and lower noise, is likely to suit the majority of scientific applications. As long as the frame rate is such that the camera is temporally oversampling object dynamics within the image area, negligible spatial distortion will be observed. Such oversampling is good imaging practice, since it is undesirable to have an object travel a significant distance during a single exposure.

**Global Shutter Mode:** for some specific applications global shutter will be viewed as a necessity.

---

#### 5.10.4 Examples of Typical Applications for Global Shutter Mode

- Applications that require 'microsecond' time gating synced to a pulsed light source: e.g. Laser Induced Breakdown Spectroscopy (LIBS). Global readout involves a step that simultaneously transfers the signal charge of each pixel into the corresponding readout node for that pixel. This transfer step is  $2\ \mu\text{s}$  (at 560 MHz readout rate), facilitating fast exposure end, i.e. 'Electronic gating'
- 'Double Exposure' applications: e.g. Particle Imaging Velocimetry (PIV), which requires that two back-to-back exposures are acquired with minimal time separation between them. The global shutter  $2\ \mu\text{s}$  transfer time into the readout node defines the minimum time between two consecutive exposures
- Applications that require exact time correlation between two (or more) points of an image that are separated vertically within the image: In rolling shutter it takes  $10\ \mu\text{s}$  per row for the 2x readout fronts to move across the image from the centre outwards, reading out one row at a time. At 560 MHz pixel readout rate, this represents 10 ms to cover the distance from centre to outermost rows. That means an object at the centre of the image will begin and end an exposure  $\sim 10\ \text{ms}$  before an object located at the very top or bottom (although remember that each object will be subject to the same overall exposure time). If a particular application requires that 'moving or changing' objects separated by relatively large distances (vertically) be subject to the same beginning and end of exposure, then global shutter mode is required
- Applications where the entire field of view is fast moving (relative to exposure time): e.g. high speed machine vision inspection, such as PCB inspection

---

### 5.10.5 Rolling and Global Shutter Mechanisms

In Rolling Shutter mode, charge transfer happens on a per row basis whilst in global shutter charge transfer happens for the whole sensor or globally. To read out a pixel in Rolling Shutter mode, the following occurs within the analog circuitry:

1. The read out node is reset
2. The node level (reference level) is measured
3. Charge is transferred from photodiode to node
4. The node level (signal level) is measured
5. Reference level (step 2) is subtracted from signal level (Step 4) to get real signal

This process is commonly referred to as CDS (Correlated Double Sampling) and is done in the analog domain before digitization. The reason it is required is due to what is known as reset noise, this arises because every time the node is reset it does not settle at exactly the same level and hence the actual level must be measured (Step 2.) and subtracted from the signal level (Step 4) to get the real signal.

Rolling Shutter Mode: charge transfer happens on a per row basis; therefore each row follows steps 1 – 5, until the entire sensor is read out. The disadvantage of this is that the start and end exposure time moves by the row read out time for each subsequent row. So whilst each row of pixels is exposed for exactly the same length of time they do not all start and end at exactly the same time.

Global Shutter Mode: the start and end of the exposure do occur at exactly the same time for every pixel (not just for pixels in the same row); therefore Step 3. has to occur for all the pixels at the same time. Because of this, the reset and reference read occur before this global transfer for every row. Since the same read out circuitry is used for every row there is nowhere to store the measured reference level for every pixel and so a reference frame is actually digitized and read out from the sensor and then the signal is digitized and read out from the sensor. The two are subtracted to get the 'real signal'. Reading two frames to get a real signal frame effectively halves the Cycle Time when compared to Rolling Shutter.

---

## 5.11 Trigger Modes

The ZL41 Cell camera has the following triggering modes:

- **Internal Trigger** - the camera determines the exact time when an exposure happens based on the acquisition settings entered by the user. This is the most basic trigger mode and requires no external intervention.
- **External Trigger** - the camera and software are in a high state of readiness to accept a trigger from an external source. Refer to "[Timing Parameters and Ext Triggering](#)" on page 82 for the minimum pulse width required to guarantee a trigger. The external trigger is fed via the External Trigger input on the I/O Connector on the camera head.
- **Software Trigger** works in the a similar manner to External Trigger mode whereby the camera and software are in a high state of readiness and can react extremely quickly to a trigger event issued via software. This mode is particularly useful when the user needs to control other equipment between each exposure and does not know in advance how long such control will take or if the time taken changes randomly.
- **External Start** is a mode where the camera will wait for one external trigger event to occur after the acquisition sequence has been started. Once this external trigger event is detected, the camera will start the Internal Trigger read out process and will progress as if the camera was in internal trigger mode.
- **External Exposure Trigger** is a mode of operation where the exposure time and cycle time are controlled by the external trigger input.

The TTL inputs and outputs may be used to synchronize the camera operation with external events or equipment.

The individual outputs are described in the following sections.

The AUX\_OUT\_1 output can be configured via software (Solis or SDK) to provide one of the following outputs: FIRE, FIRE n, FIRE ALL, or FIRE ANY.

The default state provides 'FIRE ALL on this output.

The polarity of the TTL inputs and outputs can also be inverted (individually) via either Solis or SDK.

---

### Note

**'Row 1' is the first row read out in the image frame. 'Row n' is the last row read out in the image frame.**

**The trigger diagrams in the following sections are for outlining the events and timing of outputs in the various trigger modes and not to scale.**

### 5.11.1 Software Acquisition Events

Software Acquisition Events are only accessible via SDK- these are not available in Solis, iQ or other software but may be used internally. Refer to the SDK3 manual for further information on configuration of Software Acquisition Events.

Compare the two diagrams below: The first diagram "Rolling Shutter - Original Acquisition using SW Trigger. Example: RS, 560 MHz 30 ms exposure, full image." below shows the situation prior to the introduction of the software events. In this case the user had to wait until the image frame was completely transferred to the PC before they received any notification that the exposure had completed. This results in a cycle time of approximately 79 ms or a frame rate of 12.6 fps, for this example. With acquisition software events ("Rolling Shutter - New Acquisition using Events and Faster SW Trigger. Example: RS, 560 MHz 30 ms exposure, full image." on the next page) and in particular the ExposureEndEvent the user will be notified as soon as the exposure is complete in advance of readout completion. This in conjunction with faster SW trigger, means that the next acquisition can be started much sooner, resulting in an improvement in frame rate, 25 fps. In addition, the Fire ALL signal can be used to control light sources/z-stages.

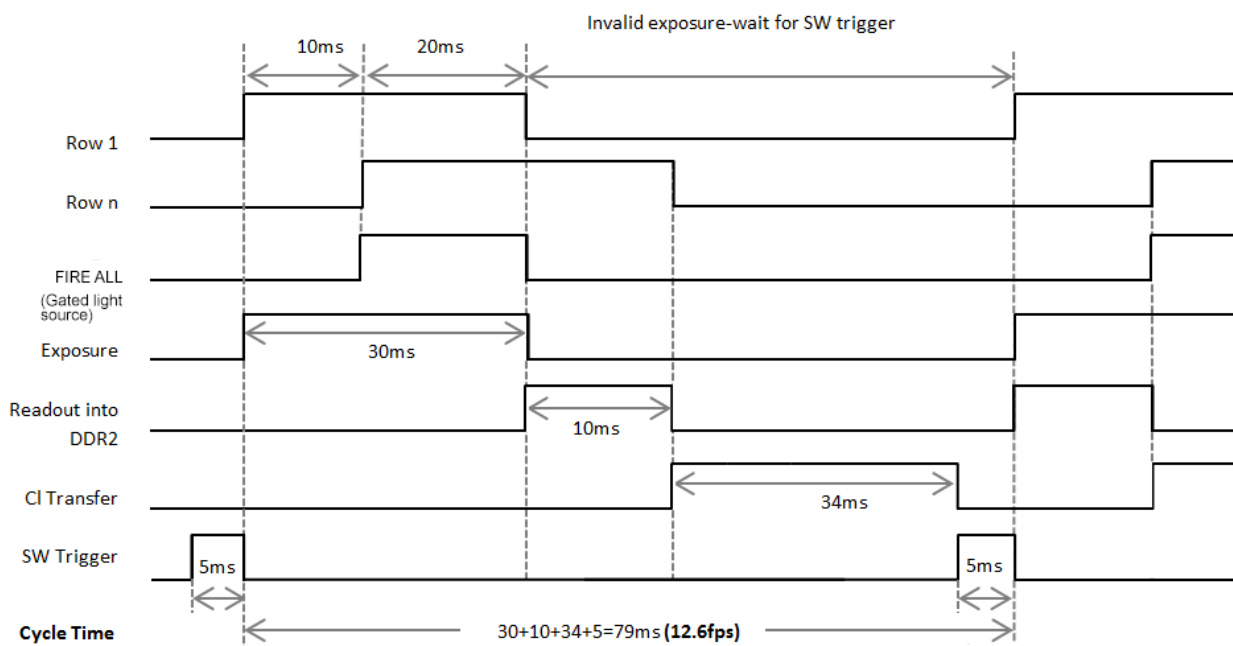
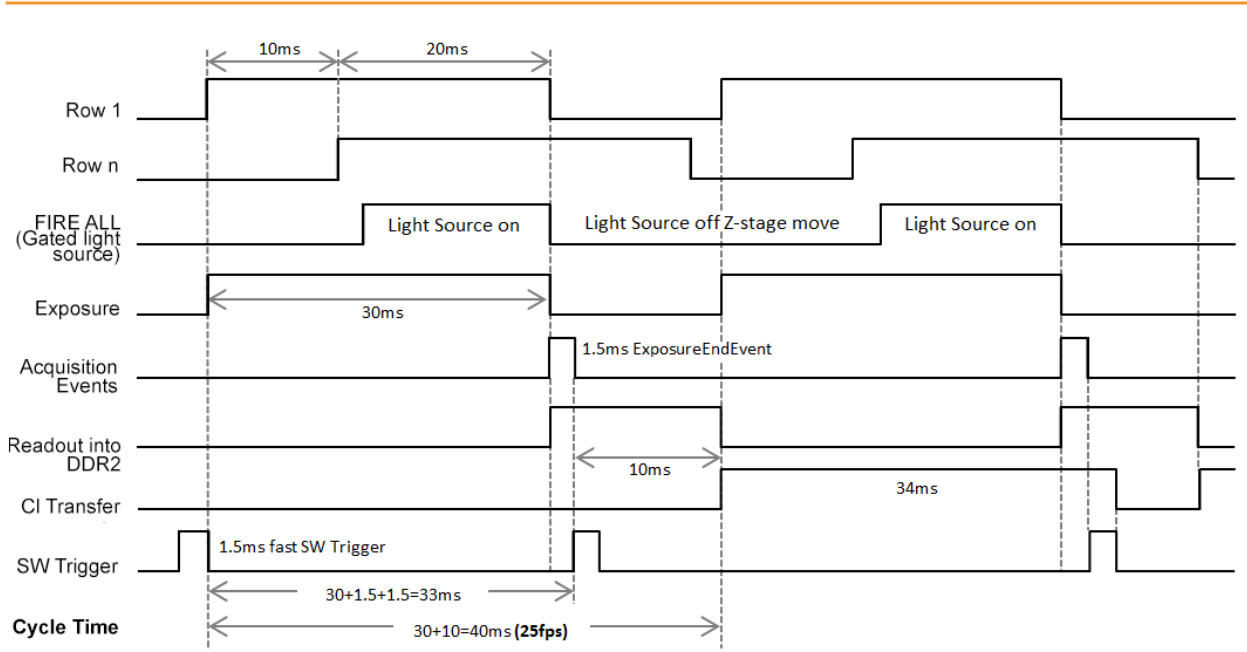

Figure 16: Rolling Shutter - Original Acquisition using SW Trigger. Example: RS, 560 MHz 30 ms exposure, full image.



**Figure 17:Rolling Shutter - New Acquisition using Events and Faster SW Trigger. Example: RS, 560 MHz 30 ms exposure, full image.**

---

## 5.11.2 Signal Information

- **Acquisition Start:** This is an internal pulse purely for illustrative purposes and indicates when the camera receives a command from software to start the pre-programmed acquisition sequence
- **FIRE:** (Exposure for Row 1): In Rolling Shutter mode, the FIRE output from the camera indicates to the user the exposure time for the first row
- **FIRE Row n:** (Exposure for Row n): The exposure for Row 2 is delayed by one row time relative to Row 1, Row 3 is delayed by one row time relative to Row 2, etc. for all rows in the frame (up to Row n) - the rows within the selected ROI which are furthest from the sensor centre. This signal is connected to an external output from the camera known as FIRE Row n.
- **FIRE ALL:** The Fire ALL output from the camera indicates when all rows within a frame are being simultaneously exposed.
- **FIRE ANY:** The FIRE ANY output indicates when any row within a frame is being exposed.
- **ARM:** The ARM output from the camera is used in external and software triggering modes to indicate when the camera is ready to accept an incoming trigger. If ARM is low when a trigger event occurs, it will be ignored
- **Global Clear:** The entire sensor can be held in a global clear state which ensures that there is no charge build-up on the sensor
- **Prescan Readout Cycle:** Once an acquisition sequence has been started, the camera is placed into a special cleaning cycle called 'Prescan Readout Cycle' which ensures that charge build up on the sCMOS sensor is kept to a minimum while waiting for the trigger event. The Prescan Readout Cycle consists of repeatedly reading a virtual row from the sensor. Once the trigger is received, a new exposure phase is initiated.
- **Charge Transfer:** This signal indicates when charge in the pixel is transferred to the measurement node and effectively ends the exposure. The charge is transferred while the pulse is HIGH.

Note
For clarity this signal is not shown in Rolling Shutter diagrams.



- 
- **Frame Readout Phase:** This signal shows the period during which the signal frame is read out from the sensor
  - **EXT Start Delay:** This is the delay between the start of the External Trigger pulse and the start of exposure of row 1.
  - \* : Marks the start of an exposure.
  - \* : Marks the end of exposure.

---

### 5.11.3 Timing Parameters and Ext Triggering

The timing tables accompanying each of the triggering diagrams that follow indicate the exposure and cycle times achievable in each triggering mode for the ZL41 Cell. These are based on Frame and Row Periods as shown below.

#### 5.11.3.1 Timing Parameters and Ext Triggering for ZL41 Cell 5.5

**Table 10:Timing Parameters based on Sensor Clock Speed (ZL41 Cell 5.5)**

Parameter	Sensor Readout Rate	
	200 MHz	560 MHz
1 Row (2624 clock cycles)	25.41 $\mu$ s	9.24 $\mu$ s
1 Full Frame (2160 rows)	27.44 ms	9.98 ms

The time taken to read out a full row is equal to 2624 clock cycles. The sensor is split into 2 halves with each having an independent data output from the sensor. This means the Frame Period is 1080 rows x 2624 clock cycles. For sub-images the frame readout time is related to the number of rows being displayed.

In External and External Start Triggering Modes, the minimum trigger pulse width detected by the ZL41 Cell 5.5 camera is shown below in "[Minimum EXT Trigger Width \(ZL41 Cell 5.5\)](#)" below

**Table 11:Minimum EXT Trigger Width (ZL41 Cell 5.5)**

Parameter	Sensor Readout Rate	
	200 MHz	560 MHz
EXT Trig Pulse Width ( 2 clock cycles)	19.37 ns	7.04 ns

#### 5.11.3.2 Timing Parameters and Ext Triggering for ZL41 Cell 4.2

The timing tables accompanying each of the triggering diagrams that follow indicate the exposure and cycle times achievable in each triggering mode for the ZL41 Cell 4.2. These are based on Frame and Row Periods as shown below.

**Table 12:Timing Parameters based on Sensor Clock Speed (ZL41 Cell 4.2)**

Parameter	Sensor Readout Rate	
	216 MHz	540 MHz
1 Row (2592 clock cycles)	24.00 $\mu$ s	9.60 $\mu$ s
1 Full Frame ( 2048 rows)	24.54 ms	9.83 ms

---

The time taken to read out a full row is equal to 2592 clock cycles. The sensor is split into 2 halves with each having an independent data output from the sensor. This means the Frame Period is 1024 rows x 2592 clock cycles. For sub-images the frame readout time is related to the number of rows being displayed.

In External and External Start Triggering Modes, the minimum trigger pulse width detected by the ZL41 Cell 4.2 camera is shown below in "[Minimum EXT Trigger Width \(ZL41 Cell 4.2\)](#)" below

**Table 13:Minimum EXT Trigger Width (ZL41 Cell 4.2)**

Parameter	Sensor Readout Rate	
	216 MHz	540 MHz
EXT Trig Pulse Width ( 2 clock cycles)	20 ns	7.4 ns

### 5.11.4 Rolling Shutter Internal Triggering (Non-Overlap Mode)

Internal Trigger Mode allows the user to configure an exposure time and cycle time. For Internal Triggering Non-overlap mode, the exact acquisition sequence depends on the exposure time and cycle time set as shown in "Rolling Shutter Internal Triggering" below. The following diagrams show the behaviour of TTL outputs 'Fire', 'Fire n', 'Fire ALL' and 'Fire ANY'.

**Fire ALL** indicates the time period within a frame during which all rows are exposing simultaneously.

**Fire ANY** indicates the time period within a frame during which any row is exposing.

Initially, the entire sensor is held in a global clear state to ensure that there is no charge build-up on the sensor. Global Clear goes LOW and a frame read out is initiated. This frame is discarded as it does not contain the correct exposure period. Reading out a frame effectively begins a new exposure. When the exposure period has completed, a signal frame read out phase begins. When the frame has been read out completely, the Global Clear is held HIGH until the user-defined cycle time is achieved.

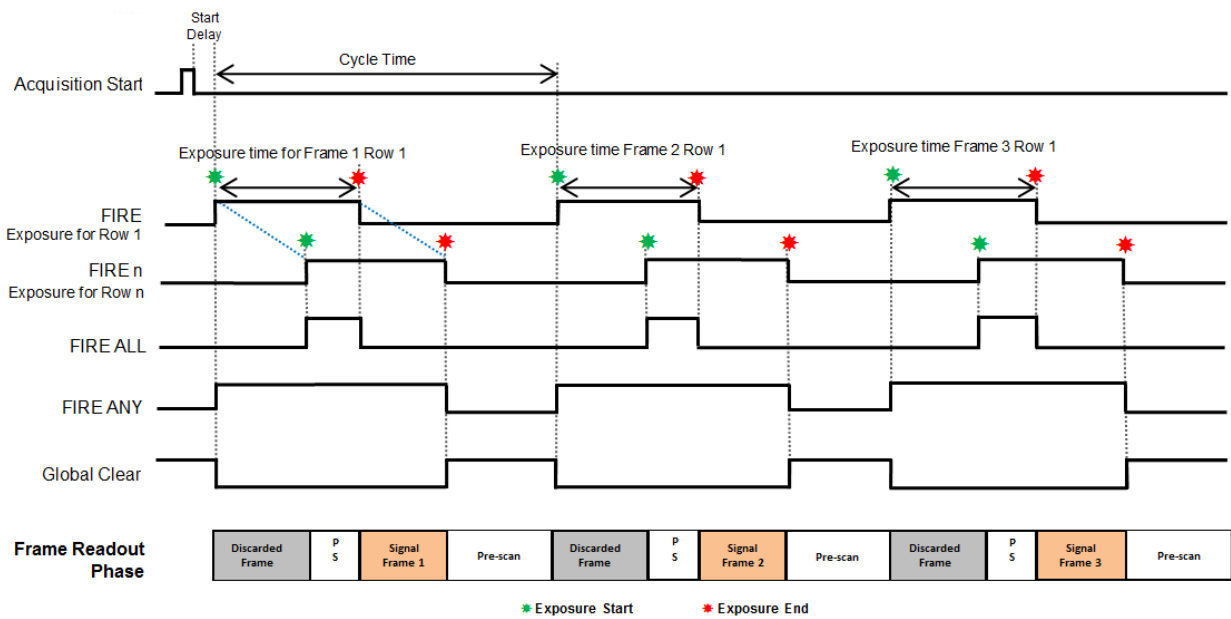

Figure 18:Rolling Shutter Internal Triggering

Table 14:Rolling Shutter Internal Triggering (Long Exposures) Timing Parameters

---

<b>Parameter</b>	<b>Minimum</b>	<b>Maximum</b>
Exposure	1 Row	30 s
Cycle Time (1/Frame Rate)	Exposure + 1 Frame + 1 Row	20,000 s
Acquisition Start Delay	-	1 Row

## 5.11.5 Rolling Shutter Internal Triggering (Overlap Mode)

Internal Triggering in Overlap Mode allows the user to perform an exposure and acquire images from the sensor simultaneously. This is achieved by starting a new exposure for a new frame while the current frame's exposure is being read out from the sensor.

The cycle time is the same as the exposure time entered by the user in this scenario.

### Short Exposures

When the required exposure time is less than the time it takes to read out a frame (Short Exposures), the cycle time is always defined by the time taken to read out a frame.

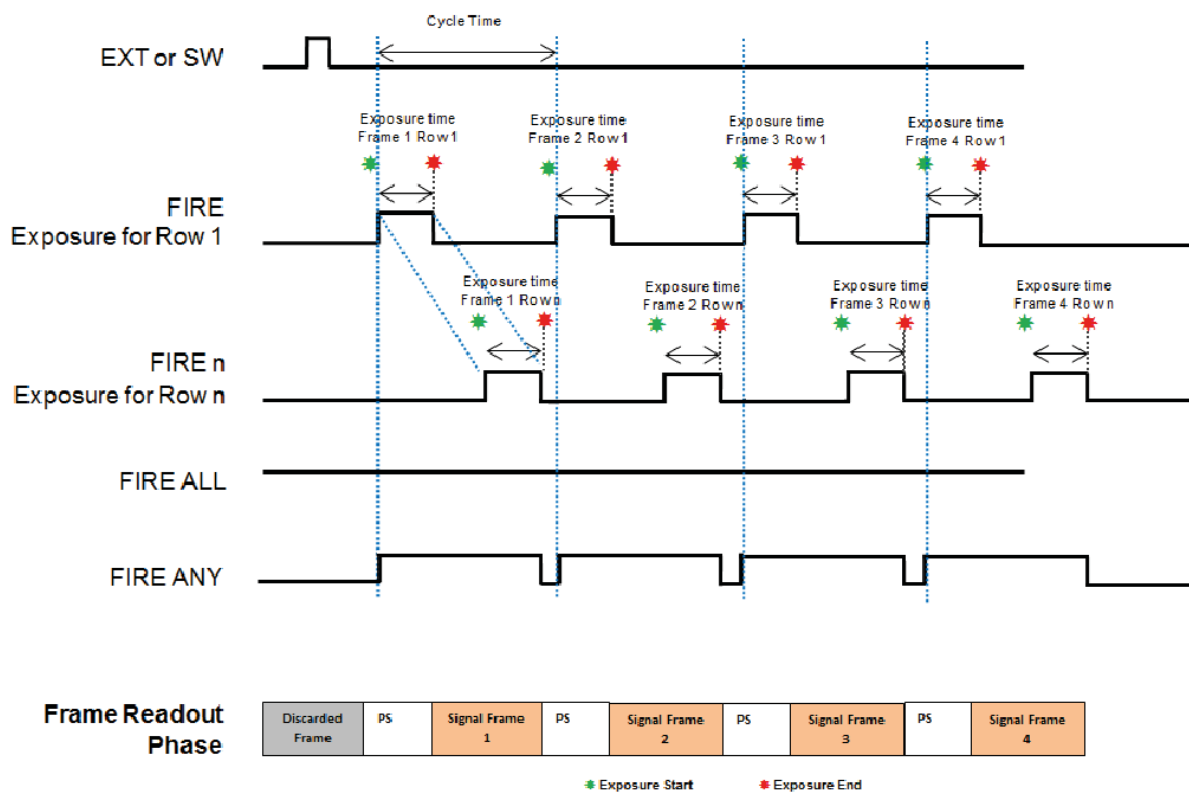

Figure 19: Rolling Shutter Internal Triggering (Short Exposures)

Table 15: Rolling Shutter Internal Triggering (Overlap Mode- Short Exposures) Timing Parameters

Parameter	Minimum	Maximum
Exposure	1 Row	1 Frame - 1 Row
Cycle Time (1/Frame Rate)	1 Frame	1 Frame + Exposure + 1 Row

Parameter	Minimum	Maximum
Acquisition Start Delay	1 Row	-

## Long Exposures

When the required exposure time is greater than the time it takes to read out a frame (Long Exposures), the cycle time is defined by the exposure time.

Initially, the entire sensor is held in a global clear state to ensure that there is no charge build-up on the sensor. Global Clear goes LOW and the first frame read out is initiated. This frame is discarded as it does not contain the correct exposure period. Reading out this first frame effectively begins the first exposure. When the exposure period has completed, a signal frame read out phase begins. As each row is read out, the new exposure for that row begins.

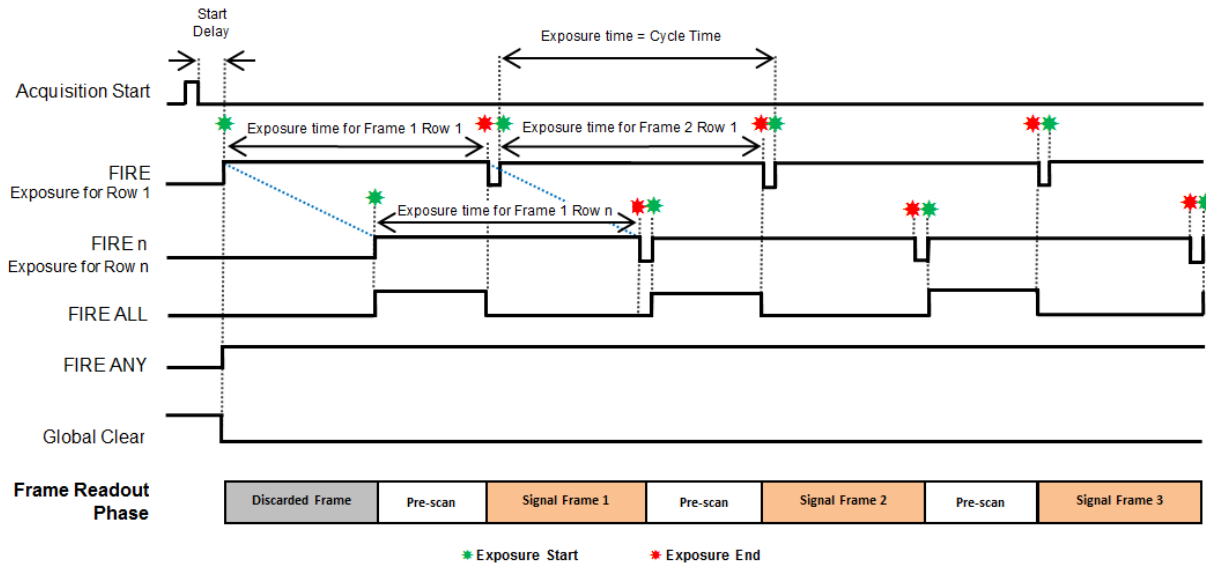

Figure 20:Rolling Shutter Internal Triggering (Overlap Mode) (Long Exposures)

Table 16:Rolling Shutter Internal Triggering (Overlap Mode- Long Exposures) Timing Parameters

Parameter	Minimum	Maximum
Exposure	1 Row	30 s
Cycle Time (1/Frame Rate)	Exposure Time	Exposure time+ 1 Frame
Acquisition Start Delay	1 Row	-

### 5.11.6 Rolling Shutter External Triggering (Non Overlap Mode)

In this section, both External and Software Trigger are described in the same diagram as the acquisition sequence is the same. The trigger event can either be from the EXT Trigger input or sent via software. While waiting on the trigger event, the sensor is put into a “pre-scan read out cycle” and is held in a Global Clear State which ensures that charge build up on the sensor is kept to a minimum while waiting for the trigger event. The ARM signal is asserted to indicate it is ready to detect an incoming trigger input.

Once the trigger event is detected, Global Clear goes LOW and a frame read out is initiated. This frame is discarded as it does not contain the correct exposure period. Reading out a frame effectively begins a new exposure. When the exposure period has completed, a signal frame read out phase begins. When the frame has been read out completely, the Global Clear is held HIGH until the next trigger event is detected.

The external trigger is fed via the EXT Trigger input on the I/O Connector on the camera head.

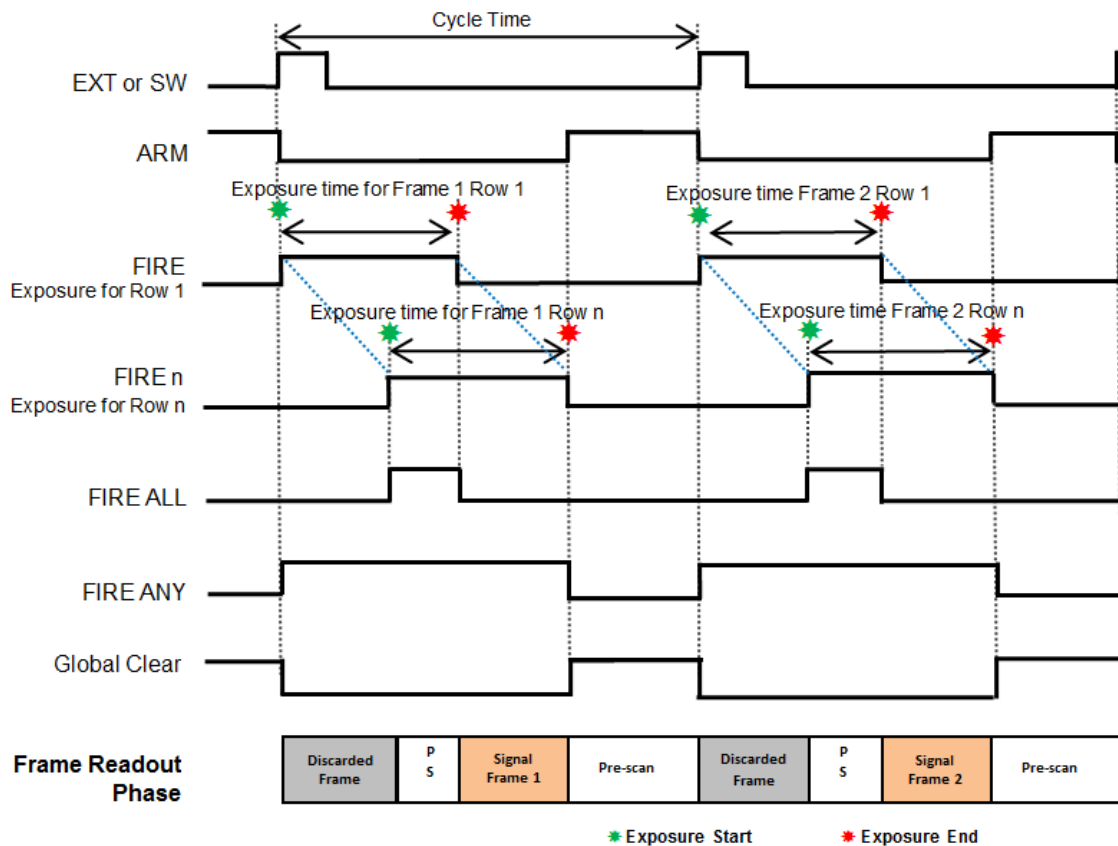

Figure 21: Rolling Shutter External/Software Trigger (Non Overlap Mode)



---

**Table 17: Rolling Shutter External/Software Triggering Timing Parameters**

<b>Parameter</b>	<b>Minimum</b>	<b>Maximum</b>
Exposure	3 Rows	30 s
Cycle Time (1/Frame Rate)	Exposure + 1 Frame + 1 Row	-
External Start Delay	0	1 Row
EXT Trig Pulse Width	2 Sensor Speed Clock Cycles	-

### 5.11.7 Rolling Shutter External Exposure Triggering (Non-Overlap Mode)

While waiting on the trigger event, the sensor held in a global clear state and is put into a “pre-scan read out cycle”. On detection of the trigger event, Global Clear goes LOW and a frame read out is initiated. This frame is discarded as it does not contain the correct exposure period. Reading out a frame effectively begins a new exposure. When the external trigger input goes LOW, a signal frame read out phase begins. When the frame has been read out completely, the Global Clear is held HIGH until the next trigger event is detected.

The external trigger pulse width defines the exposure time for all rows, but is only coincident with the exposure time for Row 1. The exposure for Row 2 will be delayed by one row time relative to Row 1 and so forth.

The period of the external trigger pulse defines the overall cycle time. If the width of the trigger event is less than 3 Rows, the falling edge will be missed and a subsequent falling edge will be required to end the exposure.

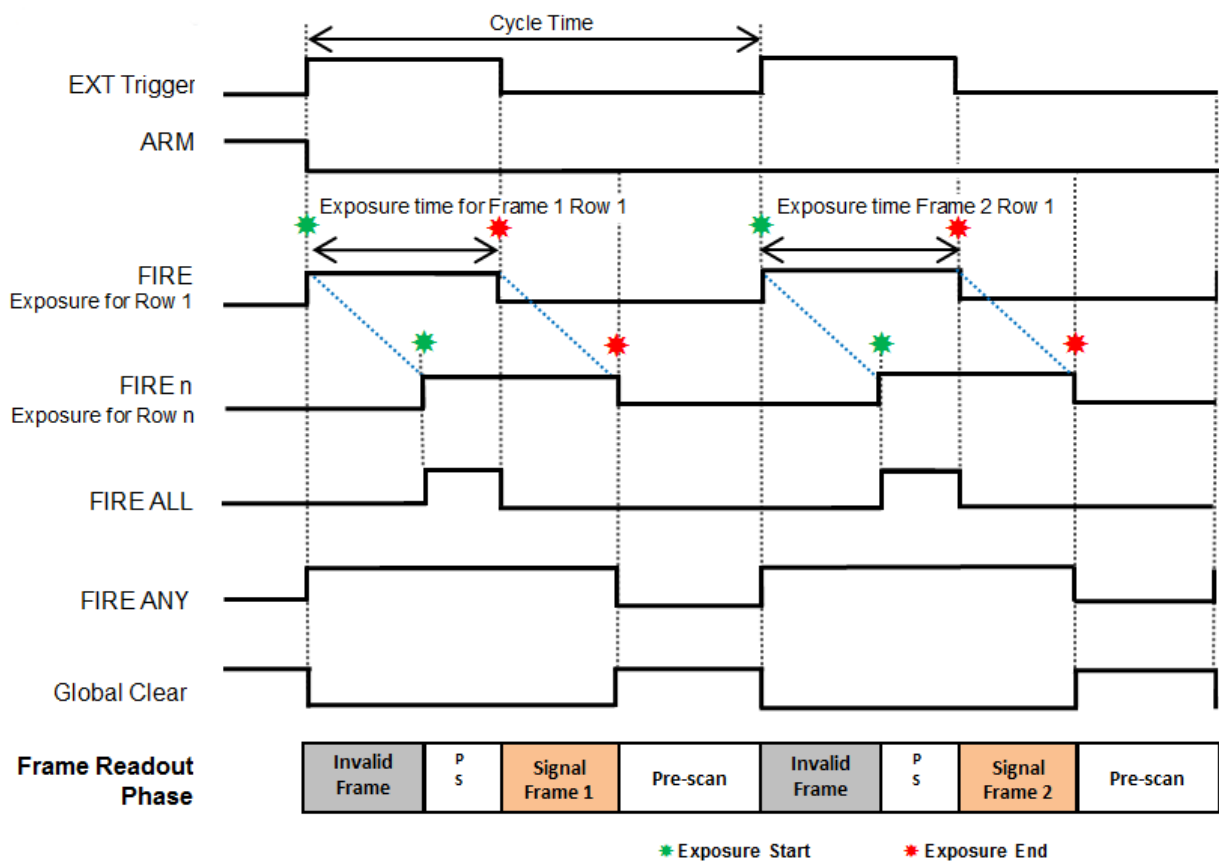

Figure 22:Rolling Shutter External Exposure Triggering (Non Overlap Mode)

---

**Table 18: Rolling Shutter External Exposure Triggering (Non Overlap Mode) Timing Parameters**

<b>Parameter</b>	<b>Minimum</b>	<b>Maximum</b>
Exposure	3 Rows	30 s
Cycle Time (EXT Trig Period)	Exposure + 1 Frame + 1 Row	-
External Start Delay	0	1 Row
EXT Trig Pulse Width	3 Rows	30 s

## 5.11.8 Rolling Shutter External Exposure Triggering (Overlap Mode)

In overlap mode, every positive edge of an external trigger will trigger a frame read out and start a new exposure for the next frame. The period of external trigger pulse defines exposure and cycle time for each frame read out.

While waiting on the positive edge of the external trigger, the sensor is held in a global clear state and put into a “pre-scan read out cycle”. On detection of the positive edge, Global Clear goes LOW and a frame read out is initiated. This frame is discarded as it does not contain the correct exposure period. Reading out this first frame effectively begins the first exposure. When the next positive edge of the external trigger is detected, a signal frame read out phase begins. As each row is read out, the new exposure for that row begins.

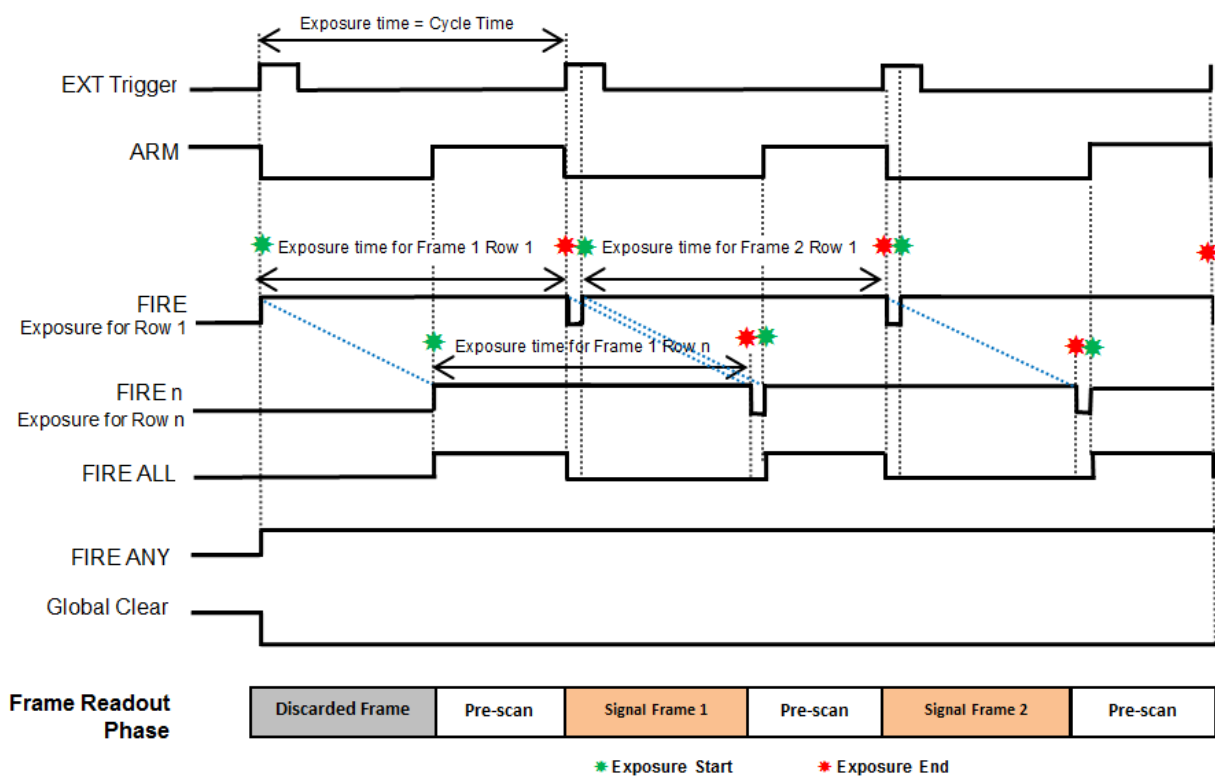

Figure 23: Rolling Shutter External Exposure Triggering (Overlap Mode) (Long Exposures)

Table 19: Rolling Shutter External Exposure Triggering (Overlap Mode) Timing Parameters

Parameter	Minimum	Maximum
Exposure	1 Frame + 1 Row	30 s
Cycle Time (EXT Trig Period)	Exposure	Exposure

---

Parameter	Minimum	Maximum
External Start Delay	0	1 Row
EXT Trig Pulse Width	2 Sensor Speed Clock Cycles	-
FIRE low period	20 Sensor Speed Clock Cycles	-

### 5.11.9 Rolling Shutter External Start Triggering

In this mode the camera will wait for a single external trigger event. Once this external trigger event is detected, the camera will progress as if the camera was in internal trigger mode (see "Rolling Shutter Internal Triggering (Overlap Mode)" on page 86 and "Rolling Shutter Internal Triggering (Non-Overlap Mode)" on page 84. The ARM signal indicates to the user when the camera is ready to detect an External Start Trigger. "Rolling Shutter External Start Triggering (Non Overlap)" below shows the External Start used in Non-overlap Mode, Long Exposure. The delay from the External Trigger to start of exposure is 1 Row.

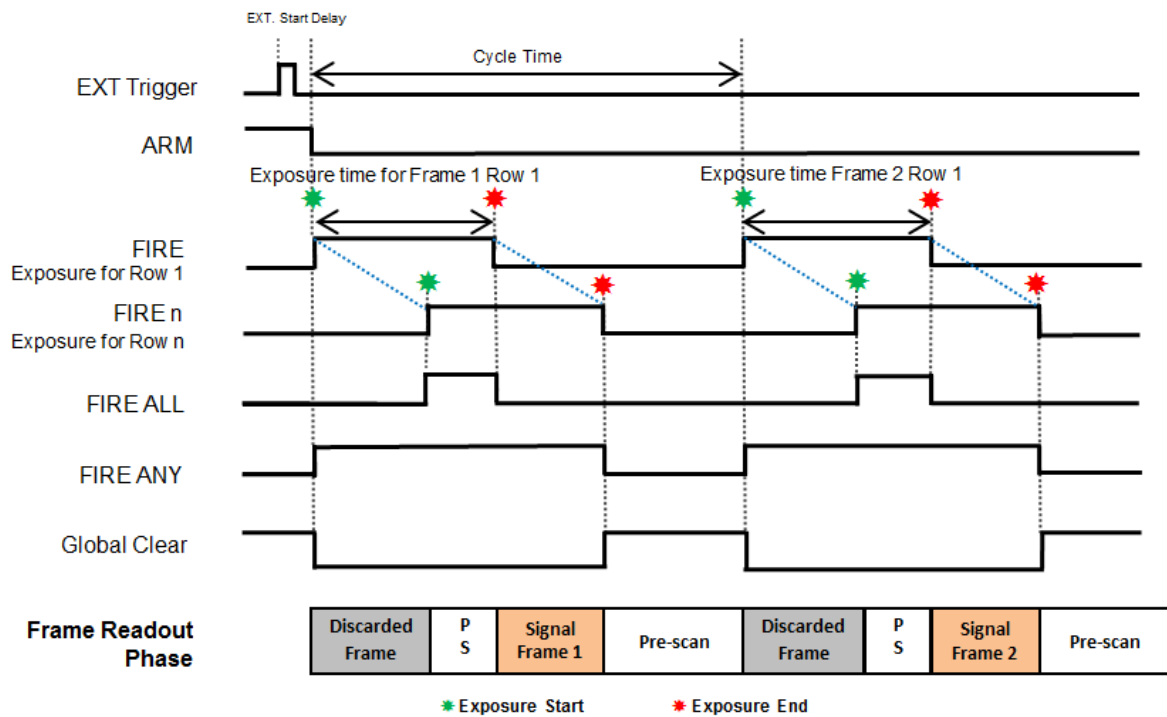

Figure 24: Rolling Shutter External Start Triggering (Non Overlap)

## 5.11.10 Rolling Shutter Global Clear Internal (Non-Overlap Mode)

**Rolling Shutter Global Clear** is an extended Rolling Shutter Mode available on Zyla 4.2 only. If enabled, the sensor rows are held in a global clear state to ensure there is no charge build-up on the sensor. When the camera is taken out of the Global Clear state, the exposure period begins for all rows in the sensor. When the required exposure period for Row 1 has completed, a signal frame rolling shutter readout phase begins. This means all rows have the same exposure start time but different exposure end times.

When the frame has been read out completely, the camera is returned to the Global Clear state until the user-defined cycle time is achieved or external trigger is detected (if in an external triggering mode).

Rolling Shutter Global Clear mode is best used in conjunction with illumination controlled by the Fire ALL signal.

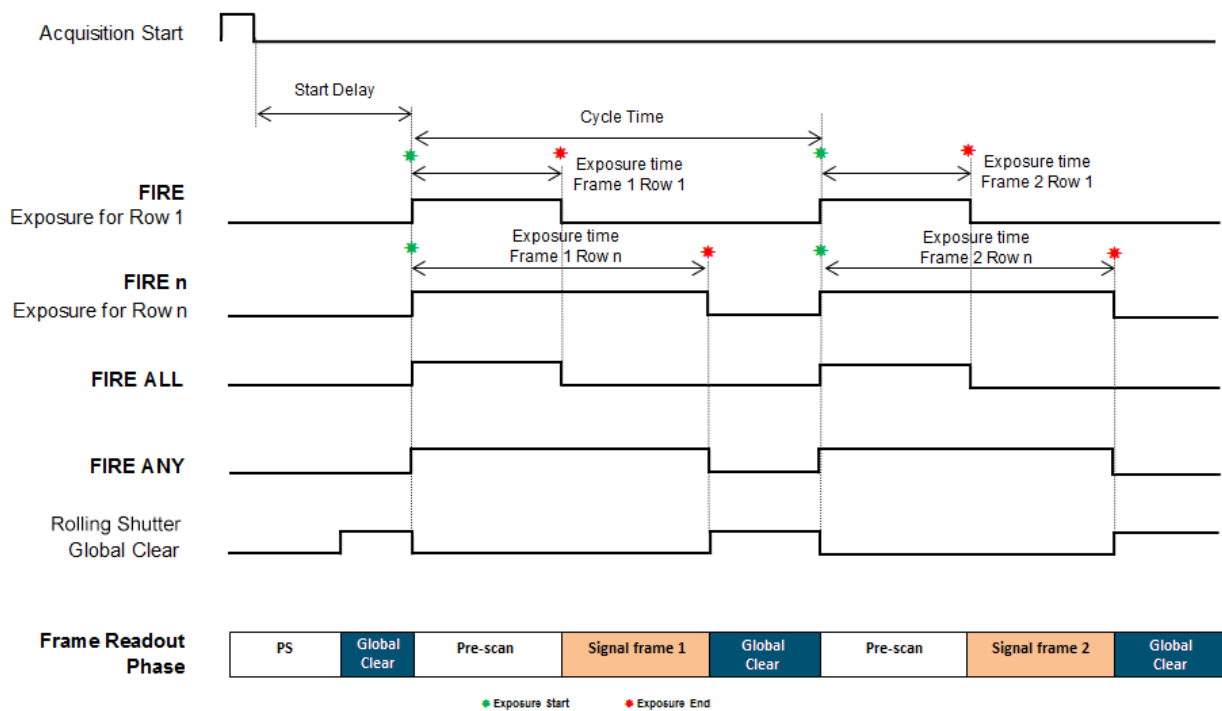

Figure 25:Rolling Shutter Global Clear- Internal (Non-Overlap Mode) - Zyla 4.2

Table 20:Rolling Shutter Global Clear Internal (Non Overlap Mode) Timing Parameters - Zyla 4.2

Parameter	Minimum	Maximum
Exposure*	1 Frame + 1 Row	30 s
Cycle Time (1/Frame Rate)	Exposure + 1 Frame + 5 Rows	20,000 s

---

Parameter	Minimum	Maximum
Acquisition Start Delay	-	2 Rows

\*The exposure time reported is the exposure time for ROW 1 and the period for which FIRE ALL is HIGH.





### 5.11.11 Rolling Shutter Global Clear External Triggering (Non-Overlap Mode)

Available for ZL41 Cell 4.2 only. In this section, both External and Software Trigger are described in the same diagram as the acquisition sequence is the same. The trigger event can either be from the EXT Trigger input or sent via software. While waiting on the trigger event, the sensor is held in a Global Clear State which ensures that charge build up on the sensor is kept to a minimum while waiting for the trigger event. The ARM signal is asserted to indicate it is ready to detect an incoming trigger input. Once the trigger event is detected, Global Clear goes LOW a signal frame read out phase begins.

When the required exposure period for Row 1 has completed, a signal frame rolling shutter readout phase begins. When the frame has been read out completely, the Global Clear is held HIGH until the next trigger event is detected.

The external trigger is fed via the EXT Trigger input on the I/O Connector on the camera head.

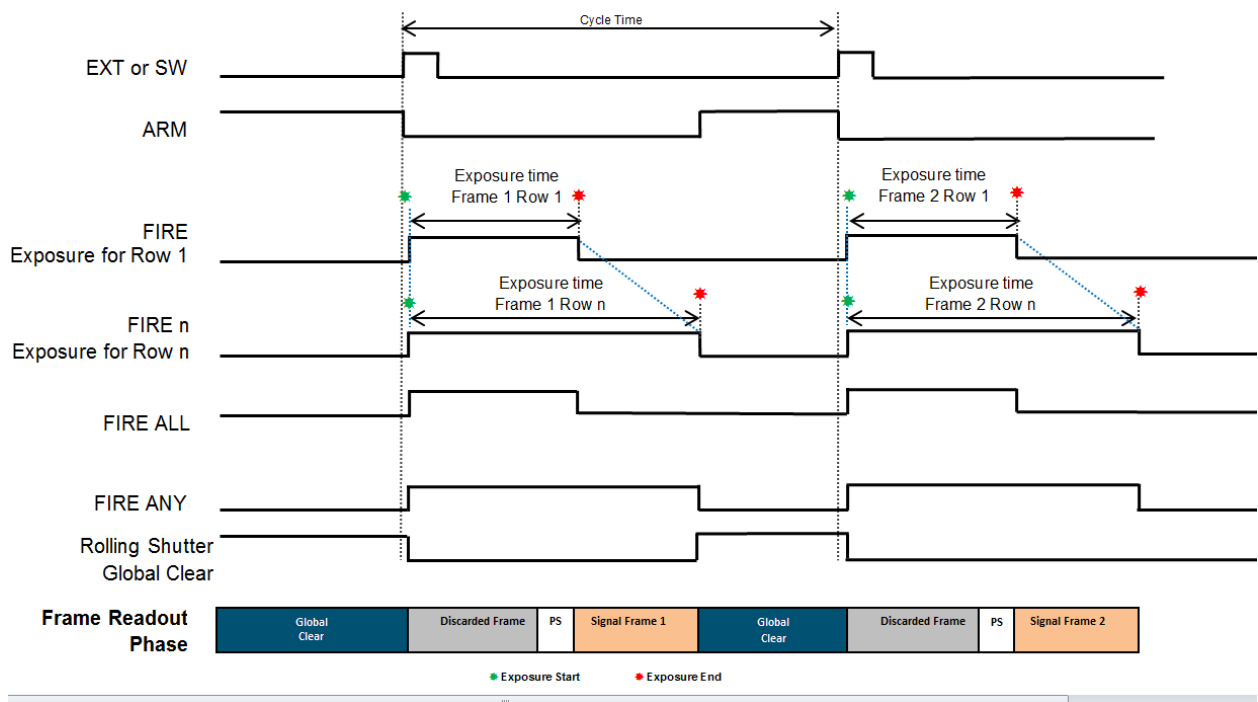

Figure 26: Rolling Shutter Global Clear External/Software Triggering (Non-Overlap Mode)

Table 21: Rolling Shutter Global Clear External/Software Triggering (Non-Overlap Mode) Timing Parameters

Parameter	Minimum	Maximum
Exposure*	1 Frame + 1 Row	30 s
Cycle Time (1/Frame Rate)	Exposure + 1 Frame + 5 Rows	-
External Start Delay	0	1 Row
EXT Trig Pulse Width	2 Sensor Speed Clock Cycles	-
*The exposure time reported is the exposure time for ROW 1 and the period for which FIRE ALL is HIGH.		

### 5.11.12 Rolling Shutter Global Clear External Exposure Triggering (Non-Overlap Mode)

Available for ZL41 Cell 4.2 only. While waiting on the trigger event, the sensor is held in a Global Clear State which ensures that charge build up on the sensor is kept to a minimum while waiting for the trigger event. The ARM signal is asserted to indicate it is ready to detect an incoming trigger input.

Once the external trigger input goes HIGH, Global Clear goes LOW and the exposure begins. When the external trigger input goes LOW, a signal frame read out phase begins. When the frame has been read out completely, the Global Clear is held HIGH until the next trigger event is detected.

The **external trigger pulse width** defines the exposure time for Row 1, and is coincident with the exposure time for Row 1. The end of exposure for Row 2 will be delayed by one row time relative to Row 1, Row 3 will be delayed by one row relative to Row 2 and so forth for the remaining rows, hence the exposure time for each row is different as all rows have the same exposure start point in time but different exposure end times.

The **period of the external trigger pulse** defines the overall cycle time. If the width of the trigger event is less than the frame read out time, the falling edge will be missed and a subsequent falling edge will be required to end the exposure.

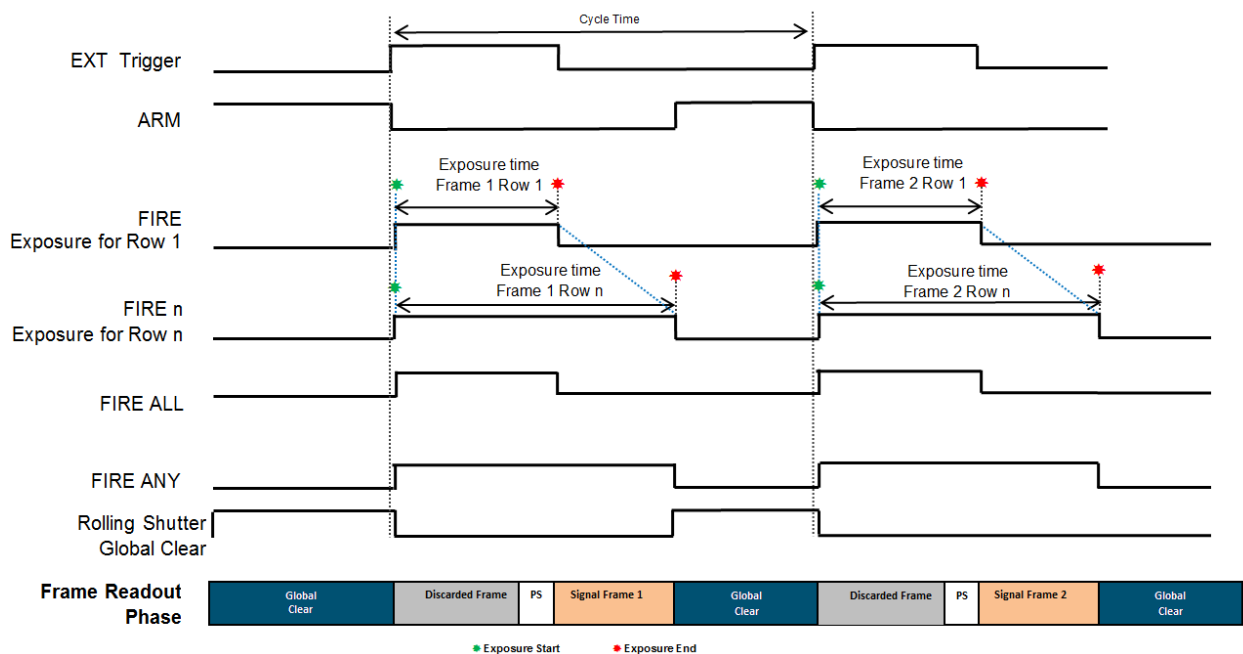

Figure 27: Rolling Shutter Global Clear External Exposure Triggering (Non-Overlap Mode)

---

**Table 22: Rolling Shutter External Exposure Triggering (Non Overlap Mode) Timing Parameters**

Parameter	Minimum	Maximum
Exposure*	1 Frame + 1 Row	30 s
Cycle Time (1/Frame Rate)	Exposure + 1 Frame + 5 Rows	-
External Start Delay	0	1 Row
EXT Trig Pulse Width	1 Frame + 1 Row	30 s

\*The exposure time reported is the exposure time for ROW 1 and the period for which FIRE ALL is HIGH.

### 5.11.13 Rolling Shutter Triggering Constraints

The table below shows a summary of constraints when operating in Rolling Shutter mode:

**Table 23: Rolling Shutter Mode Triggering Constraints**

Rolling Shutter Triggering Modes		Exposure Range	Max trigger jitter	Min trigger pulse width	Fast exposure switching supported
Internal (Non Overlap)	User settable exposure time. User settable Cycle Time.	1 Row to 30 s	-	-	Yes
Internal Overlap (Overlap On)	User settable exposure time.	1 Row to 30 s	-	-	Yes
External (Non Overlap)	Exposure time user settable. Cycle Time controlled via external trigger pulse	3 Row to 30 s	1 Row	2 Sensor Clocks	Yes
Software (Non Overlap)	Exposure time user settable. Cycle Time controlled via software trigger function	3 Row to 30 s	1 Row	2 Sensor Clocks	Yes
External Exposure (Non Overlap)	Exposure Time controlled by width of external trigger pulse. Cycle Time controlled via period of external trigger pulse.	3 Row to 30 s	1 Row	2 Sensor Clocks	No
External Exposure (Overlap On)	Exposure time controlled by period of external trigger pulse	(1 Frame + 1 Row) to 30 s	1 Row	2 Sensor Clocks	No
External Start (Non Overlap)	User settable exposure time. User settable Cycle Time.	1 Row to 30 s	2 Frames 1 Row	2 Sensor Clocks	Yes
Global Clear-Internal (Non Overlap)	User settable exposure time. Cycle Time is read out time for short exposures. User settable Cycle time for long exposures. ZL41 Cell 4.2 only.	(1 Frame + 1 Row) to 30 s	1 Row	-	Yes
Global Clear External/Software Triggering (Non-Overlap)	Exposure time user settable. Cycle Time controlled via period of external trigger pulse. ZL41 Cell 4.2 only.	(1 Frame + 1 Row) to 30 s	1 Row	2 Sensor Clocks	Yes

Rolling Shutter Triggering Modes		Exposure Range	Max trigger jitter	Min trigger pulse width	Fast exposure switching supported
Global Clear External Exposure (Non-Overlap)	Exposure Time controlled by width of external trigger pulse. Cycle Time controlled via period of external trigger pulse. ZL41 Cell 4.2 only.	(1 Frame + 1 Row) to 30 s	1 Row	1 Frame + 1 Row	Yes
<ol style="list-style-type: none"> <li>1. Exposure Time granularity for all modes is sensor row based so the exposure time in the dialog will always be rounded to the nearest integer number of row readout times.</li> <li>2. 1 Row is the time taken to perform a full row readout (2624 clock cycles ZL41 Cell 5.5; 2592 clock cycles ZL41 Cell 4.2), i.e. depends on readout rate.</li> <li>3. 1 Frame is the image height of a sensor half, defined in Rows and determined by the ROI configured, e.g. full frame. This is the number of rows that is read out by each sensor half. The frame readout time for any ROI can be requested via SDK function. (Refer to SDK3 User Guide for details).</li> <li>4. A short exposure is referred to an exposure that is less than a Frame Readout Time. (Depends on ROI selected).</li> <li>5. A long exposure is referred to an exposure time that is greater than a Frame Readout Time. (Depends on ROI selected).</li> </ol>					

---

## 5.11.14 Global Shutter Triggering Modes

**Global Shutter triggering modes are available for ZL41 Cell 5.5 only.** Global Shutter can also be thought of as a 'snapshot' exposure mode, meaning that all pixels of the array are exposed simultaneously. Before the exposure begins, all pixels in the array are cleared of charge using the Global Clear. At the start of the exposure each pixel simultaneously begins to collect charge and is allowed to do so for the duration of the exposure time. At the end of exposure, all pixels transfer their accumulated charge simultaneously to their read out node. Global Shutter requires a reference frame to be read out of the sensor in addition to the signal frame, therefore effectively halving the frame rate that would have been achieved in Rolling Shutter mode.

The Global Shutter signals shown in the diagrams are as follows:

- **Acquisition Start:** This is an internal pulse purely for illustrative purposes and indicates when the camera receives a command from software to start the pre-programmed acquisition sequence.
- **FIRE:** In Global Shutter mode, the FIRE output indicates the exposure period, which is identical for all pixels. This pulse is available to the user via the FIRE output pin.

Note
<b>In Global Shutter Mode the behaviour of FIRE Row n, FIRE ALL and FIRE ANY are identical to that of FIRE and therefore not shown in the diagrams.</b>

- **ARM:** The ARM output from the camera is used for external and software triggering modes to indicate when the camera is ready to accept another incoming trigger pulse.
- **Global Clear:** Global Shutter uses Global Clear to begin a new exposure. When this pulse is HIGH, charge is drained from every pixel thus preventing the accumulation of charge on the sensor. When the pulse is LOW, any photo-electrons generated are accumulating within the pixels, ready for transfer to the sense node for subsequent readout. The falling edge indicates the start of an exposure.
- **Charge Transfer:** This signal indicates when charge in the pixel is transferred to the measurement node and effectively ends the exposure. The charge is transferred while the pulse is HIGH and is shown in the diagrams to indicate

---

there is a specified time between reading out the reference and signal frames.

- **Frame Read Out Phase:** This signal indicates when reference and signal frames are read out of the sensor.
- **InterFrame:** The interframe defines the minimum time taken between reference and signal frame readouts.
- \* : Marks the start of an exposure.
- \* : Marks the end of exposure.

The timing tables accompanying each of the triggering diagrams that follow indicate the exposure and cycle times achievable in each triggering mode. These are based on Frame and Row Periods as shown below:

**Table 24: Timing Parameters based on Sensor Clock Speed for Global Shutter**

Parameter	Sensor Readout Rate	
	200 MHz	560 MHz
1 Row (2624 clock cycles)	25.41 $\mu$ s	9.24 $\mu$ s
1 Full Frame ( 2160 rows)	27.44 ms	9.98 ms
Charge Transfer Time	5.5 $\mu$ s	2 $\mu$ s
InterFrame (9 Rows)	228.7 $\mu$ s	83.2 $\mu$ s

1 Row is the time taken to perform 2624 clock cycles. The sensor is split into 2 halves with each having an independent data output from the sensor. This means the Frame Period is 1080 rows x 2624 clock cycles.



### 5.11.15 Global Shutter Internal Triggering (Non-Overlap Mode)

In internal non-overlap modes, a new exposure can not start until the previous exposure has been read out. The exact acquisition sequence depends on the exposure time. The two scenarios are shown in "Global Shutter Internal Triggering – Short Exposures" below and "Global Shutter Internal Triggering – Long Exposures" on the next page. If the exposure time is less than the time it takes to read out a frame, then the exposure period occurs between reading out the reference and the signal frames as shown in "Global Shutter Internal Triggering – Short Exposures" below.

In this scenario, the reference frame is read out before the Global Clear is performed. The negative edge of the Global Clear begins an exposure. After the user-defined exposure time, the Charge Transfer pulse goes HIGH to transfer charge from all pixels in the sensor. The signal frame is then read out.

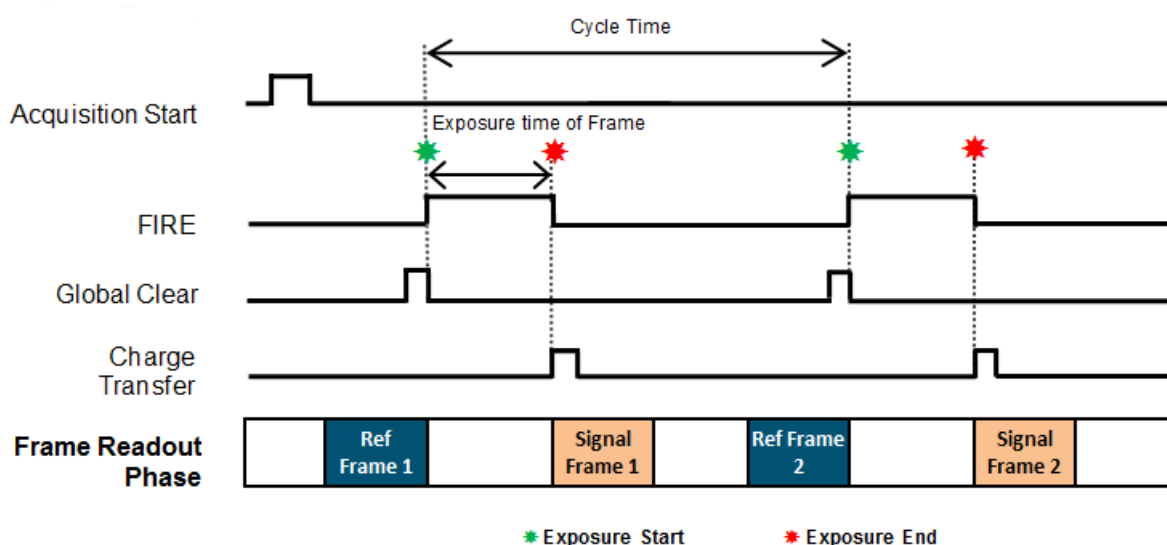
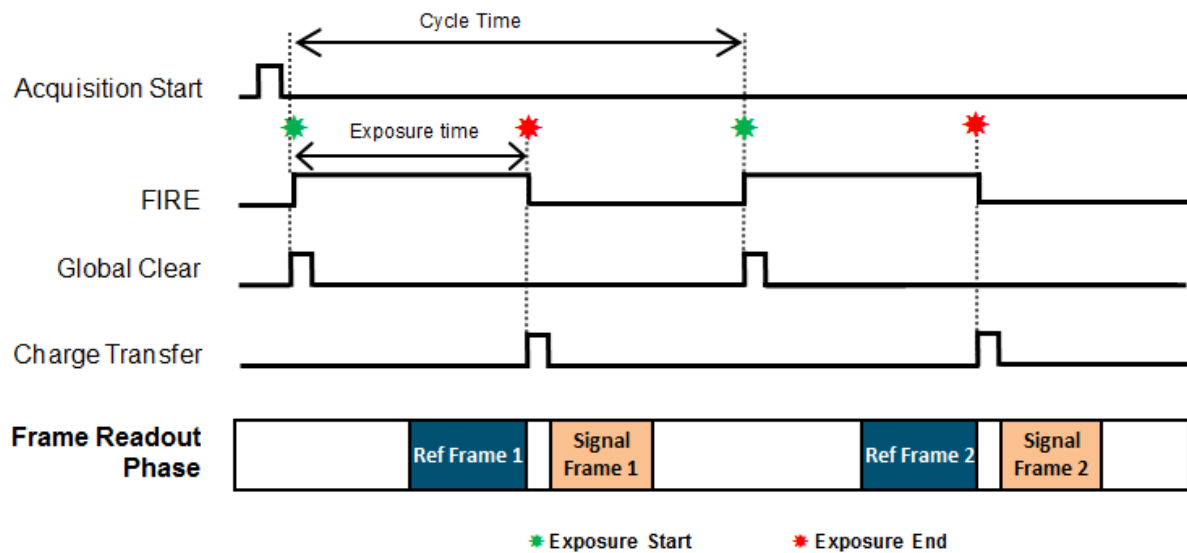

Figure 28: Global Shutter Internal Triggering – Short Exposures

Table 25: Global Shutter Internal Triggering - Short Exposures Timing Parameters

Parameter	Minimum	Maximum
Exposure	1 Row	1 Frame + 3 Rows
Cycle Time (1/Frame Rate)	Exposure + 2 Frames + 2 Inter-Frames	Exposure + 2 Frames + 2 Inter-Frames
Acquisition Start Delay	0	1 Frame

If the exposure time is greater than a frame read out time, the exposure starts first by pulsing the Global Clear. The reference frame is read out during the exposure such that the end of the reference read out is coincident with the end of the exposure. The Charge Transfer pulse then goes HIGH to transfer charge from all pixels in the sensor. Finally, the signal frame is then read as shown below.



**Figure 29:Global Shutter Internal Triggering – Long Exposures**

**Table 26:Global Shutter Internal Triggering - Long Exposures Timing Parameters**

Parameter	Minimum	Maximum
Exposure	1 Frame + 4 Rows	30 s
Cycle Time (1/Frame Rate)	Exposure + 1 Frames + 1 InterFrame + 6 Rows	20,000 s
Acquisition Start Delay	0	1 Row

## 5.11.16 Global Shutter Internal Triggering (Overlap Mode)

In Internal Triggering in Overlap Mode, the read out of an exposure overlaps with the next exposure. This allows the user to maximise the Cycle Time for a given exposure time. The absolute maximum frame rate achievable is the time taken to read out both the Reference and Signal Frame from the sensor. As in Non-Overlap Mode, the user has control over the exposure time and cycle time.

In this scenario, the exposure begins by pulsing the Global Clear. The reference frame is read out during the exposure such that the end of the reference read out is coincident with the end of the exposure. The Charge Transfer pulse then goes HIGH to transfer charge from all pixels in the sensor. The signal frame is then read out. During this read out, a new exposure begins by pulsing the Global Clear.

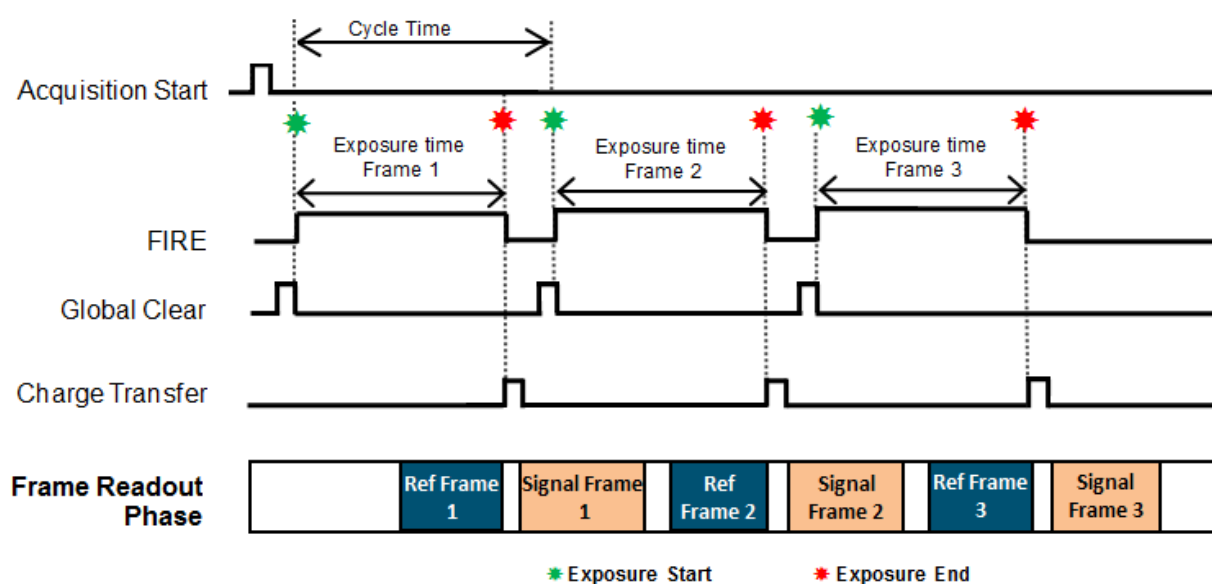

Figure 30: Global Shutter Internal Triggering (Overlap Mode)

Table 27: Global Shutter Internal Triggering (Overlap Mode) Timing Parameters - Cycle Time Dependency on Exposure

Parameter	Minimum	Maximum
Exposure	1 Frame + 1 InterFrame + 1 Row	2 Frames + 1 InterFrame
Cycle Time (1/Frame Rate)	2 Frames + 2 InterFrames + 1 Row	2 Frames + 2 InterFrames + 1 Row
Acquisition Start Delay	0	1 Row
Exposure	2 Frames + 1 InterFrame + 1 Row	30 s
Cycle Time (1/Frame Rate)	Exposure + 1 InterFrame + 1 Row	30 s
Acquisition Start Delay	0	1 Row

---

**Note**

The table shows that the cycle time depends on the exposure selected – within the exposure range detailed in the first row the cycle time is constant, however for exposures of (2 Frames + 1 Interframe + 1 Row) or longer the cycle time increases with exposure.

## 5.11.17 Global Shutter External or Software Triggering

In this section, both External and Software Trigger are described in the same diagram as the acquisition sequence is the same. The trigger event can either from the EXT input or sent via software. While waiting on the trigger event, the sensor is put into a “pre-scan read out cycle”. On detection of the trigger, the Global Clear line is pulsed to clear the charge from the sensor. The exposure period then starts and lasts for the user defined exposure time. The reference frame is read out during the exposure such that the end of the reference read out is coincident with the end of the exposure. The Charge Transfer pulse then goes HIGH to transfer charge from all pixels in the sensor. Finally, the signal frame is then read. The camera then returns to the “pre-scan read out cycle” awaiting for the next trigger.

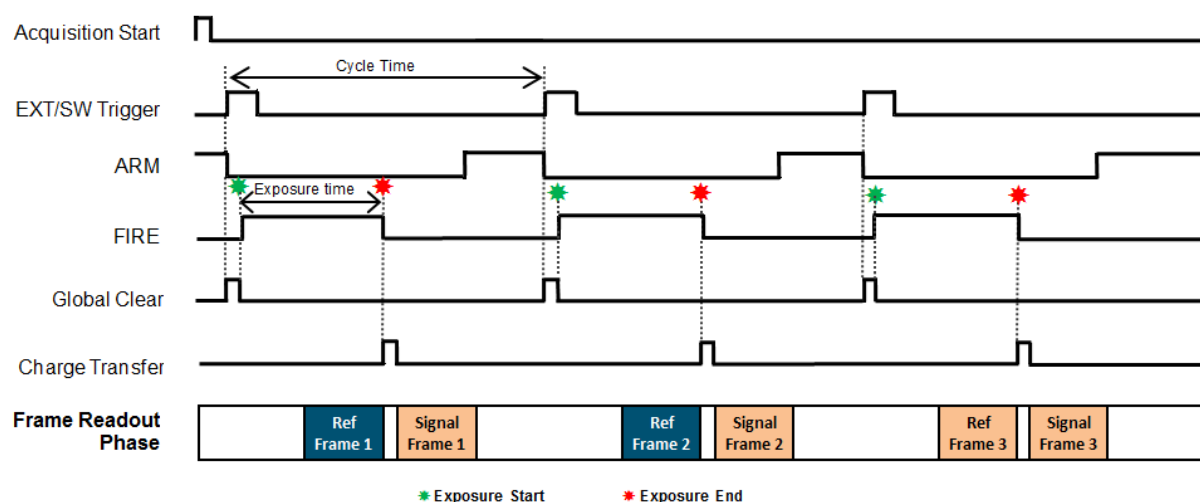

**Figure 31:Global Shutter External/Software Triggering (Non Overlap Mode)**

**Table 28:Global Shutter External/Software Triggering Timing Parameters (Non Overlap Mode)**

Parameter	Minimum	Maximum
Exposure	1 Frame + 4 Rows	30 s
Cycle Time (1/Frame Rate)	Exposure + 1 Frame + 1 InterFrame + 5 Rows	
Acquisition Start Delay	1 Row	2 Rows
EXT Trig Pulse Width	2 Sensor Speed Clock Cycles	

With overlap on "[Global Shutter External/Software Triggering \(Overlap Mode\)](#)" on the next page, the camera can accept a trigger to begin the next exposure prior to the signal frame readout completing. Note that external triggers will be missed if

it is too fast- refer to "Global Shutter External/Software Triggering Timing Parameters (Overlap On) - Cycle Time Dependent on Exposure" below for guidelines on time restrictions.

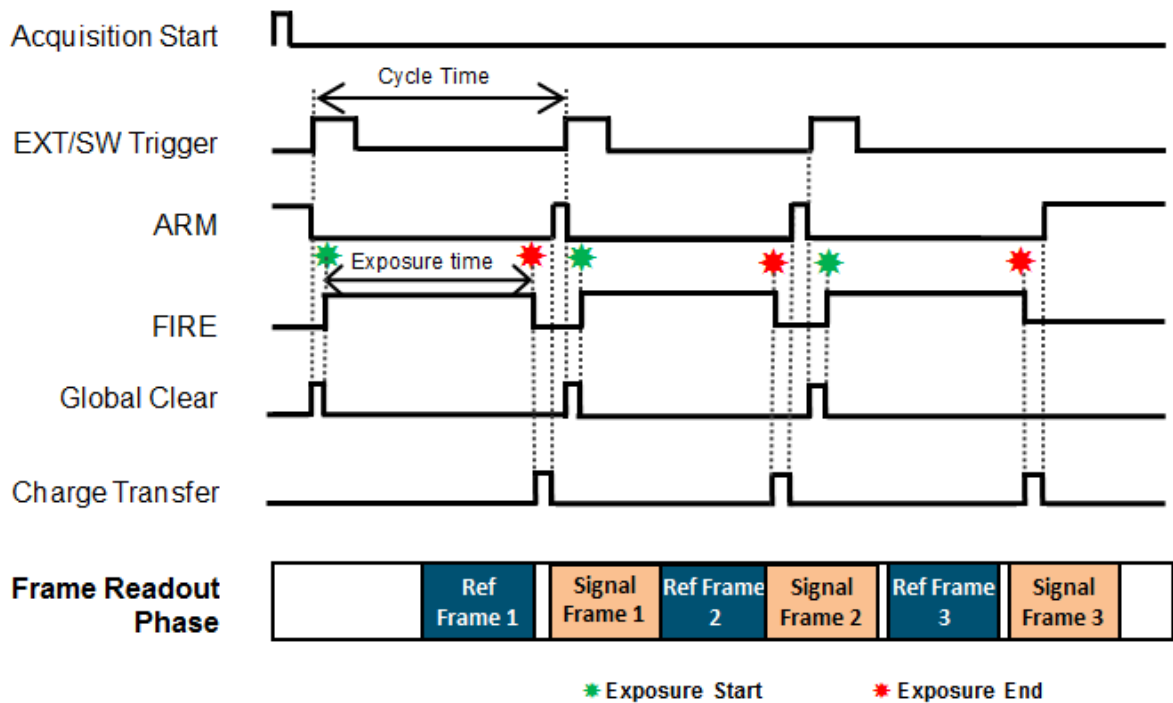

Figure 32:Global Shutter External/Software Triggering (Overlap Mode)

Table 29:Global Shutter External/Software Triggering Timing Parameters (Overlap On) - Cycle Time Dependent on Exposure

Parameter	Minimum	Maximum
Exposure	1 Frame + 1 InterFrame + 1 Row	2 Frames + 1 InterFrame + 4 Rows
Cycle Time (1/Frame Rate)	2 x (1 Frame + 1 InterFrame + 1 Row)	
External Start Delay	1 Row	2 Rows
EXT Trig Pulse Width	2 Sensor Speed Clock Cycles	-
Exposure	2 Frames + 1 InterFrame + 5 Rows	30 s
Cycle Time (1/Frame Rate)	Exposure + 1 InterFrame + 2 Rows	
External Start Delay	1 Row	2 Rows
EXT Trig Pulse Width	2 Sensor Speed Clock Cycles	-

## 5.11.18 Global Shutter External Exposure Triggering (Non-Overlap Mode)

While waiting on the trigger event, the sensor is put into a “pre-scan read out cycle”. On detection of the trigger event, the Global Clear is pulsed to clear the charge from the sensor. The exposure period then starts and lasts for the width of the External Trigger. During the exposure period, a reference frame is read immediately as the system has no method to know how long the External Trigger will be HIGH for. When the external trigger input goes LOW, the exposure ends by transferring the charge in all pixels simultaneously to the measurement node. A signal frame read out then begins. The period of the external trigger pulse defines the overall cycle time. If the width of the trigger event is less than the frame read out time, the falling edge will be missed and a subsequent falling edge will be required to end the exposure.

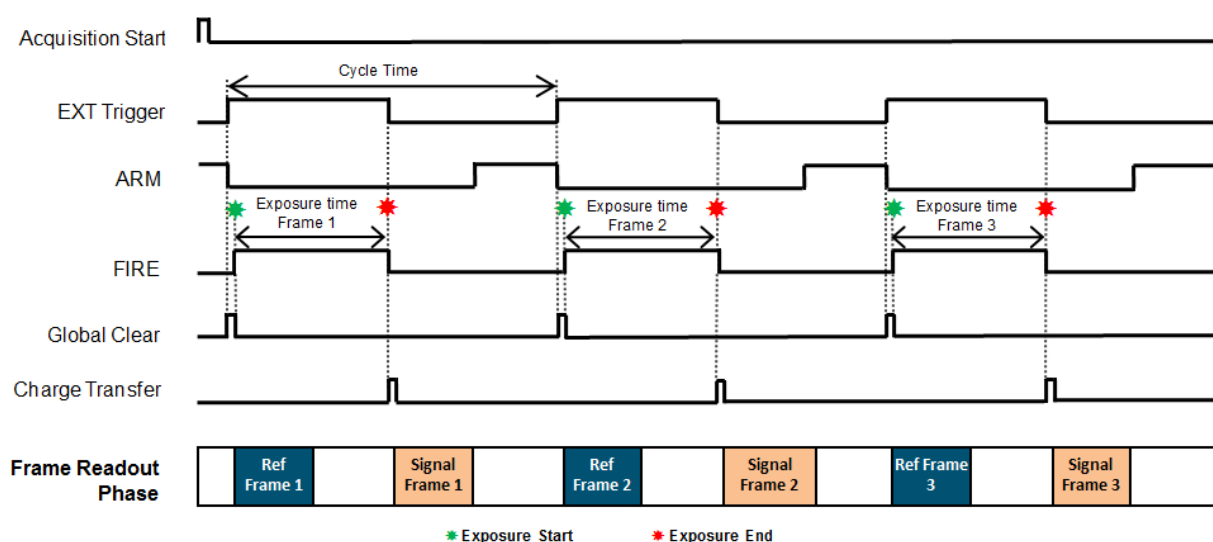

Figure 33: Global Shutter External Exposure Triggering (Non-Overlap Mode)

Table 30: Global Shutter External Exposure Triggering – Non Overlap Mode Timing Parameters

Parameter	Minimum	Maximum
Exposure (EXT Trig Pulse Width)	1 Frame + 3 Rows	30 s
Cycle Time ( EXT Trig Period)	EXT Trig Pulse Width + 1 Frame + 1 InterFrame + 6 Rows	
External Start Delay	1 Row	2 Rows
EXT Trig Pulse Width	1 Frame + 4 Rows	

---

### Note

The table shows that the cycle time depends on the exposure selected – within the exposure range detailed in the first row the cycle time is constant, however for exposures of (2 Frames + 1 Interframe + 5 Rows) or longer the cycle time increases with exposure.



### 5.11.19 Global Shutter External Exposure Triggering (Overlap Mode)

In overlap mode, every positive edge of an External trigger will trigger a signal frame read out and start a new exposure. The period of External trigger pulse defines both the exposure time and cycle time. Note that when an acquisition starts, the first positive edge of the trigger will initiate the first exposure but also output a frame that has an incorrect exposure which is therefore discarded. The next positive edge of the trigger will end the first exposure and start a new frame read out. From the figure below, it is can be seen that the minimum exposure time is approximately two frame read out periods. The first read out period is used to read out the “Signal” frame while the second is used to read out the “Reference” frame for the subsequent “Signal” frame.

If the period of the external trigger is less than the minimum period discussed above any positive edge occurring during the “Signal” and “Reference” frames will be ignored. The ARM signal indicates when positive going edges will be accepted.

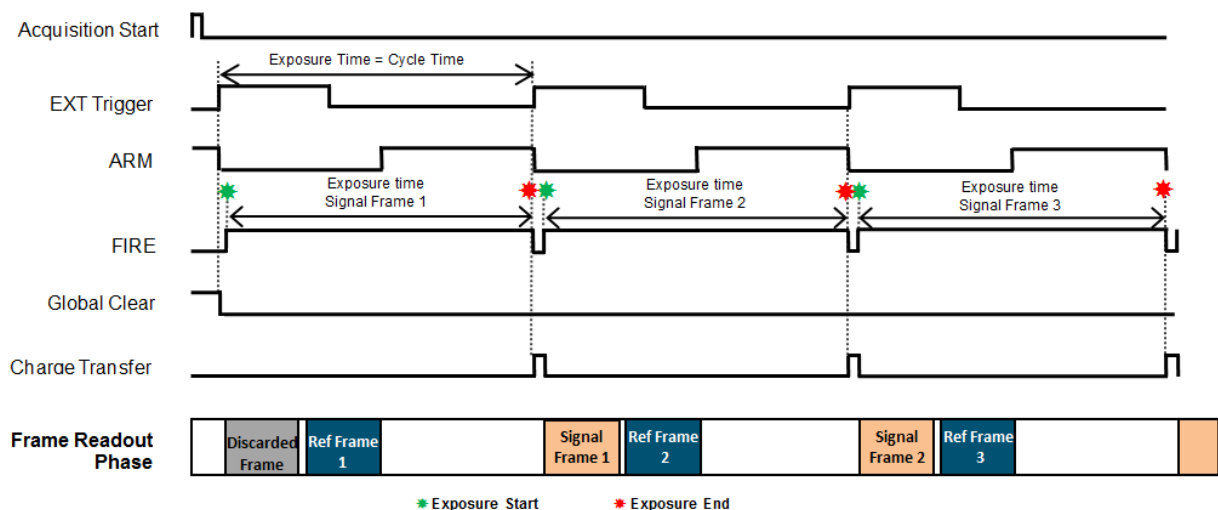

Figure 34:Global Shutter External Exposure Triggering (Overlap Mode)

Table 31:Global Shutter External Exposure (Overlap Mode) Timing Parameters

Parameter	Minimum	Maximum
Exposure (EXT Trig Pulse Width)	2 Frames + 2 InterFrames	30 s
Cycle Time ( EXT Trig Period)	2 Frames + 2 InterFrames	30 s
External Start Delay (1st Frame Only)	0	1 Row + Charge Transfer Time
External Start Delay (Frame #2... Frame	Charge Transfer Time	Charge Transfer Time

Parameter	Minimum	Maximum
#n)		
EXT Trig Pulse Width	2 Sensor Speed Clock Cycles	-

**Note**

In global shutter external exposure mode, taking exposures in darkness of 270 ms or more will lead to increased noise. A reference frame is taken at the start of the exposure and the camera then idles until the end is signalled, which triggers the image readout. The increased noise is coming from the separation of the reference frame and the image frame. This is less prominent with deeper cooling.

## 5.11.20 Global Shutter External Start Triggering

In this mode the camera will wait for a single external trigger event. Once this external trigger event is detected, the camera will progress as if the camera was in internal trigger mode. The ARM signal indicates to the user when the camera is ready to detect an External Start Trigger. The diagram below shows the External Start used in an Internal Trigger Non-Overlap Mode.

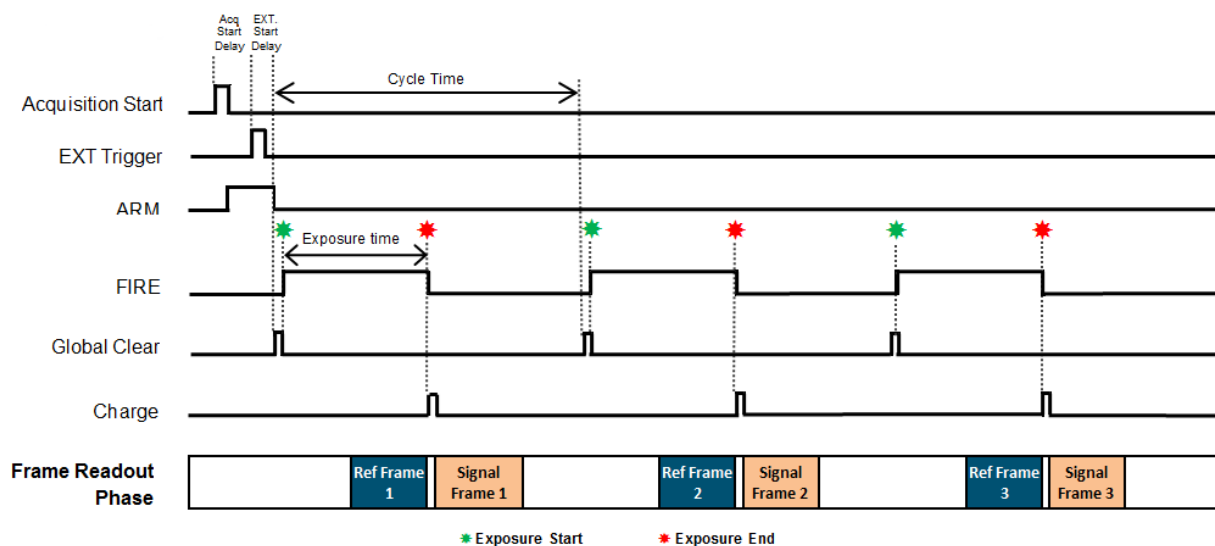

Figure 35:Global Shutter External Start Triggering

Table 32:Global Shutter External Start Triggering Timing Parameters (Overlap Off)

Parameter	Minimum	Maximum
Exposure	1 Row	1 Frame + 3 Rows
External Start Delay	0	1 Frame
EXT Trig Pulse Width	2 Sensor Clock Speed Cycles	
Exposure	1 Frame + 4 Rows	30 s
External Start Delay	1 Row	2 Rows
EXT Trig Pulse Width	2 Sensor Clock Speed Cycles	

Table 33:Global Shutter External Start Triggering Timing Parameters (Overlap On)

Parameter	Minimum	Maximum
Exposure	1 Frame + 1 InterFrame + 1 Row	30 s
External Start Delay	1 Row	2 Rows
EXT Trig Pulse Width	2 Sensor Clock Speed Cycles	

## 5.11.21 Global Shutter Triggering Constraints

The table below shows a summary of constraints when operating the ZL41 Cell 5.5 model in Global Shutter mode:

**Table 34: Global Shutter Mode Triggering Constraints**

Global Shutter Triggering Modes		Exposure Range	Max trigger jitter	Min trigger pulse width	Fast exposure switching supported
Internal (Non Overlap)	User settable exposure time and Cycle Time	Short Exp: 1 Row to (1 Frame + 3 Rows)	1 Frame	-	Yes
		Long Exp: (1 Frame + 4 Rows) to 30 s	1 Row		Yes
Internal Overlap (Overlap On)	User settable exposure time	(1 Frame + 1 InterFrame + 1 Row) to 30 s	1 Row	-	Yes
External/Software (Non Overlap)	User settable exposure Time. Cycle Time controlled via period of external trigger pulse	(1 Frame + 4 Rows) to 30 s	1 Row	2 Sensor Clocks	Yes
External/Software (Overlap On)	User settable exposure time. Cycle Time controlled via software trigger function	(1 Frame + 1 InterFrame + 1 Row) to 30 s	1 Row	2 Sensor Clocks	Yes
External Exposure (Non Overlap)	Exposure Time controlled by width of external trigger pulse. Cycle Time controlled via period of external trigger pulse.	(1 Frame + 3 Rows) to 30 s	1 Row	1 Frame + 3 Rows	No
External Exposure (Overlap On)	Exposure time controlled by period of +ve edge of external trigger pulses. Cycle Time is exposure time	(2 Frames + 2 InterFrames) to 30 s	1 Row	2 Sensor Clocks	No
External Start (Non Overlap)	User settable exposure time and Cycle Time but sequence initialized via external trigger pulse	Short Exp: 1 Row to (1 Frame + 3 Rows)	1 Frame	2 Sensor Clocks	Yes
		Long Exp: (1	1 Row		Yes

Global Shutter Triggering Modes		Exposure Range	Max trigger jitter	Min trigger pulse width	Fast exposure switching supported
		Frame + 4 Rows) to 30 s			
External Start (Overlap On)	User settable exposure time	(1 Frame + 1 InterFrame + 1 Row) + 30 s	1 Row	2 Sensor Clocks	Yes
<ol style="list-style-type: none"> <li>1. Exposure Time granularity for all modes is sensor row based so the exposure time in the dialog will always be rounded to the nearest integer number of row readout times.</li> <li>2. 1 Row is the time taken to perform a full row readout (2624 clock cycles), i.e. depends on readout rate.</li> <li>3. 1 Frame is the image height of a sensor half, defined in Rows and determined by the ROI configured, e.g. full frame = 1080. This is the number of rows that is read out by each sensor half. The frame readout time for any ROI can be requested via SDK function. (Refer to SDK3 User Guide for details).</li> <li>4. A short exposure is referred to an exposure that is less than a Frame Readout Time. (Depends on ROI selected).</li> <li>5. A long exposure is referred to an exposure time that is greater than a Frame Readout Time. (Depends on ROI selected).</li> <li>6. Image acquisition must be stopped to change between short and long exposures. Fast Exposure Switching can occur in the triggering modes shown above but the exposure time is then limited to the exposure range shown for each sequence.</li> </ol>					

---

## 5.12 Acquisition Modes

The following acquisition modes can be supported:

- Single Scan
- Kinetic Series
- Accumulate
- Run Till Abort

Notes
<p>The term 'User Frame', in this section refers to a single frame in Rolling Shutter mode and a reference/image frame pair in Global Shutter mode.</p> <p>The term 'valid trigger' refers to a trigger that is applied when the camera is ready to accept it.</p>

---

### 5.12.1 Single Scan

**Single Scan** refers to an acquisition in which only one user frame is transmitted from the camera.

A user frame is output from the sensor on receipt of a valid trigger of the selected type and then transmitted from the camera. Note that any subsequent triggers within the same acquisition are ignored.

---

### 5.12.2 Kinetic Series

Kinetic Series refers to an acquisition in which a finite number of user frames are transmitted from the camera. The number of frames in a Kinetic Series is defined by the user. One user frame is output from the sensor on receipt of each valid trigger of the selected type. Valid triggers continue to output user frames from the sensor until the defined number of user frames has been reached. Frames are transmitted from the camera, depending upon the connectivity i.e. 3-tap or 10-tap Camera Link. Note that after the required number of valid triggers has been received, any subsequent triggers within the same acquisition are ignored.



---

### 5.12.3 Accumulate

Accumulate refers to an acquisition in which a number of frames in a series are accumulated together into a single image. This accumulation of user frames is performed off-camera. Either all the user frames in a series are accumulated to give a single accumulated image or a smaller number of user frames in the series are accumulated to give a series of accumulated images.

---

#### 5.12.4 Run Till Abort Acquisition

Run Till Abort refers to an acquisition in which an infinite number of user frames can be transmitted from the camera and the acquisition will continue to run until it is aborted.

One user frame will be output from the sensor on receipt of each valid trigger of the selected type. All valid triggers will output another user frame from the sensor. Frames are transmitted from the camera in as quick succession as possible.

---

### 5.12.5 Live Mode

Live Mode refers to a version of Run Till Abort in which each user frame will be the latest frame output by the sensor and will have the minimum amount of latency through the camera as possible.

Live mode requires the use of SW Trigger. In order to ensure that frames are buffered in the on-camera memory for the shortest possible time, the next SW trigger must not be sent until the user frame has been transmitted from the camera. This ensures that the on-camera memory only stores a single user frame at a time and no additional latency builds up.

#### Note

**The frame rate achievable in Live Mode is dependent on the performance of the system that the camera is attached to.**

---

### 5.12.6 Fast Exposure Switch

During an acquisition the user can change the exposure time, within allowable limits. Once a new exposure value has been written, it will be applied to the next user frame after the current frame exposure has completed. The exposure time can be changed any number of times before the acquisition finishes.

---

### 5.12.7 Frame Rate Control

If Internal Trigger is being used, the camera will trigger the sensor at the fastest possible rate by default. The user can reduce this trigger rate by defining a Frame Rate that is less than the maximum possible rate. Frame Rate must be set before the acquisition starts.

Note
<b>This is currently only applicable to 'long exposures'.</b>

---

## 5.12.8 LightScan PLUS

### 5.12.8.1 Multiple Readout Directions

The standard mode of operation in sCMOS cameras is to read out from the centre of the sensor out to the edge with two halves of the sensor exposing simultaneously. LightScan PLUS provides the user with a range of different rolling shutter readout options. Firstly, the rolling shutter can now be scanned from the top to the bottom of the sensor or vice versa in one continuous sweep (Figure 34), adapting the sensor to single port readout. It should be acknowledged however that this functionality will halve the rolling shutter frame rate, resulting in a maximum full resolution frame rate of 50 fps.

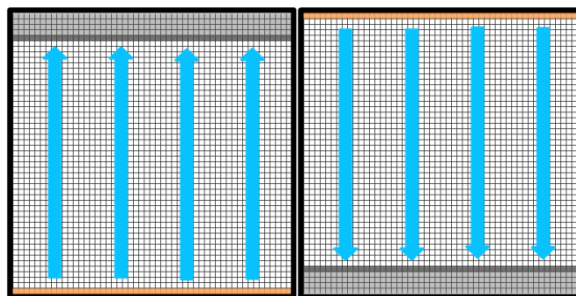

**Figure 36:**LightScan PLUS enables the rolling shutter to scan the sensor from top to bottom or vice versa in one continuous sweep. This is also known as Single Port Readout.

Furthermore, LightScan PLUS offers the user multiple new scanning directions for the rolling shutter mechanism in which both sides of the sensor can be used simultaneously, synchronized to two scanning lasers, thus providing the option to utilize the full 'Dual Port Readout' capability of the sensor and provide 100 fps full resolution frame rate. These new scanning options for sCMOS are also ideal for dual-wavelength applications where two light sources are scanning across the image sensor with different wavelengths. The multi-laser readout configurations are illustrated below.

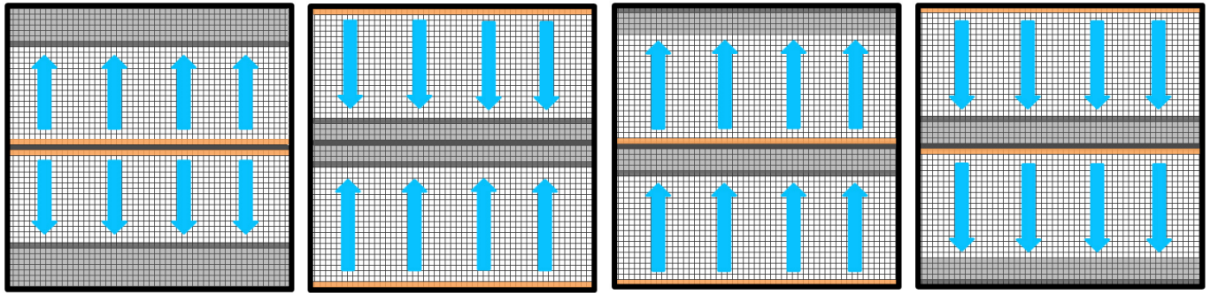

**Figure 37: Multiple 'dual laser' scanning options available. The standard rolling shutter scan mode (Centre outwards in both directions simultaneously) is illustrated on the left along with the three additional scanning options.**

For each of the various scanning options outlined above, CycleMax - a feature of LightScan PLUS – ensures minimum dead time between scans by enabling the laser sweep and corresponding rolling shutter scan direction to alternate from top-bottom to bottom-top, therefore avoiding the need to reset the laser for each subsequent image. Furthermore, a programmable trigger delay has been built into LightScan Plus enabling the user to input a defined delay time between the camera receiving an external trigger and the acquisition start. This is important when using peripheral devices e.g. controlling the illumination source

### 5.12.8.2 FlexiScan

Flexiscan functionality allows the user to optimize between the conflicting parameters of confocality (Exposure Window Height), frame rate (Line Scan Speed dependent) and exposure. A logical way to think about this is; set the Exposure Window Height to achieve the degree of confocality (fewer rows gives more background haze removal), next set the Line Scan Speed to achieve an exposure time that allows you to get a good enough signal strength to see what you intend to measure, and finally synchronize the optical scanner speed to this resultant readout.

**Table 35: Global Range of Line Scan Speeds available through FlexiScan for each pixel readout rate. Also shown is the resultant range of scan times for one full image (full top to bottom or bottom to top sweep) and the resultant exposure range, assuming a 'slit width' of 10 rows.**

Parameter	*216 MHz	*540 MHz
Line scan speed range (rows/ms)	2.98 - 41.67	7.43 - 104
Resultant scan time for one full image (ms)	49 - 686	19.69 - 275.66
Resultant exposure range for slit width of 10 rows (ms)	0.240 - 3.36	0.096 - 1.344

---

Users are advised not to input a value for line scan speed referring to a pre-selected scanning speed of the illumination light, but to adjust the scanning speed of the illumination for the synchronization instead.



---

## Section 6 - Maintenance

### Caution

**There are no user-servicable parts inside the camera. Damage caused by unauthorised maintenance or procedures will invalidate the warranty.**

---

## 6.1 Regular Checks

- The state of the product should be checked regularly, especially the integrity of the External Power Supply and the mains cable.
- Ensure that the AC mains plug in connection to building power outlet remains readily accessible to facilitate disconnection from the power supply.
- Do not use equipment that is damaged.

---

## 6.2 General Cleaning & Decontamination Information

- The product body can be cleaned with a soft cloth and dampened by water or glass cleaner.
- Never spray liquids directly on the product; apply cleaning solution to the cloth, then wipe the product body with the dampened cloth.
- Do not use abrasive or other detergents to clean the product.
- Decontamination: In the event any product must be returned the customer must complete a decontamination form to declare the equipment is contamination free and safe for Andor employees to work on:  
[andor.oxinst.com/rma](https://andor.oxinst.com/rma)

---

## 6.3 Fuse Replacement

In the U.K., Ireland and some other countries, the supplied mains cable has a BS 1363/A (also known as ITA Type G) plug that includes an integrated fuse. Only replace with fuse of the same type and rating for continued protection. The characteristics of a replacement fuse are as follows:

- **Rating:** 5 A, 240 VAC
- **Type:** BS 1362, size:  $\frac{1}{4} \times 1$ " (6.3 × 25.4 mm) cartridge

---

## 6.4 Annual Electrical Safety Checks

- It is advisable to check the integrity of the insulation and protective earth of the product on an annual basis, e.g. U.K. PAT testing. However over time the repetition of dielectric strength tests can damage safety insulation.
- Do not use equipment that is damaged.

---

## 6.5 Cleaning the Camera Window

At some point, it may become necessary to clean debris that may have settled on the sCMOS imaging sensor window. Cleaning the camera window can provide effective results providing you carefully follow these step-by-step directions.

### Caution

**Only open the shutter (if present) using camera control software.**

**Do not attempt to manually open the shutter (if fitted) with your fingers or other objects.**

**Scratching the window may require the window to be replaced which is not covered under the product warranty**

**Cleaning the window is done entirely at the customers risk, window replacement is not covered under the warranty. It's better to under-clean than to over-clean.**

### Tools Required

- Compressed Air Can (or source of clean compressed air)
- Optics Brush

### Window Cleaning Procedure

1. Remove the camera from your microscope (or other optical equipment) and place it on a clean dry surface.
2. Use the camera control software to open the shutter (if fitted).

If your program does not have this feature, try starting a long exposure. Over exposing the sensor to room light will not damage the sensor.

### Guidelines for using Compressed Air

If you are using a compressed air can always test-blast away from window before blowing air on the window. When you test-blast, you'll notice a spray of condensation shoot out from the can.

- If condensation does form on the window, do not wipe it off. Allow it to fully dry before proceeding.
- Always orient the compressed air can in an upright position before spraying.

- 
- A clean source of compressed air such as an air can is recommended- do not use a compressor that may spray fine droplets of oil, or an unfiltered air supply that may spray dust particles onto the camera window.
3. With the shutter (if present) open, turn the camera on its side making it easier for particles to fall out of the camera head face the window toward you at the edge of a table.
  4. Give the window short blasts of compressed air to work dust particles out of the camera head.
  5. If there are still particles stuck on the window use an optics brush to very carefully dislodge them from the window surface. Then spray the dust particles out of the camera head with compressed air.
  6. Make sure to use compressed air to clean your adapter tubes and focal reducers as well so you don't get more dust once everything's assembled.

---

## 6.6 Cooling Hoses and Connections

The user should routinely check all coolant hoses and connections for signs of leakage, damage or wear. All seals must be intact before powering on camera system and any worn / damaged items must be replaced immediately.



## Section 7 - Troubleshooting

Fault	Cause	Solution
Camera buzzer does not sound on start-up	The camera buzzer should be audible momentarily when the camera is switched on.	If this does not occur, ensure that power is connected to the camera and the On/Off switch is set to On
Camera is not recognized by PC		<ul style="list-style-type: none"> <li>• Ensure the camera is switched on</li> <li>• Check the Camera to PC connection. For Camera Link models, check that the cable is connected between the CL1 connector position and the PCIe card in the PC. (For 10-tap variants, check that the CL2 cable is connected). For USB 3.0 models, check that USB 3.0 cable is connected between the camera and the USB 3.0 slot on the PC.</li> <li>• Check that the frame grabber card and drivers have been correctly installed (see "<a href="#">Connecting the Camera to the PC</a>" on page 39)</li> </ul>
Buzzer sounds continuously	This indicates that an "over temperature" condition has occurred within the camera.	<ol style="list-style-type: none"> <li>1. Power the camera off and allow it to cool down</li> <li>2. For air-cooled models, ensure fan vents are not obstructed For water-cooled models, ensure that water coolant supply is connected and that chiller/re-circulator is operational</li> <li>3. Check the camera is operating within the specified environmental conditions (see "<a href="#">Technical Specifications</a>" on page 140)</li> </ol>
Fan not operating as expected		<ul style="list-style-type: none"> <li>• To protect the internal electronics, the fan defaults to full speed if the camera heat-sink temperature exceeds 50°C.</li> <li>• The fan will continue to run even if the user has switched it off via software, until the correct heatsink temperature has been reached.</li> </ul>

Fault	Cause	Solution
Camera does not cool to the required temperature		<ul style="list-style-type: none"> <li>• Check that the operating ambient temperature is within allowable limits (see <a href="#">"Technical Specifications" on page 140</a>) when cooling the sensor to 0°C.</li> <li>• Check that the camera vents are not blocked and have sufficient clearance to allow air flow.</li> <li>• Check that the fan is switched on (or for water cooled models, the coolant system is operating correctly).</li> </ul>
Fire, Aux_Out and Arm outputs not functioning correctly		These are 5 V TTL outputs which should not be used to drive low impedance loads. Please refer to Section <a href="#">"Multi I/O Timing Cable Pin Outs" on page 21</a> and <a href="#">"Impedance Information" on page 23</a> for suggested terminations
External Trigger input not functioning correctly		This is a 5 V TTL input which should be driven from a 5 V TTL compatible source. Please refer to Section <a href="#">"Multi I/O Timing Cable Pin Outs" on page 21</a> and <a href="#">"Impedance Information" on page 23</a> for further details.
Condensation Appearing On Exterior Of Camera	<p>NEVER USE WATER THAT HAS BEEN CHILLED BELOW THE DEW POINT OF THE AMBIENT ENVIRONMENT TO COOL THE CAMERA.</p> <p>You may see condensation on the outside of the camera body if the cooling water is at too low a temperature or if the water flow is too high. The first signs of condensation will usually be visible around the connectors where the water tubes are attached.</p>	<ol style="list-style-type: none"> <li>1. Switch off the system</li> <li>2. Wipe the camera with a soft, dry cloth. It is likely there will already be condensation on the cooling block and cooling fins inside the camera.</li> <li>3. Set the camera aside to dry for several hours before you attempt reuse.</li> <li>4. Before reuse blow dry gas through the cooling slits on the side of the camera to remove any residual moisture. Use warmer water or reduce the flow of water when you start using the device again.</li> </ol> <p>This is not an issue when using a Re-circulator which eliminates the dew point problem. Refer to <a href="#">"Dew Point Graph" on page 150</a></p>

---

## Appendix

The following sections contain information on product specifications, including technical, environmental, mechanical and electrical specifications. In addition, detailed mechanical drawings are presented.

# Appendix A: Technical Specifications

## Model Specific Specifications<sup>•1</sup>

Model	ZL41 Cell 5.5		ZL41 Cell 4.2		
Sensor type	Front Illuminated Scientific CMOS				
Active pixels (W x H)	2560 x 2160 (5.5 Megapixel)		2048 x 2048 (4.2 Megapixel)		
Sensor size	16.6 x 14.0 mm 21.8 mm diagonal		13.3 x 13.3 mm 18.8 mm diagonal		
Pixel readout rate (MHz)	200 (100 MHz x 2 sensor halves) 560 (280 MHz x 2 sensor halves)		Slow Read 216 (108 MHz x 2 sensor halves) Fast Read 540 (270 MHz x 2 sensor halves)		
Read noise (e-) Median [rms] •2		Rolling Shutter	Global Shutter		Rolling Shutter
	@ 200 MHz	0.9 [1.2]	2.3 [2.5]	@ 216 MHz	0.90 [1.1]
	@ 560 MHz	1.2 [1.6]	2.4 [2.6]	@ 540 MHz	1.10 [1.3]
Maximum Quantum Efficiency •3	64%		82%		
Sensor Operating Temperature	0°C (up to 30°C ambient)* Air cooled -10°C** Water cooled		0°C (up to 27°C ambient) -10°C**		
Dark current, e-/pixel/sec	0.10				

Model	ZL41 Cell 5.5	ZL41 Cell 4.2
@ min temp •4		
Air cooled	0.019	
Water cooled		
Readout modes	Rolling Shutter and True Global Shutter (Snapshot)	Rolling Shutter and Global Clear •7
Maximum dynamic range	33,000:1	
Photon Response Non-Uniformity (PRNU)	< 0.01%	
Half-light range	< 0.1%	
Low light range		
Pre-defined Region of Interest (ROI)	2048 x 2048, 1920 x 1080, 1392 x 1040, 512 x 512, 128 x 128	1920 x 1080, 1392 x 1040, 512 x 512, 128 x 128
User defined ROI (granularity)	Yes (1 pixel) ***	
Data range	12-bit (fastest USB 3.0 speeds) and 16-bit (maximum dynamic range)	
Interface options	USB 3.0•8 Camera Link 10-tap	
<p>* Max ambient for ZL41 Cell 5.5 aircooled models manufactured prior to Feb 2015 is 35°C</p> <p>** Cooling temperature must be above the dew point</p> <p>*** Minimum ROI size: 4 x 8 (W x H) possible for 12- or 16-bit modes and for both Camera Link 10-tap and USB 3.0 models</p>		

## General Specifications•1

Pixel size (W x H)	6.5 µm
Pixel well depth (e-)	30,000
Linearity (% , maximum)•5	

Full light range	Better than 99.8%
Low light range (< 1000 electrons signal)	Better than 99.9%
MTF (Nyquist @ 555 nm)	45%
Pixel binning	Hardware binning: 2 x 2, 3 x 3, 4 x 4, 8 x 8
Anti-blooming factor	x 10,000
I/O	External Trigger, Fire, Fire n, Fire All, Fire Any, Arm
Trigger Modes	Internal, External, External Start, External Exposure, Software Trigger
Software Exposure Events* <sup>6</sup>	Start exposure - End exposure (row 1), Start exposure - End exposure (row n)
Hardware timestamp accuracy	25 ns
Internal memory	1 GB

### Footnotes

1. Figures are typical unless otherwise stated.
2. Readout noise is for the entire system and is taken as a median over the sensor area excluding any regions of blemishes. It is a combination of sensor readout noise and A/D noise.
3. Quantum efficiency of the sensor at 20°C as supplied by the manufacturer.
4. Dark current measurement is taken as a median over the sensor area excluding any regions of blemishes.
5. Linearity is measured from a plot of Signal vs. Exposure Time, in accord with EMVA 1288 standard.
6. Software Exposure Events provide rapid software notification (SDK only) of the start and end of acquisition, useful for tight synchronization to moving peripheral devices e.g. Z-stage.
7. 'Global Clear' is an optional keep clean mechanism that can be implemented in rolling shutter mode, which purges charge from all rows of the sensor simultaneously, at the exposure start. The exposure end is still rolling shutter. It can be used alongside the Fire All output of the camera and a pulsed light source to simulate Global Exposure mechanism, albeit less efficiently than the true Global Shutter exposure mode of ZL41 Cell 5.5. Furthermore Global Clear differs from true Global Shutter in that it can only

---

be used in 'non-overlap' readout mode, i.e. sequential exposure and readout phases rather than simultaneous.

8. ZL41 Cell USB 3.0 models should work with any modern USB 3.0 enabled PC/laptop (provided hard drives or RAM is sufficient to support data rates) as every USB 3.0 port should have its own host controller. ZL41 Cell USB 3.0 models also ship with a USB 3.0 PCI card as a means to add a USB 3.0 port to an older PC, or as a diagnostic aid to interoperability issues or to ensure maximum speed.

---

## Environmental Specifications

Location to be used	Indoor use only
Altitude	Up to 2000 m
Operating temperature	0°C to 30°C ambient (ZL41 Cell 5.5) 0°C to 27°C ambient (ZL41 Cell 4.2)
Storage temperature	-10°C to 50°C
Operating relative humidity	<70% (non-condensing)
Pollution degree	Pollution degree 2. Normally only non-conductive pollution occurs. Occasionally, however, a temporary conductivity caused by condensation must be expected.
Cooling vent clearance	Do not cover during operation. Allow 100 mm clearance at air vents.



---

## Mechanical Specifications

ZL41 Cell	
Weight (ZL41 Cell unit only)	1 kg
Weight (External Power Supply)	0.33 kg
Dimensions	See Mechanical Drawings

---

## Power Supply Information

### Electrical Power Specifications

	ZL41 Cell
Mains Input for Supplied External Power Supply	100 – 240 VAC, 50 – 60 Hz
Power Consumption	Camera + External Power Supply: 30 W typical/ 56 W max Camera Only: 25 W typical/ 50 W max
Voltage Rating	12 V
Current Rating	5 A
Mains Over-voltage Category	CAT II. An overvoltage category of CAT II means that the equipment is designed to cope with transient voltages above the rated supply that would be experienced by any product connected to a standard single-phase mains socket in a building.

## External Power Supply Specifications

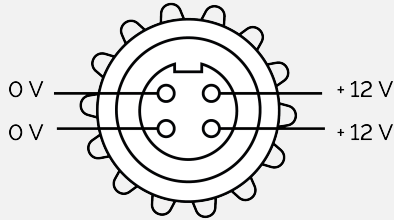
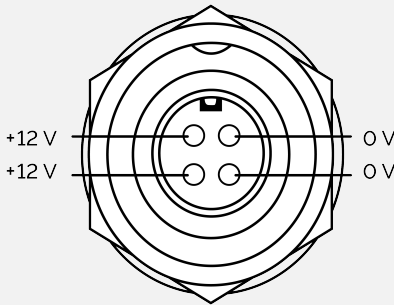
	ZL41 Cell
Supplied EPS	Andor PS-12
Low Voltage Supply Input	12 V +/- 5%
Low Voltage Supply Current	5 A
Low Voltage Supply Cable Plug	Tyco Electronics 3-1437719-3
Low Voltage Supply Cable Plug Insertion View	
Low Voltage Supply Pin Connections	Pins 1 & 2: 0 V Pins 3 & 4: 12 V Shield: Unconnected
Functional Earth for EMC	0 V is connected to Mains Earth
Low Voltage Supply Product Socket	Tyco Electronics 6-1437719-4
Low Voltage Supply Product Socket Insertion view	
Ripple	200 mV peak-to-peak
In-rush Current Capability	Shall start up a load whose in-rush current from a 0.1 Ω source resistance is 1.7 A min. peak and a pulse width of 10 ms min. measured at half the peak
Safety	Certified to IEC 62368-1 in accordance with local safety regulations and meets the reinforced insulation from mains requirement of IEC 61010-1
Environmental	Ensure that the EPS meets the environmental specification of the overall product
EMC Ferrite	Fitted

# Appendix B: Mechanical Drawings

## Air Cooled Models

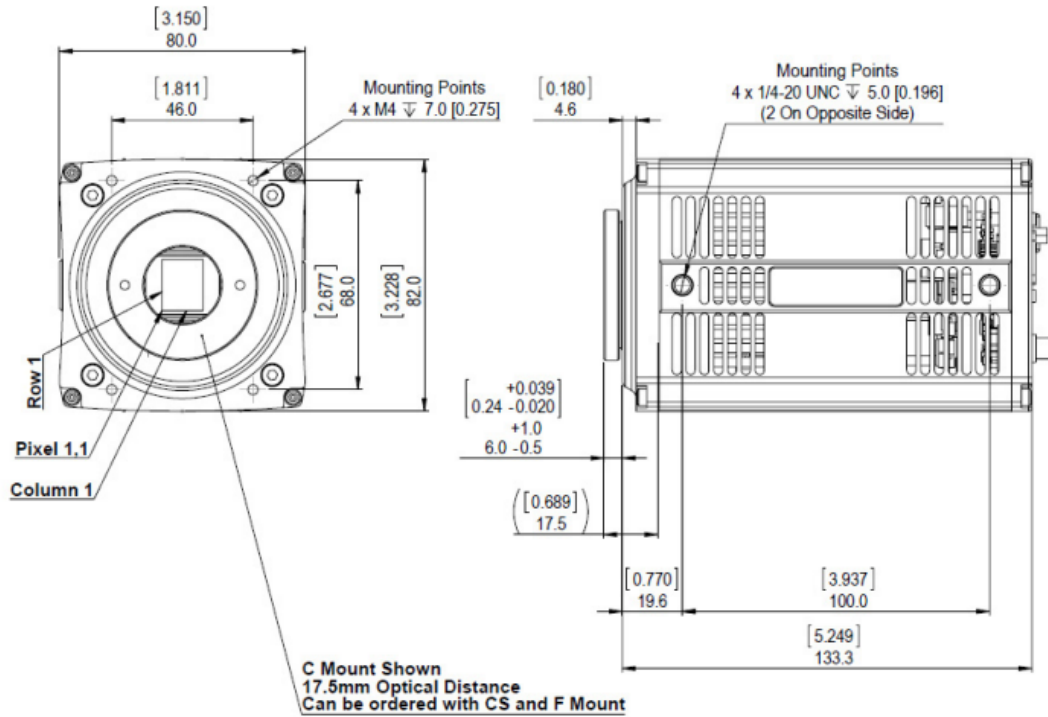

Zyla 5.5 3-tap version

Zyla 5.5 and Zyla 4.2 10-tap

Zyla 5.5 and 4.2 USB 3

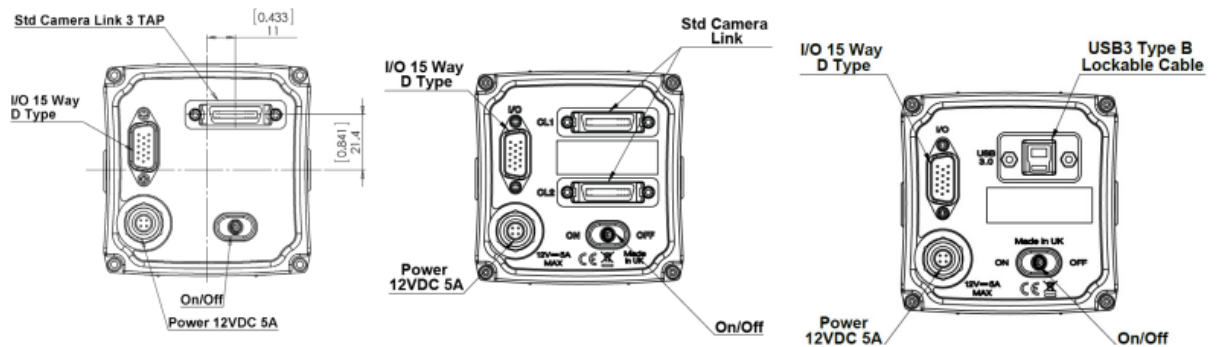

# Water Cooled Models

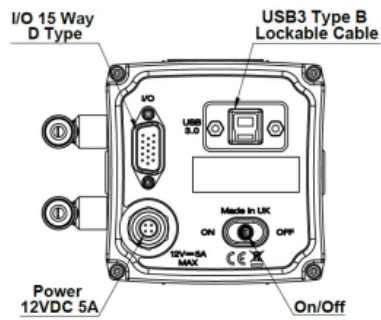
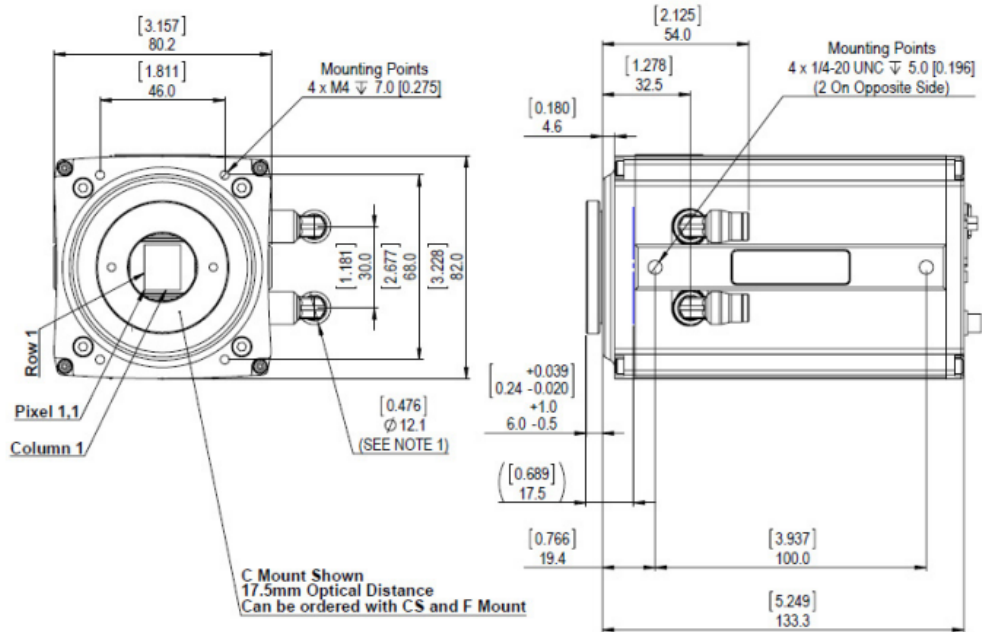

## Appendix C: Dew Point Graph

To avoid issues with condensation, the coolant temperature must be set above the dewpoint- the temperature at which condensation (dew) will form. In the relatively dry conditions of an air conditioned lab, or a cool dry climate, use of a coolant temperature of 10°C should not cause any problems. As relative humidity or ambient temperature increase however, the dewpoint temperature will also increase so that the minimum coolant temperature that can be used will have to increase accordingly. This will therefore limit the maximum cooling performance that can be achieved.

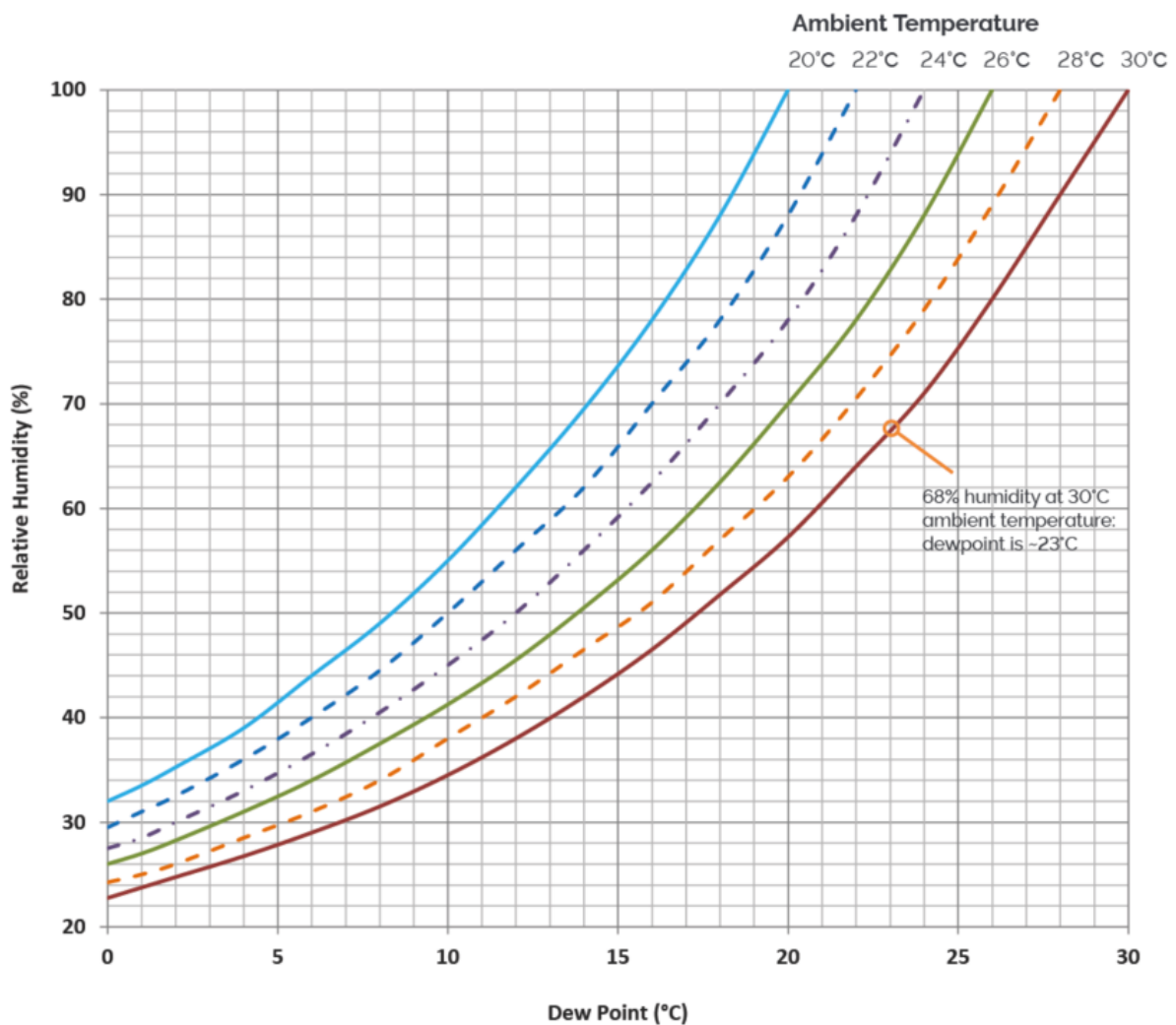

---

## Appendix D: Other Information

### Terms and Conditions of Sale and Warranty Information

The terms and conditions of sale, including warranty conditions, will have been made available during the ordering process. The current version for the US is [available here](#), for all other regions (except Japan) please [click here](#).

### EU/UK REACH Regulation Statement

Andor's EU/UK REACH Regulation statement is available at the [following link](#).

### Waste Electronic and Electrical Equipment

The company's statement on the disposal of WEEE can be found in the Terms and Conditions.



## Appendix E: China RoHS Hazardous Substances Declaration

Hazardous Substance: 有害物质						
Component Name 部件名称	Lead (Pb) 铅	Mercury (Hg) 汞	Cadmium (Cd) 镉	Chromium VI Compounds (Cr6+)	Polybrominated Biphenyls (PBB)	Diphenyl Ethers (PBDE)
Printed Circuit Board Assembly (FPGA (U14), Surface-mount Resistors and Capacitors, and Brass Connectors) 电路板组件 (FPGA (U14), 表面贴装电阻器和电容器, 以及黄铜连接器)	X	○	○	○	○	○
Hex Stand-offs (see image in table below) 六角隔撑	X	○	○	○	○	○
Screw Locks (see image in table below) 螺丝锁定	X	○	○	○	○	○
PS-12 External Power Supply (TT Electronics SW3605) Plug PS-12 外接电源 (TT Electronics SW3605) 插头	X	○	○	○	○	○
D.C. Power Socket on USB Board USB 板上的直流电源插座	X	○	○	○	○	○
All other parts 其余配件	○	○	○	○	○	○

This table was developed according to the provisions of SJ/T 11364

本表格依据 SJ/T 11364 的规定编制



O - The content of such a hazardous substance in all homogeneous materials of such a component is below the limit required by GB/T 26572

表示该有害物质在该部件所有均质材料中的含量均在O-表示该有害物质在该部件所有均质材料中的含量均在GB/T 26572规定的限量要求以下

X - The content of such a hazardous substance in a certain homogeneous material of such a component is above the limit required by GB/T 26572

X - 表示该有害物质至少在该部件的某一均质材料中的含量超出GB/T 26572规定的限量要求

Component Name 部件名称	
Hex Stand-offs 六角隔撑	 A vertical hexagonal metal stand-off with a threaded top.
Screw Locks 螺丝锁定	 A hexagonal metal screw lock with a threaded end.
PS-12 External Power Supply (TT Electronics SW3605) Plug PS-12 外接电源 (TT Electronics SW3605) 插头	 A cylindrical metal plug with a blue cap and a four-pin connector.

Component Name 部件名称	
<p>D.C. Power Socket on USB Board</p> <p>USB 板上的直流电源插座</p>	