

Andor **iKon** Series

Ultra-low dark current &
superb photon collection

Astronomy | X-ray Tomography | Neutron Radiography
Bioluminescence | *In vivo* Imaging | Plant Imaging

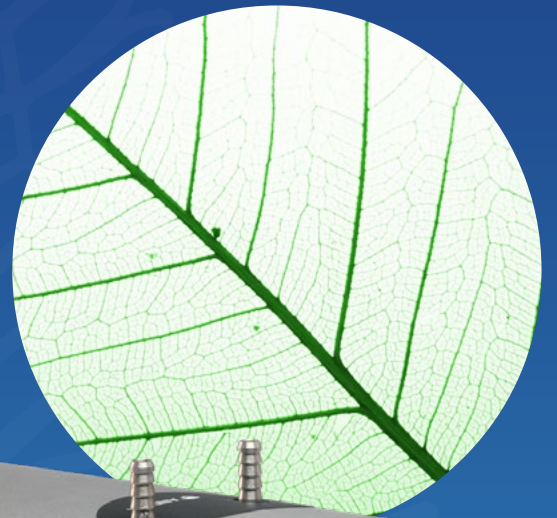
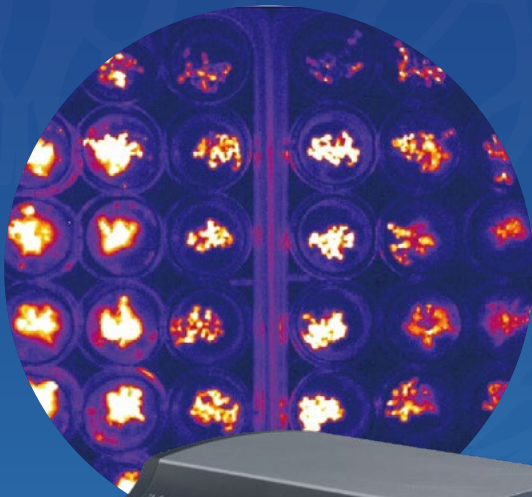

Introducing the iKon series

Industry-leading ultra-sensitive imaging technology

The iKon camera platform combines high-sensitivity sensors with deep cooling and permanent vacuum technology to achieve outstanding detection of ultra-low-level signals in long-exposure applications such as luminescence and astronomy.



iKon-L

Andor's iKon-L 936 is designed with scientific imaging in mind. The 2048 x 2048 array and 13.5 μm pixel pitch combine to deliver a 27.6 x 27.6 mm active image area, TE cooled down to -100°C. The iKon-L offers outstanding resolution, field of view, sensitivity and dynamic range performance. Ultimate sensitivity performance is achieved through combination of > 90% QE (back-illuminated sensor), low noise readout electronics and exceptionally deep TE cooling. The Dual AR deep depletion 'BEX2-DD' sensor option provides an unmatched QE profile, offering highest possible QE from UV through to NIR.

iKon-M

Andor's iKon-M 934 series cameras are designed to offer the ultimate in high-sensitivity, low noise performance, ideal for demanding imaging applications. These high resolution 1024 x 1024 CCD cameras boast up to 95% QE_{max} high dynamic range, 13 μm pixels and exceptionally low readout noise. The iKon-M benefits from negligible dark current with industry-leading thermoelectric cooling down to -100°C.

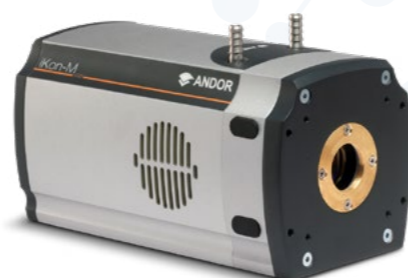

The 'Deep Depletion' sensor option offers ultimate performance for NIR applications, the Dual AR coating extends the QE performance significantly across the UV/visible region of the spectrum for the broadest possible spectral coverage from one sensor. Fringe Suppression Technology™ radically minimises etaloning effects in the NIR. Rapid vertical shifts combined with fast kinetics acquisition mode, comprehensive trigger modes and custom coated wedge window options, render the deep Depletion models ideal for NIR optimised Bose Einstein Condensation applications.

FEATURES AND BENEFITS

Andor iKon Series Common Features	
TE cooling to -100°C	Critical for elimination of dark current and maximising detection
USB connection	Simple plug & play connection
Integrated in EPICS	Platform is fully integrated into the EPICS control software
UltraVac™ ¹	Permanent vacuum seal technology. Industry leading cooling and QE performance, year after year
Windows, Linux, Labview & Python	Andor's user-friendly SDK supports both Windows and Linux OS and modern programming languages such as Python
Ultra low noise readout	Intelligent low-noise electronics offer the most 'silent' system noise performance available
4-speed readout < 5 MHz ⁹	Slower readout for low noise, faster speeds for dynamic processes and 5 MHz for visualisation mode
Broad wavelength range coverage	Maximise detection from UV to NIR. BEX2-DD (UV-NIR Broadband) BU2 (UV), BV (visible)

Andor iKon-L Series

Integrated shutter ¹¹	F-mount (EF optional) with integrated programmable 45 mm shutter
----------------------------------	------------------------------------------------------------------

Andor iKon-M Series

Multi-Megahertz pixel readout	Accelerate imaging speeds
-------------------------------	---------------------------

Applications

Life science

The iKon series is the proven benchmark for luminescence detection and other imaging experiments involving extremely weak signals that require extended exposure times of minutes or even hours. Back-illuminated sensors with a wide spectral response deliver optimal photon collection, while thermoelectric cooling to -100°C and proprietary electronics minimise thermal noise to ensure the lowest possible noise floor.

- Bio/Chemi luminescence
- *In vivo* luminescence imaging
- Biochip reading
- Bacterial & plant luminescence studies
- Laser induced fluorescence (LIF)
- Fluorescence microscopy

IN VIVO LUMINESCENCE

In vivo luminescence imaging experiments typically require signal integration times up to 20 mins, making dark current the main component of the overall noise. iKon cameras have been used for many years to image tumours and other diseases and their response to different therapeutic candidates due to the combination of high sensitivity and ultra-low dark current. The iKon-M uses a standard C-mount, whereas the iKon-L uses a F-mount to allow an extra-large imaging area of 39 mm diagonal. For the very lowest signals, it is also possible to further enhance detection using binning, this increases the effective pixel size, thus improving the signal to noise.

BIOCHIP READING

Biochip experiments vary widely with some requiring long exposures to detect faintly emitted signals. For these experiments the iKon series is an ideal option due to the high sensitivity and lowest noise floor over extended exposures times. The large 27.6 x 27.6 mm sensor format of the iKon-L allows for the maximum image information to be acquired in each snap. When higher speed acquisition is required we recommend the higher speeds of sCMOS cameras such as the 24.5 Megapixel CB2 High Res that is equipped high-frame rate capabilities and global shutter.

PLANT SCIENCE RESEARCH

Studies of plant species such as *A. thaliana* using luminescence-based experiments provide an effective means to study many aspects of plant growth, development and regulation. Such experiments involve measurement of weak signals over extended periods. The iKon series is perfectly suited to these applications. Exceptional sensitivity extends across the 400 to 700 nm region. The deep cooled sensors provide the lowest noise floor enabling extended exposures beyond seconds into minutes. The iKon-L model has a wide field of view of 39 mm meaning that more data and more context can be viewed in each image.

High sensitivity and the exceptionally low dark current makes iKon-M a perfect solution for the most demanding long exposure luminescence experiments such as plant imaging studies. [Read our full case study here.](#)

Example of bioluminescence timelapse of *Arabidopsis* to investigate the circadian clock. Courtesy of Professor Liu (Liu Lab, Shanghai Institutes for Biological Sciences, CAS, Shanghai)

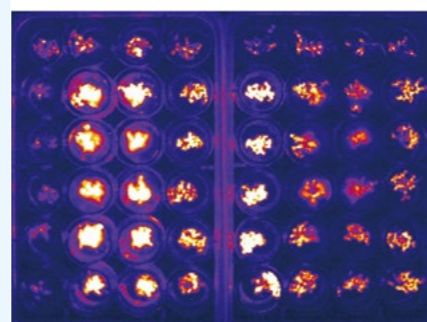

iKon slow-scan large CCD cameras for physical science

The iKon 'slow scan' CCD camera series delivers unique thermoelectric cooling to -100°C for industry-leading low noise performance, highly efficient back-illuminated photon collection across a broad spectral range and exceptional dynamic range. The robust quality, low maintenance, hassle-free design is ideal for usage across many experimental set-ups, including at remote observatories.

ASTRONOMY

Andor's back-illuminated iKon CCD cameras represent ideal solutions in multiple fields of astronomical research. The iKon-L's large field of view is just as useful in wide field imaging as it is in high resolution echelle spectroscopy. Owing to its high broadband sensitivity (>90% peak) at visible and NIR wavelengths, its low noise floor, and its cryogen-free dark current suppression, the iKon series reliably supports precise photometry of extremely faint astronomical targets. Andor's UltraVac Technology is particularly beneficial at remote and automated observatories



that are not visited frequently for servicing. The sustained vacuum integrity of Andor's UltraVac technology removes the need for re-pumping, reduces instrument down-time, increases observatory productivity, and lowers the camera's cost of ownership.

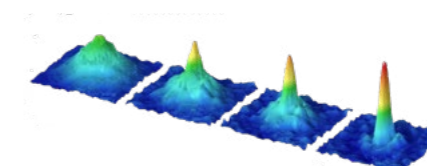

BOSE-EINSTEIN CONDENSATION (BEC)

The high and broad QE profile of the iKon-L provides excellent coverage of the visible / NIR wavelength range, often needed to image ultracold fermions at wavelengths of 670 nm and above, in both fluorescence and absorption type set-ups.

HYPER-SPECTRAL IMAGING

Often there is a desire for the highest number of spectral channels possible with ideal resolution; the large FOV and pixel size of the iKon series offers significant extensions to hyper spectral imaging.

NEUTRON RADIOGRAPHY

Traditionally CCD's have been used as imaging cameras for neutron tomography. Andor's scientific range of imaging cameras are ideal with their extremely low noise, -100°C cooling and highest QE delivering optimal performance.

Technical data^{•2}

Model	iKon-L Models		iKon-M Models	
Sensor type	BV Back Illuminated CCD, Vis optimised BEX2-DD: Back Illuminated CCD, Deep Depletion with fringe suppression, extended range dual AR coating		BU2: Back Illuminated CCD, UV-Enhanced, 250 nm optimised BV: Back Illuminated CCD, Vis optimised BEX2-DD: Back Illuminated CCD, Deep Depletion with fringe suppression, extended range dual AR coating	
Active pixels ^{•3}	2048 x 2048		1024 x 1024	
Pixel size	13.5 x 13.5 µm		13 x 13 µm	
Image area	27.6 x 27.6 mm with 100% fill factor		13.3 x 13.3 mm with 100% fill factor	
Minimum temperatures ^{•4}	4-stage peltier cooler: Air cooled -70°C Coolant recirculator -75°C Coolant chiller, coolant @ 10°C, 0.75 l/min -80°C 5-stage peltier cooler: Air cooled -80°C Coolant recirculator -95°C Coolant chiller, coolant @ 10°C, 0.75 l/min -100°C		Air cooled: -80°C Coolant recirculator: -95°C Coolant chiller, coolant @ 10°C, 0.75 l/min: -100°C	
Blemish specification	Grade 1 sensor from supplier. Camera blemishes as defined by Andor Grade A: andor.oxinst.com/learning/view/article/ccd-blemishes-and-non-uniformities			
System window type	BV sensor: UV-grade fused silica, 'Broadband VIS-NIR', unwedged BEX2-DD sensor: UV-grade fused silica, 'Broadband VUV-NIR', unwedged		BU2 sensor: UV-grade fused silica, 'Broadband VUV-NIR', unwedged BV sensor: UV-grade fused silica, 'Broadband VIS-NIR', wedged BEX2-DD sensor: UV-grade fused silica, 'Broadband VUV-NIR', wedged (other options available e.g. Bose-Einstein 780 nm for Rb BEC experiments)	
Interface	USB 2.0			
Lens mount	F-mount			
Model	iKon-L Models		iKon-M Models	
	936 BV sensor	936 BEX2-DD	934 BU2 and BV	BEX2-DD
Dark current, e-/pixel/sec ^{•5}	@ -70°C 0.00040 @ -80°C 0.00013 @ -100°C (5-stage peltier cooler iKon-L model only) 0.000059	@ -70°C 0.020 @ -80°C 0.006 @ -100°C (5-stage peltier cooler iKon-L model only) 0.0003	@ -80°C 0.00030 @ -100°C 0.00012	@ -80°C 0.01700 @ -100°C 0.00047
Pixel readout rates	5, 3, 1, 0.05 MHz			
Active area pixel well depth	100,000 e-	150,000 e-	100,000 e-	130,000 e-
Read noise (e-) ^{•6}	High Sensitivity output (High Capacity output)		2.9	3.3
0.05 MHz	2.9 (8.7)		6.6	6.2
1 MHz	7.0 (22.2)		11.6	9.2
3 MHz	11.7 (40.2)		18.0	13.6
5 MHz ^{•9}	31.5 (70.3)			
Linearity ^{•7}	Better than 99%			
Digitisation	16-bit			
Vertical clock speed	38 or 76 µs (software selectable)		11.3 to 67.3 µs (software selectable)	4.25 to 64.25 µs (software selectable)

iKon-L 936 Frame Rates^{•8}

50 kHz			
Binning	Full Frame	1024 x 1024	512 x 512
1 x 1	0.011	0.023	0.046
2 x 2	0.040	0.059	0.102
4 x 4	0.155	0.138	0.213
8 x 8	0.482	0.293	0.420
16 x 16	1.166	0.572	0.780

3 MHz			
Binning	Full Frame	1024 x 1024	512 x 512
1 x 1	0.607	1.157	2.115
2 x 2	1.294	2.175	3.588
4 x 4	2.305	3.545	5.326
8 x 8	3.463	5.017	6.953
16 x 16	4.496	6.270	8.180

1 MHz			
Binning	Full Frame	1024 x 1024	512 x 512
1 x 1	0.221	0.433	0.835
2 x 2	0.662	0.993	1.670
4 x 4	1.594	1.947	2.951
8 x 8	2.912	3.266	4.571
16 x 16	4.152	4.710	6.204

5 MHz Visualisation mode ^{•9}			
Binning	Full Frame	1024 x 1024	512 x 512
1 x 1	0.953	1.771	3.100
2 x 2	1.655	2.922	4.733
4 x 4	2.619	4.329	6.424
8 x 8	3.697	5.700	7.822
16 x 16	4.654	6.776	8.777

iKon-L QE^{•10}

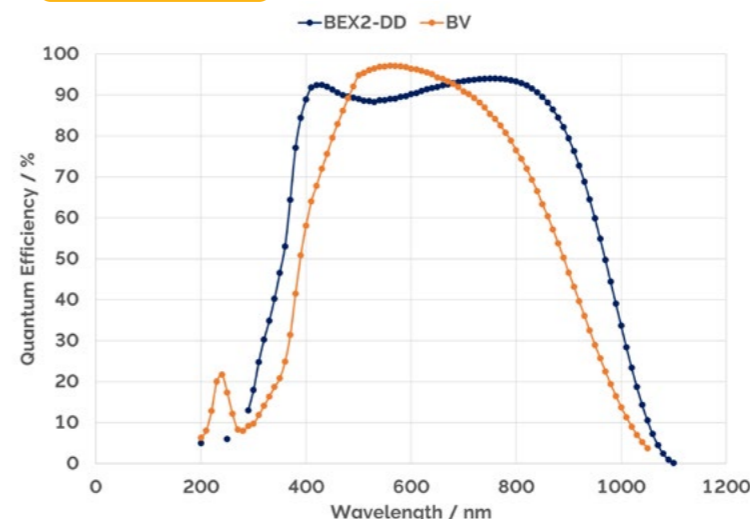

iKon-M 934 Frame Rates^{•8}

50 kHz				
Binning	Full Frame	512 x 512	256 x 256	128 x 128
1 x 1	0.04	0.1	0.2	0.4
2 x 2	0.2	0.2	0.4	0.8
4 x 4	0.6	0.6	0.9	1.5
8 x 8	2.0	1.2	1.7	2.8
16 x 16	5.1	2.3	3.2	5

3 MHz				
Binning	Full Frame	512 x 512	256 x 256	128 x 128
1 x 1	2.6	5.2	10.0	18.6
2 x 2	6.3	10.9	19.3	33.2
4 x 4	13.4	20.9	34.2	53.5
8 x 8	25.1	36.3	54.4	76.5
16 x 16	41.5	56.1	76.5	97.1

1 MHz				
Binning	Full Frame	512 x 512	256 x 256	128 x 128
1 x 1	0.9	1.8	3.5	6.9
2 x 2	2.9	4.3	7.5	13.5
4 x 4	7.9	9.4	14.8	24.6
8 x 8	18.0	18.2	26.6	40.7
16 x 16	33.4	31.6	43.0	59.8

5 MHz Visualisation mode ^{•9}				
Binning	Full Frame	512 x 512	256 x 256	128 x 128
1 x 1	4.4	8.5	16.0	28.8
2 x 2	8.4	15.9	28.5	47.6
4 x 4	15.6	28.1	47.0	70.8
8 x 8	27.3	45.8	69.4	93.5
16 x 16	43.6	66.9	91.2	111.5

iKon-M QE^{•10}

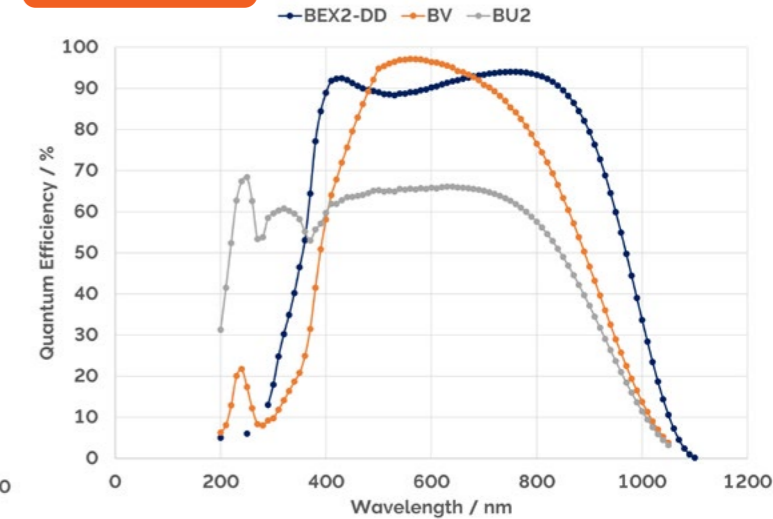

iKon-M Mechanical Drawings

Dimensions in mm [inches]
 Weight: ~3 kg [6.61 lbs] approx.

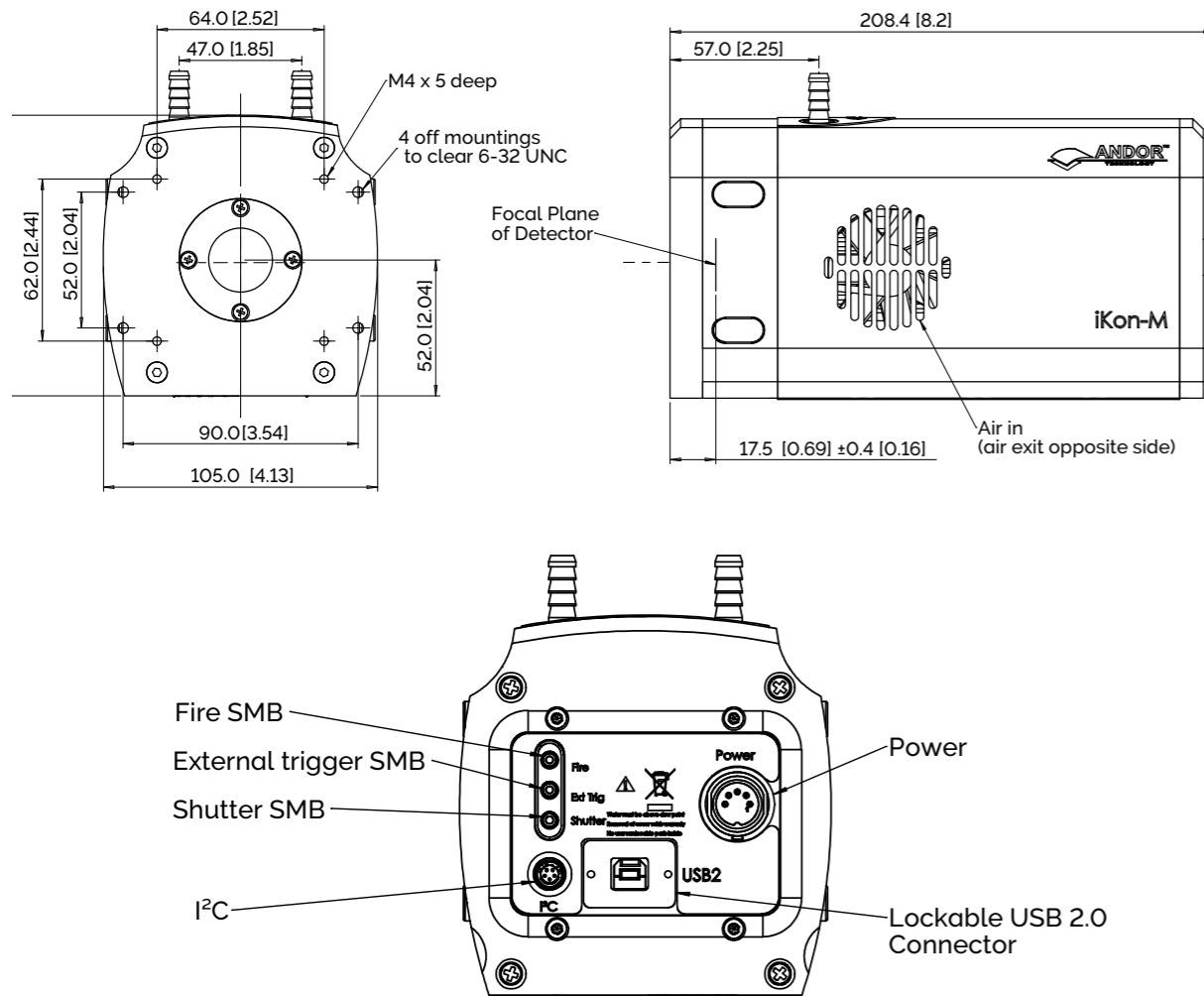
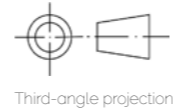

Connecting to the iKon-M

Camera Control

Connector type: USB 2.0 with optional lockable connector

TTL / Logic

Connector type: SMB, provided with SMB - BNC cable

Fire (Output), External Trigger (Input), Shutter (Output)

I²C connector

Compatible with Fischer SC102A054-130

Shutter (TTL), I²C Clock, I²C Data, +5 Vdc, Ground

Minimum cable clearance required at rear of camera 90 mm

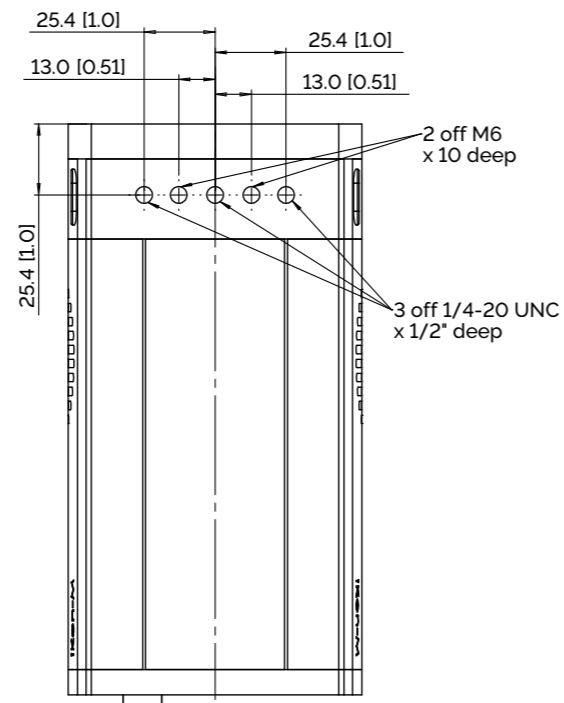

iKon- L Mechanical Drawings

Dimensions in mm [inches]
 Weight: 4.6 kg [10.2 lb]

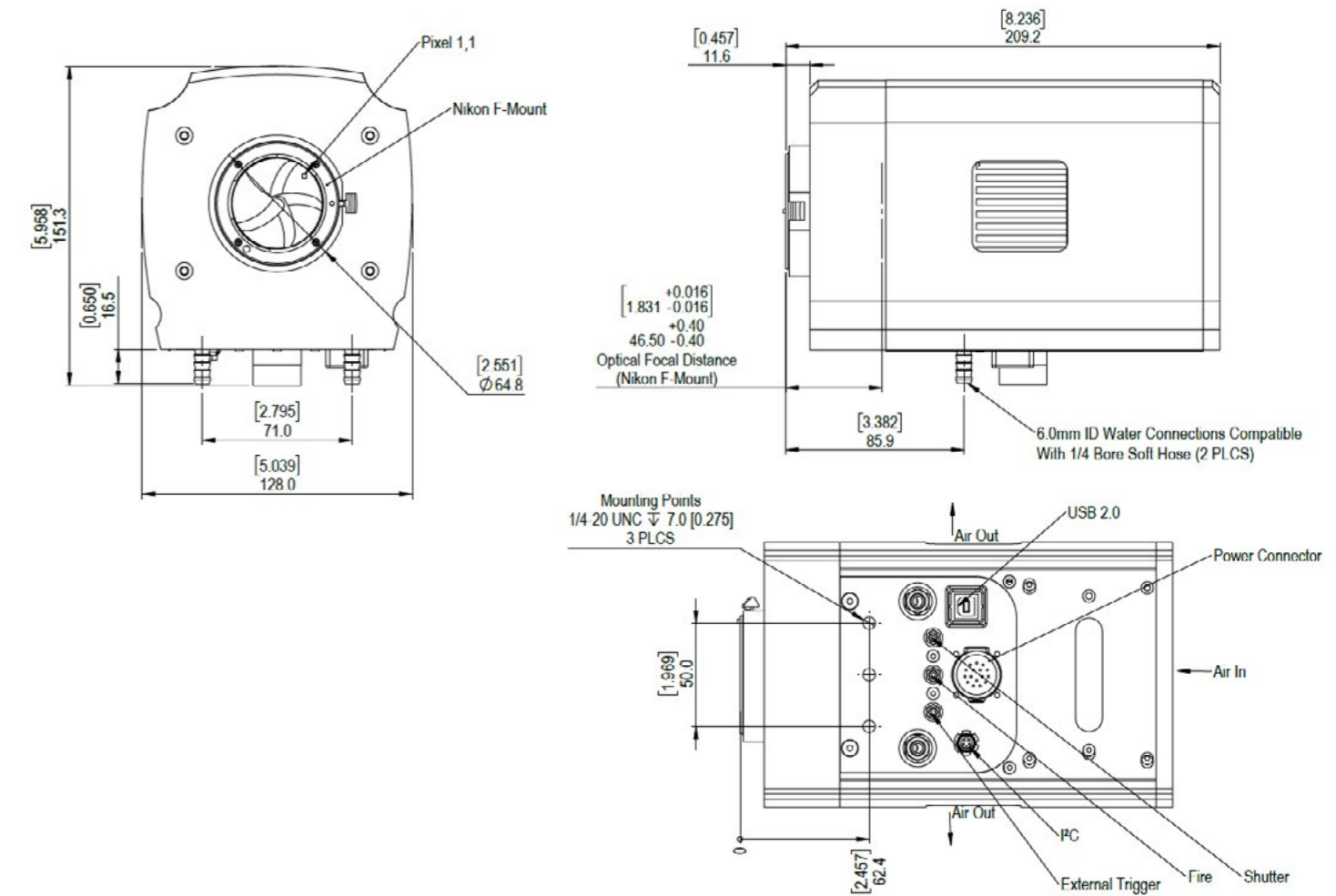
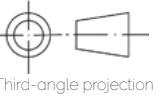

Connecting to the iKon-L

Camera Control

Connector type: USB 2.0

TTL / Logic

Connector type: SMB, provided with SMB - BNC cable

Fire (Output), External Trigger (Input), Shutter (Output)

I²C connector

Compatible with Fischer SC102A054-130

Shutter (TTL), I²C Clock, I²C Data, +5 Vdc, Ground

Minimum cable clearance required at bottom of camera 90 mm

Ordering the optimum product for you.

Step 1. Choose the camera type



Camera Type

iKon-L Description	Code
iKon-L with 4-stage peltier cooling (Air cooled : -70°C, Coolant recirculator: -75°C, Coolant chiller, coolant @ 10°C, 0.75 l/min: -80°C) Back Illuminated CCD	DW963N-BV
iKon-L with 4-stage peltier cooling (Air cooled : -70°C, Coolant recirculator: -75°C, Coolant chiller, coolant @ 10°C, 0.75 l/min: -80°C). Back Illuminated CCD, Deep Depletion with fringe suppression, extended range dual AR coating	DW963N-BV
iKon-L with 5-stage peltier cooling (Air cooled: -80°C, Coolant recirculator: -95°C, Coolant chiller, coolant @ 10°C, 0.75 l/min: : -100°C) Back Illuminated CCD	DZ963N-BV
iKon-L with 5-stage peltier cooling (Air cooled: -80°C, Coolant recirculator: -95°C, Coolant chiller, coolant @ 10°C, 0.75 l/min: : -100°C). Back Illuminated CCD, Deep Depletion with fringe suppression, extended range dual AR coating	DZ963N-BEX2-DD
iKon-M Description	Code
iKon-M 934 Camera, Back Illuminated CCD, Vis optimised	DU934P-BV
iKon-M 934 Camera, Back Illuminated CCD, AR coated for optimised performance in the 250 nm region	DU934P-BU2
iKon-M 934 Camera, Back Illuminated CCD, Deep Depletion with fringe suppression, extended range dual AR coating	DU934P-BEX2-DD



Camera window

The standard window has been selected to satisfy most applications. However, other options are available. The alternative camera window code must be specified at time of ordering.

To view and select other window options please refer to the [Camera Windows Selector Tool](#). Further detailed information on windows can be found in the technical note – [How to Select a Window for your Camera](#).

Step 2. Select the required accessories

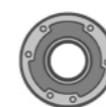

Accessories

Description	Order Code
Re-circulator for enhanced cooling performance	XW-RECR
Oasis 160 Ultra compact chiller unit (tubing to be ordered separately)	ACC-XW-CHIL-160
6 mm tubing options for ACC-XW-CHIL-160 (2x2.5 m or 2x5 m lengths)	ACC-6MM-TUBING-2X2.5 ACC-6MM-TUBING-2X5M
C-mount to Canon FD-mount adapter	OA-CCFM
C-mount to Nikon F-mount adapter	OA-CNAF
C-mount to Olympus OM adapter	OA-COFM
Auto extension tubes (set of 3) for Nikon F	OA-ENAF
Auto extension tubes (set of 3) for Nikon F	OA-ENAF
USB Extender: Icron USB 2.0 Ranger 2201 (supports up to 100 m) - EU/UK/US	ACC-USBX-EU ACC-USBX-UK ACC-USBX-US
30 m Ethernet cable (for use with the above ACC-USBX-** USB extenders)	ACC-ELC-13295

Step 3. Select the required software



Software

iKon requires one of the following software options:

Fusion Fully featured yet intuitive acquisition software. Integrated workflow to Imaris.

Solis Imaging A 64-bit enabled application for Windows (10 and 11) offering rich functionality for data acquisition and processing. AndorBasic provides macro language control of data acquisition, processing, display and export.

Andor SDK3 A software development kit that allows you to control the Andor range of cameras from your own application. Available as a 64-bit library for Windows (10 and 11) and Linux. Compatible with C/C++, C#, Delphi, VB.NET, LabVIEW, MATLAB and Python.

Third party software compatibility Drivers are available for a variety of third party imaging packages. [See the Andor website for detail](#).

- Assembled in a state-of-the-art cleanroom facility, Andor's UltraVac™ vacuum process combines a permanent hermetic vacuum seal (no o-rings), with a stringent protocol to minimize outgassing, including use of proprietary material.
- Figures are typical unless otherwise stated.
- Edge pixels may exhibit a partial response.
- Specified minimum air cooled temperature assumes ambient temperature of 25°C. Specified minimum temperature with coolant assumes coolant temperature of 10°C.
- The dark current measurement is averaged over the sensor area excluding any regions of blemishes.
- Readout noise is for the entire system. It is a combination of sensor readout noise and A/D noise. Measurement is for Single Pixel readout with the sensor at a temperature of -80°C and minimum exposure time under dark conditions.
- Linearity is measured from a plot of counts vs exposure time under constant photon flux up to the saturation point of the system.
- For **iKon-M 934** the frame rates shown are for a range of binning or array size combinations. All measurements are made with 11.29 μs vertical shift speed. It also assumes internal trigger mode of operation and minimum exposure time. For **iKon-L 936** the frame rates shown are for a range of binning or array size combinations. All measurements are made with 38 μs vertical shift speed. It also assumes internal trigger mode of operation and minimum exposure time.
- 5 MHz is for focusing/visualisation mode only.
- Quantum efficiency of the sensor at 25°C as supplied by the sensor manufacturer.
- For **iKon-L 936** the integrated shutter can be removed on request, and the camera configured to trigger an external shutter via TTL output.



Need more information? We are committed to finding the correct solution for you. With a dedicated team of technical advisors, we are able to offer you one-to-one guidance and technical support on all products.

For a full listing of our local sales offices, please see:

[andor.oxinst.com/contact](https://www.andor.oxinst.com/contact)

Our regional headquarters are:

Europe

Belfast, Northern Ireland

Phone +44 (28) 9023 7126

Japan

Tokyo

Phone +81 (3) 6744 4703

North America

Concord, MA, USA

Phone +1 (860) 290 9211

China

Beijing | Shanghai | Guangzhou

Phone +86 (400) 678 0609

Note

Oxford Instruments reserves the right to alter without notice the specification, design or conditions of supply of any product or service.

Original document in English

© Oxford Instruments

IKON-M&L-FAMILY-BR-0426 R1

www.oxinst.com