

# iKon-XL Hardware Guide

Version 2.1 rev 01 Oct 2024

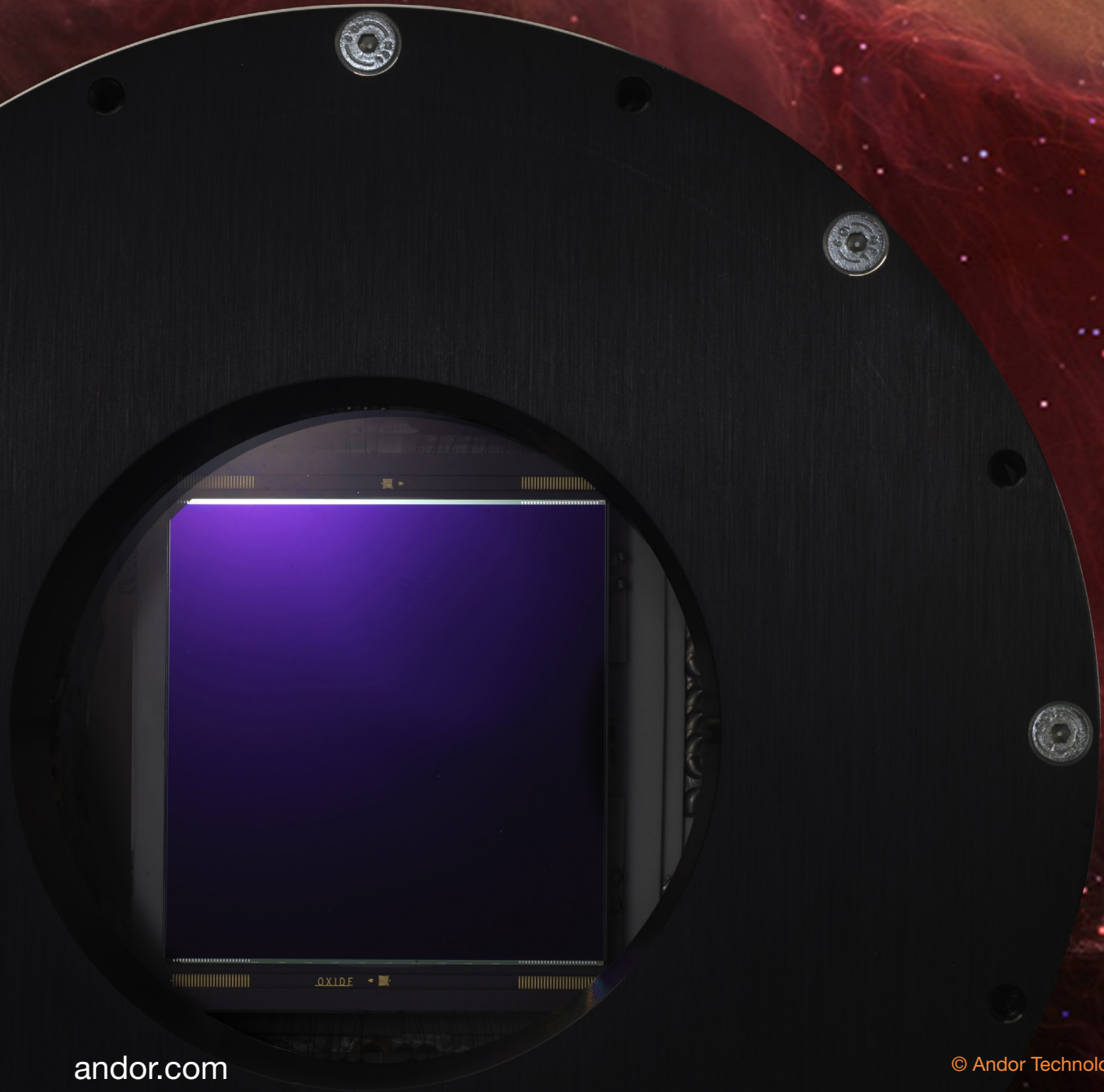

**TABLE OF CONTENTS**

<b>SECTION 1: INTRODUCTION</b> .....	<b>9</b>
1.1 TECHNICAL SUPPORT .....	10
1.2 DISCLAIMER .....	11
1.3 COPYRIGHT AND PROTECTIVE NOTICES.....	11
1.4 TRADEMARKS AND PATENT INFORMATION.....	11
1.5 SUPPLIED COMPONENTS .....	12
1.5.1 iKON-XL MODEL OPTIONS .....	13
1.5.2 OPTIONAL ACCESSORIES .....	14
1.5.3 REPLACEMENT SHUTTERS.....	14
<b>SECTION 2: PRODUCT OVERVIEW</b> .....	<b>15</b>
2.1 EXTERNAL FEATURES OF THE IKON XL .....	15
2.2 REAR PANEL .....	16
2.3 CAMERA CONTROL UNIT (CCU-500).....	18
2.4 POWER REQUIREMENTS .....	19
<b>SECTION 3: INSTALLATION</b> .....	<b>20</b>
3.1 TRANSPORT AND STORAGE INFORMATION .....	20
3.2 MOUNTING THE IKON XL USING THE MOUNTING FLANGE .....	20
3.3 ATTACHING TO MOUNTING POSTS.....	21
3.4 INSTALLING THE CCU-500 CAMERA CONTROL UNIT .....	21
3.5 CONNECTING THE IKON-XL TO THE PC.....	22
3.6 CONNECTING THE IKON-XL TO THE CAMERA CONTROL UNIT AND POWER SUPPLY .....	23
3.7 CONNECTING A COOLING SYSTEM.....	24
3.7.1 IMPORTANT CONSIDERATIONS WHEN USING LIQUID COOLING SYSTEMS .....	24
3.7.2 COOLING HOSE CONNECTORS.....	24
3.8 COOLANT RECOMMENDATIONS .....	25
3.9 CONNECTING THE LIQUID COOLING SYSTEM .....	25

3.9.1	CONNECTING THE COOLANT HOSES .....	25
3.9.2	DISCONNECTING THE COOLANT HOSES .....	25
3.10	INSTALLING SOFTWARE AND USB DRIVERS .....	26
3.10.1	MINIMUM COMPUTER REQUIREMENTS .....	26
3.10.2	INSTALLING SOLIS SOFTWARE AND USB DRIVERS .....	26
3.10.3	NEW HARDWARE WIZARD (WINDOWS).....	26
3.11	INSTALLING A USB 3.0 CARD (IF REQUIRED).....	27
3.11.1	DISABLING POWER MANAGEMENT FOR THE USB 3.0 HOST CONTROLLER.....	27
3.12	INSTALLING A FIBRE OPTIC CARD.....	27
3.12.1	INSTALLING FIBRE OPTIC CARD DRIVERS (WINDOWS ONLY) .....	28
<b>SECTION 4: OPERATION .....</b>		<b>29</b>
4.1	EMERGENCY MAINS DISCONNECTION .....	29
4.2	POWER-UP SEQUENCE.....	29
4.3	POWER-DOWN SEQUENCE.....	29
4.4	USING THE IKON-XL .....	29
<b>SECTION 5: MAINTENANCE.....</b>		<b>30</b>
5.1	REGULAR CHECKS .....	30
5.2	ANNUAL ELECTRICAL SAFETY CHECKS .....	30
5.3	GENERAL CLEANING & DECONTAMINATION INFORMATION.....	30
5.4	CLEANING THE CAMERA WINDOW.....	30
5.4.1	TOOLS REQUIRED .....	31
5.4.2	WINDOW CLEANING PROCEDURE.....	31
5.5	FUSE REPLACEMENT .....	31
5.6	REPLACEMENT OF THE SHUTTER.....	32
5.7	COOLING HOSES AND CONNECTIONS.....	32
5.8	CCU-500 COOLING FANS .....	32
<b>SECTION 6: TROUBLESHOOTING .....</b>		<b>33</b>
6.1	PREVENTING CONDENSATION .....	33
6.2	QUICK TROUBLESHOOTING GUIDE.....	33

APPENDIX A: TECHNICAL SPECIFICATIONS..... 34

APPENDIX B: MECHANICAL DRAWINGS..... 37

APPENDIX C: DEWPOINT INFORMATION ..... 40

APPENDIX D: REFERENCE INFORMATION..... 41

APPENDIX E: OTHER INFORMATION ..... 44



## REVISION HISTORY

Version	Released	Description
1.0	30 Nov 2016	Initial Release
1.1	13 Jan 2017	Provided additional clarification on sensor variants (Sections 1.5.1, 2.1 and Appendix A). Updated power requirements (Appendix A).
1.2	30 Jun 2017	Updated Mechanical Drawing for Deep Cooled model (Appendix B).
1.3	13 Oct 2017	Expanded and updated fibre optic card and USB 3 connection information (Sections 3.11 and 3.12).
1.4	18 Dec 2017	Camera I/O logic information expanded (Section 2.2). Added some further more detail during installation steps (Section 3). Further updates to software installation steps (Sections 3.11 and 3.12). Added link to decontamination form (Section 5.3).
1.5	14 Mar 2018	Corrected active pixels of 231 sensor model to 4096 x 4108 and aligned specs with Specification Sheet. Added further details on iRIG-B (Section 2.2). Updated software installation steps- including Linux (Section 3.10) Updated power requirements (Appendix A). Added notes to indicate the fibre optic is multimode type and that CCU-500 can be remotely powered on and off.
1.6	10 May 2018	Clarified mounting information (Section 3.2). Updated information on condensation risks and prevention (Sections 3.1 and 6.1)
1.7	17 Jul 2018	Added information on Sensor Compensation and Baseline clamp software settings (Appendix D)
1.8	24 Apr 2019	Updated USA and Asia-Pacific office addresses.
1.9	21 Oct 2019	Updated mechanical drawings and backplate views. Updated China office address.
2.0	18 Sep 2024	Updated Environmental Specifications table (Appendix A)
2.1	01 Oct 2024	Removed iKon-XL Model Options and Sensor Models due to obsolescence (Section 1.5.1)

## UPDATES TO THE MANUAL

Changes are periodically made to the product and these will be incorporated into new editions of the manual. Please check for new releases of the manual in MyAndor: <http://my.andor.com/login.aspx>. If you find an issue in this manual please contact your customer support representative (Section 1.1) with a description of the issue.

## SAFETY AND WARNING INFORMATION

**READ THIS INFORMATION FIRST**

1. If the equipment is used in a manner not specified by Andor, the protection provided by the equipment may be impaired.
2. Before using the system, please follow and adhere to all warnings, safety, manual handling and operating instructions located either on the product or in this Hardware Guide.
3. Users must be authorised and trained personnel only; otherwise this may result in personal injury, and/ or equipment damage and impaired system performance.
4. There are no user-serviceable parts inside the product and the enclosure must not be opened. Only authorised service personnel may service this equipment.
5. Do not position this product so that it is difficult to operate the Mains disconnecting device. See SECTION 4.1, “Emergency Mains Disconnection”.
6. Protective earth is an integral part of the protection against electric shock in this product, and is provided via the earth pin of the external power supply. Ensure that this is plugged into the building earth system via the mains socket. Do not tamper with any of the earthing measures.
7. Only the correctly specified mains supply should be used.
8. Only the AC/DC external power supply provided with the product should be used.
9. Only the power supply cord provided with the product should be used. Should this not be correct for your geographical area, contact your local Andor representative.
10. Make sure the power supply cord is located so that it will not be subject to damage. If replacement of the detachable power supply cord is required, ensure replacement is of same type and rating.
11. Only use the CCU-500 configured for the specified cable length. Using a 5 m cable with a unit configured for 15 m cable may result in damage to the camera.
12. Performance of the system may be adversely affected by rapidly changing environmental conditions or operation outside of the operating conditions specified in “TECHNICAL SPECIFICATIONS”
13. While running an experiment, try to keep temperature as stable as possible.
14. This equipment has not been designed and manufactured for the medical diagnosis of patients.
15. Electromagnetic Compatibility: This is a Class A product. In a domestic environment this product may cause electromagnetic interference, in which case the user may be required to take adequate measures.
16. This product has been designed and tested to perform successfully in a normal (basic) electromagnetic environment, e.g. a typical life science test laboratory, as per the EU EMC Directive. It is not designed to operate in a harsh electromagnetic environment, e.g. close to the following equipment: EMI/RFI generators, electrostatic field generators, electromagnetic or radioactive devices, plasma sources, arc welders, x-ray instruments, intense pulsed sources, or other similar sources of high energy fields whose emissions are not within the normal range expected under the EU EMC Directive.
17. Please note that this product is not designed to provide protection from ionising radiation. Any customer using this product in such an application should provide their own protection.
18. Your product is a precision scientific instrument containing fragile components. Always handle it with care.

19. Ensure fibre cables are not bent tightly as this may damage the internal optical fibre. For transport or storage, fibre cables should be coiled loosely with a diameter of 300 mm or greater.
20. Do not wet or spill liquids on the product, and do not store or place liquids on the product.
21. If spillage occurs on the product, switch off power immediately, and wipe off with a dry, lint-free cloth.
22. If any ingress of liquids has occurred or is suspected, unplug the mains cables, do not use, and contact Andor Customer Support.
23. When using a liquid cooling system it is recommended that an overpressure device is fitted to avoid leaks that may find their way to the mains electricity supply and create a hazard. Refer to the information in SECTION 3.7 for general guidelines on the correct installation and use of a liquid cooling system.
24. See SECTION 5.1, "Cleaning and Decontamination".
25. Do not expose the product to extreme hot or cold temperatures.
26. Do not expose the product to open flames.
27. Do not allow objects to fall on the product.
28. Keep this hardware guide in a safe place for future reference.

## WARNING AND SAFETY LABELS

The following warning labels appear on the product:



When connected via the fibre optic connection the iKon-XL is classified as a Class 1 laser product under IEC 60825-1 and CDRH Title 21 CFR 1040.10. The Class 1 laser classification indicates that emissions are safe under all conditions of normal use and does not constitute an eye or skin hazard.



The Camera Control Unit (CCU-500) contains hazardous voltages (100-240 VAC). Do not attempt to open the CCU-500 enclosure. There are no user serviceable components inside.

The CCU-500 product identification and serial label (above left) shows the product model and serial numbers and build date. It is located on the right side panel.

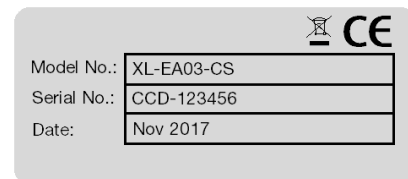

**CCU-500 Manufacturer: Andor Technology Ltd., Belfast, BT12 7AL, UK.**

The serial label of the iKon-XL (above right) is located on the side plate of the camera. It shows the product model and serial numbers and build date.

## WORKING WITH OPTICAL FIBRES

1. Optical fibres can easily be damaged by bending or general mishandling. Ensure that the minimum curvature is never exceeded when handling. Recommended minimum bend radius is 30 mm.
2. Optical fibres are prone to damage by bending local to the connector. Take care that the fibre optic cable has adequate strain relief/support at the connection and that the routing avoids tight radii.
3. The coupler is not designed to withstand pulling of the fibre- always insert or remove using the connector body. If the fibre is pulled the system performance could be compromised or the system may fail.

## UNPACKING INFORMATION

Carefully unpack the unit and retain the packaging materials to transport or return equipment if required:

- If the equipment appears damaged in any way, return it to sales outlet in its original packaging.
- No responsibility for damage arising from the use of non-approved packaging will be accepted.
- Ensure all items and accessories specified at the time of ordering and as detailed on the packing list are present: if any items are missing, please contact your sales representative.
- The camera has an uneven weight distribution- take care when lifting.
- The camera has a shipping cover - remove before use and store in a safe place so it may be used at a future time.



## SECTION 1: INTRODUCTION

---

This manual provides an overview of the iKon-XL camera series. The iKon-XL houses several large area high resolution CCD sensor variants and housing and cooling configurations to suit demanding applications such as Astronomy or X-ray/Neutron radiography (see Section 1.5.1). This manual includes a description of the main features of the iKon-XL, installation, routine operation and troubleshooting. It also provides a summary of some of the technical features of the iKon-XL series. For further information on operation and control of the iKon-XL refer to the relevant software guide e.g. Solis, and to the andor website for further technical information to help you get the best from your camera.

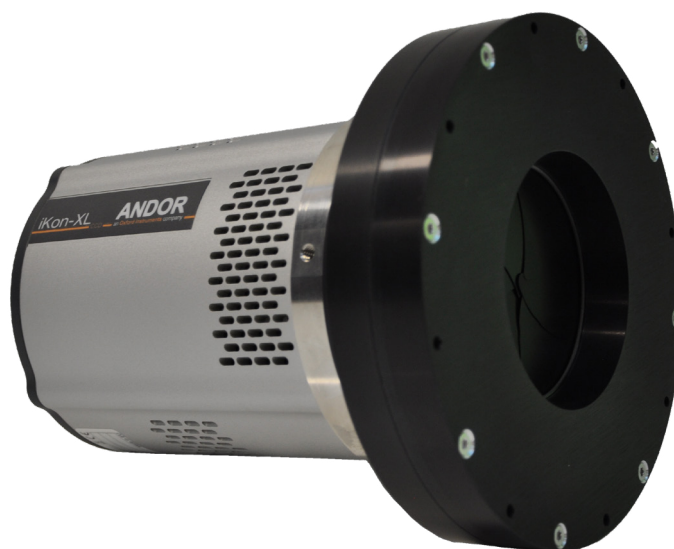

Figure 1: The iKon-XL (Flexi-model shown)

## 1.1 TECHNICAL SUPPORT

If you have any questions regarding the use of this equipment, please contact the representative\* from whom your system was purchased, or:

### Europe

Andor Technology Ltd.  
7 Millennium Way  
Springvale Business Park  
Belfast  
BT12 7AL  
Northern Ireland  
Tel. +44 (0) 28 9023 7126  
Fax. +44 (0) 28 9031 0792

### USA

Andor Technology  
300 Baker Avenue  
Suite # 150  
Concord  
MA 01742  
USA  
Tel. +1 (860) 290-9211  
Fax. +1 (860) 290-9566

### Asia-Pacific

Andor Technology (Japan)  
5F IS Building  
3-32-42 Higashi-Shinagawa  
Tokyo 140-0002  
Japan  
Tel: +81 (0) 3 6732 8968  
Fax: +81 (0) 3 6732 8939

### China

Andor Technology (China)  
Haitong Times Business Center,  
Building B2 West,  
No.11 West Third Ring North Road,  
Haidian District,  
Beijing,  
100089  
China  
Tel: +86 (0) 10 5884 7900  
Fax. +86 (0) 10 5884 7901

\* The latest contact details for your local representative can be found on the [Contact and Support](#) page of our website.

## 1.2 DISCLAIMER

THE INFORMATION CONTAINED HEREIN IS PROVIDED “AS IS” WITHOUT WARRANTY, CONDITION OR REPRESENTATION OF ANY KIND, EITHER EXPRESS, IMPLIED, STATUTORY OR OTHERWISE, INCLUDING BUT NOT LIMITED TO, ANY WARRANTY OF MERCHANTABILITY, NON-INFRINGEMENT OR FITNESS FOR A PARTICULAR PURPOSE.

IN NO EVENT SHALL ANDOR BE LIABLE FOR ANY LOSS OR DAMAGE, WHETHER DIRECT, INDIRECT, SPECIAL, INCIDENTAL, CONSEQUENTIAL OR OTHERWISE HOWSOEVER CAUSED WHETHER ARISING IN CONTRACT, TORT OR OTHERWISE, ARISING OUT OF OR IN CONNECTION WITH THE USE OF THE INFORMATION PROVIDED HEREIN.

PLEASE NOTE, AI TRANSLATIONS OF THIS USER MANUAL MAY RESULT IN INCORRECT INFORMATION. IN THE EVENT OF A CONFLICT WITH A FOREIGN LANGUAGE TRANSLATION, ANDOR’S ENGLISH TRANSLATION WILL PREVAIL.

## 1.3 COPYRIGHT AND PROTECTIVE NOTICES

The copyright in this document and the associated drawings are the property of Andor Technology Ltd. and all rights are reserved. This document and the associated drawings are issued on condition that they are not copied, reprinted or reproduced, nor their contents disclosed.

The publication of information in this documentation does not imply freedom from any patent or proprietary right of Andor Technology Ltd. or any third party.









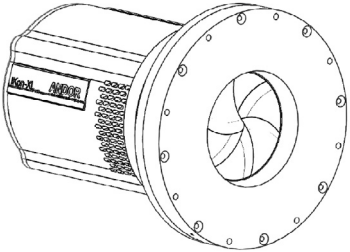



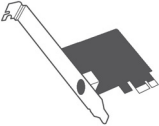

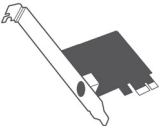
## 1.4 TRADEMARKS AND PATENT INFORMATION

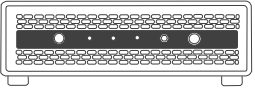
Andor and the Andor logo are trademarks of Andor Technology Ltd. Andor Technology Ltd. is an Oxford Instruments company. All other marks are property of their owners.

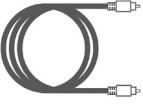
iKon-XL Manufacturers Information  
**Andor Technology Ltd., Belfast, BT12 7AL, UK.**

## 1.5 SUPPLIED COMPONENTS

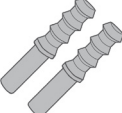

Description		Quantity
	<p><b>iKon-XL CCD Camera</b></p> <p>(model as ordered: refer to Section 1.5.1 Supplied with shipping plate fitted)</p>	1

	<p><b>Software &amp; Driver CDs (or Flash Drive)</b> (Solis and SDK are ordered separately)</p>	1		<p><b>Hardware Guide in electronic format</b></p>	1
	<p><b>Fibre Optic PCIe Card</b></p>	1		<p><b>Quick Start Guide</b></p>	1
	<p><b>USB3 PCIe Card</b></p>	1		<p><b>Fibre optic LC-LC (multimode) (15 m)</b></p>	1
	<p><b>CCU-500 Camera Control Unit and country specific power cord</b></p>	1		<p><b>BNC-SMA Cable (2 m)</b></p>	3
	<p><b>CCU-500 to camera cable (5 m as standard)</b></p>	1		<p><b>USB 3.0 Cable (3 m)</b></p>	1
	<p><b>CCU-500 19" mounting brackets- pair. Includes 6 off M5 x 10 csk screws</b></p>	1		<p><b>Anti-static Wrist band</b></p>	1
	<p><b>CCU-500 mounting lugs. Includes 6 off M5 x 10 csk screws</b></p>	1		<p><b>Coolant hose inserts</b></p>	2
	<p><b>Performance Booklet</b></p>	1		<p><b>Hex Key (3 mm)</b></p>	1

## 1.5.1 iKon-XL MODEL OPTIONS

There are a number of models of iKon XL, based on either the “230” or the “231” sensor (see also Section 2.1). The options for each model can be identified by the product codes as outlined below:



### iKon-XL 230 Sensor Models

Sensor Types 		Cooling Options 		Shutter Options 	
Description	Code	Description	Code	Description	Code
BV: midband AR coating	<b>EA01</b>	Flexi Cooling (max. cooling -75°C @ coolant temp of 10°C; -55°C max. air cooling)	<b>C</b>	Standard (0°C and +30°C)	<b>S</b>
				No Shutter	<b>0</b>

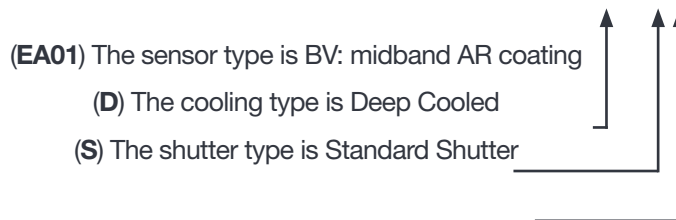
Therefore, for the following example the **iKon-XL 230 camera** with model code **XL-EA01-DS** would have the following options:



### iKon-XL 231 Sensor Models

Sensor Types 		Cooling Options 		Shutter Options 	
Description	Code	Description	Code	Description	Code
BV: midband AR coating	<b>EA03</b>	Flexi Cooling (max. cooling -75°C @ coolant temp of 10°C; -55°C max. air cooling)	<b>C</b>	Standard (0°C and +30°C)	<b>S</b>
EX2 dual AR coating	<b>EA05</b>			No Shutter	<b>0</b>
BR-DD deep depletion with fringe suppression	<b>EA06</b>				
BEX2-DD deep depletion with fringe suppression and dual AR coating	<b>EA07</b>				

Therefore, for the following example the **iKon-XL 231 camera** with model code **XL-EA05-CS-EXT** would have the following options:

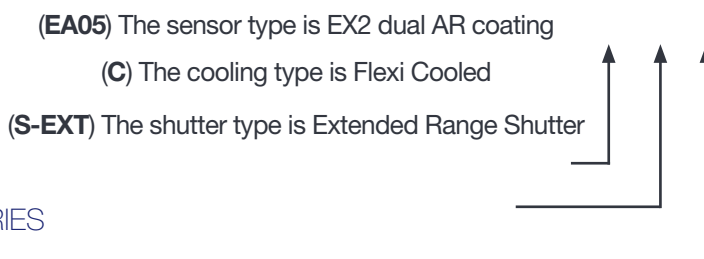

## 1.5.2 OPTIONAL ACCESSORIES

A range of accessories is available for the iKon-XL (see table below). The iKon-XL is intended only for use with accessories



supplied and recommended by Andor. Please contact your local Andor representative if further information is required.

Description	Code
15 m camera cable with straight attachment for the CCU-500A (iKon-XL Flexi model) If this is ordered it will be provided <i>instead</i> of the standard 5 m cable.	<b>XL-F-CAB-ST-15M</b>
15 m camera cable with straight attachment for the CCU-500B (iKon-XL Deep Cooled model) If this is ordered it will be provided <i>instead</i> of the standard 5 m cable.	<b>XL-DC-CAB-ST-15M</b>
Additional 25 m multimode fibre optic cable, LC-LC patch lead OM2.	<b>FIBR-25M</b>
Additional 100 m multimode fibre optic cable, LC-LC patch lead OM3.	<b>FIBR-100M</b>
Hard shell protective transport case for the iKon-XL Flexi model. Tailored to dimensions of the iKon-XL Flexi model for secure transport to and from observing sites.	<b>XL-F-TRANS-CASE</b>
Hard shell protective transport case for the iKon-XL Deep Cooled model. Tailored to dimensions of the iKon-XL Deep Cooled model for secure transport to and from observing sites.	<b>XL-DC-TRANS-CASE</b>

### 1.5.3 REPLACEMENT SHUTTERS

Description	Code
Replacement 'standard' shutter unit for the iKon-XL. For use between 0°C and +30°C ambient temperatures.	<b>XL-SH-STD</b>
Replacement 'extended temperature range' shutter unit for the iKon-XL. For use between -30°C and +30°C ambient temperatures.	<b>XL-SH-EXT</b>

## SECTION 2: PRODUCT OVERVIEW

This section provides an overview of the iKon-XL. Please note that iKon-XL configuration including housing, cooling

connectivity and mounting flange may vary for your specific model. Please refer to the additional information supplied for details of any model specific differences.

**Flexi-Cooling Model:** May be configured for air or liquid cooling. With liquid cooling it provides max. cooling of  $-80^{\circ}\text{C}$  [ $75^{\circ}\text{C}$ ] at a coolant temp of  $10^{\circ}\text{C}$  [ $16^{\circ}\text{C}$ ]. When set for air cooling, a maximum cooling of  $-60^{\circ}\text{C}$  may be achieved.

**Deep Cooled Model:** The deep cooled model facilitates liquid cooling only, achieving a maximum cooling of  $-100^{\circ}\text{C}$  [ $95^{\circ}\text{C}$ ] at a coolant temp of  $10^{\circ}\text{C}$  [ $16^{\circ}\text{C}$ ].

## 2.1 EXTERNAL FEATURES OF THE iKON XL

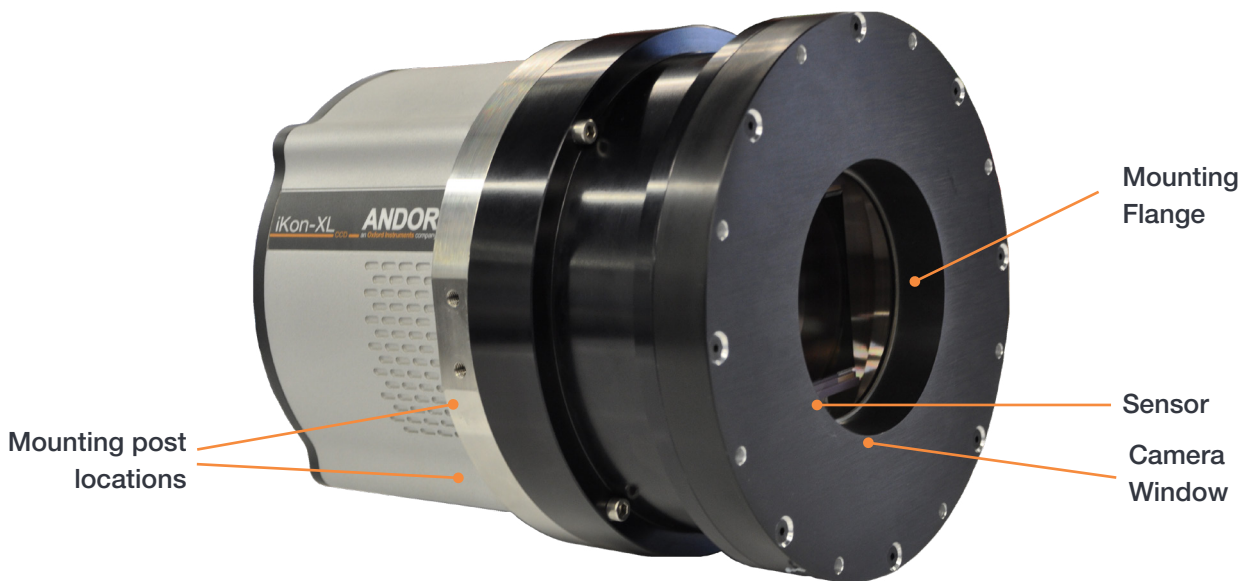

Figure 2: iKon-XL (Deep Cooled model shown)

### Mounting Flange

The standard configuration of mounting flange has 8 x threaded holes for M5 bolts on 189 PCD. Refer to the additional supplied information or specification sheet appropriate for your specific model.

### Sensor

The iKon-XL features high resolution CCD sensors such as the CCD-230-84 or CCD-231-84 16.8 Megapixel CCD sensors. Andor's unique UltraVac™ vacuum technology has been applied to the iKon-XL. UltraVac provides a permanent hermetically sealed enclosure for maximum QE and cooling performance over many years operation.

### Camera Window

The standard iKon-XL features a Single AR coated UV grade silica window for optimum transmission. For more information on camera windows please see <http://www.andor.com/learning-academy/camera-windows-optimizing-for-different-spectral-regions>.

### Shutter

A mechanical shutter is an option for the iKon-XL for e.g. dark-frame subtraction for flat-field correction of long exposure images. Where applicable, the shutter is mounted onto the faceplate. This has been designed so that simple in-field replacement of the shutter is possible.

### Mounting Post Locations

**Deep Cooled model:** Four sets of 2x  $\frac{1}{4}$  -20 UNC mounting holes are located at each 90 degrees.

**Flexi-cooling model:** Four sets of 1x ¼ -20 UNC mounting holes are located at each 90 degrees.

## 2.2 REAR PANEL

Figure 3: Rear Panel

### USB 3.0

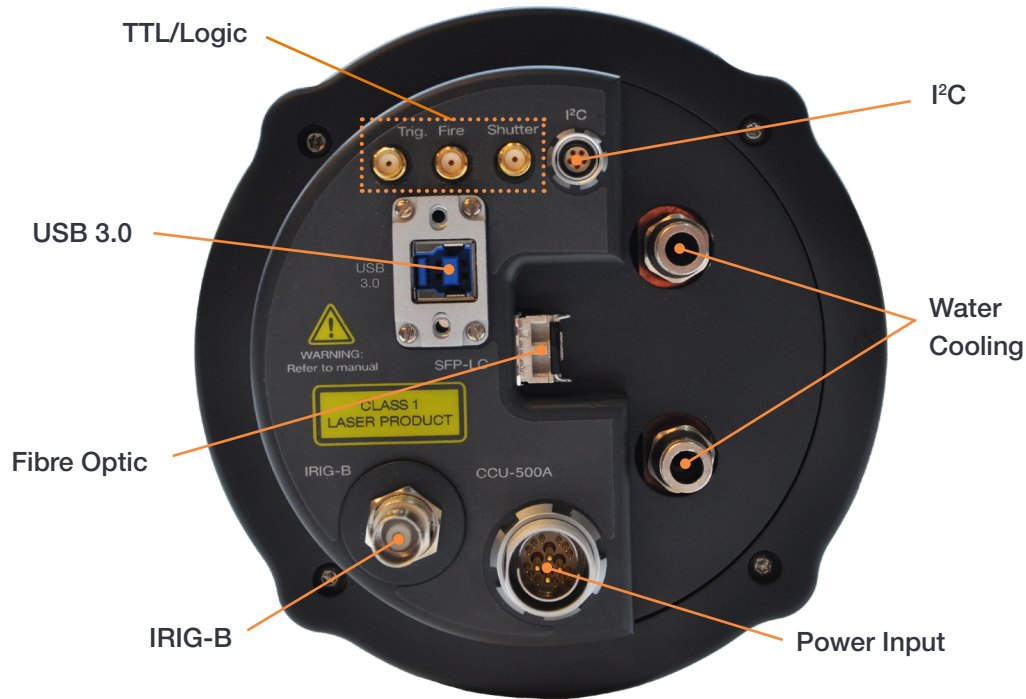

Connects the iKon-XL to the control PC USB 3 card via a high speed USB 3.0 connection.

### TTL / Logic

The TTL/Logic connection permit connection to other devices for synchronisation and control of fire, trigger and shutter operations. Connector type: SMA, provided with SMA - BNC cable Fire (Output), External Trigger (Input), Shutter (Output).

### Input & Output Timing Hardware

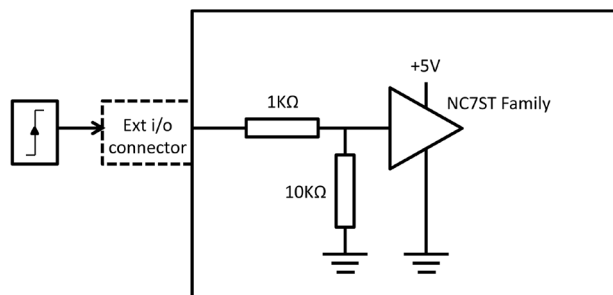

- VIH (High level input voltage): 2.2 V (min) to 5 V (max)
- VIL (Low level input voltage): 0.88 V (min)

### External Trigger Input (at connector)

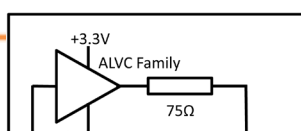

- Fire, Shutter, Arm and Frame Output (at connector)
- Use 50  $\Omega$  cable and high impedance input (>1k $\Omega$ )
- Drive both TTL and CMOS unterminated input

## I<sup>2</sup>C

The I<sup>2</sup>C provides a connection option via the I<sup>2</sup>C interface. Compatible with Fischer type SC102A054-130 connector. (1) Shutter (TTL), (2) I<sup>2</sup>C Clock, (3) I<sup>2</sup>C Data, (4) +5 Vdc, (5) Ground.

## Fibre Optic

The LC fibre-optic I/O connection provides a convenient connection over longer distances: 15 m as standard (25 m and 100 m options are also available from Andor). Note that the fibre is the multimode (MM) type.

## IRIG-B

The iRIG-B connection is compatible with IRIG-B standard (GPS with 10 ms resolution). The iRIG info is only stored in the IRIGDATA field and is retrieved from an independent time source – it does not have any bearing on the DATE or FRAME fields whose data is from the PC. The table of IRIG data is available from FITS files.

## Liquid Cooling Connections (liquid cooled models only)

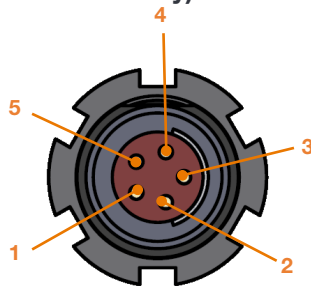

Liquid cooling connections provide the facility for connection to recirculator or other water/liquid cooling system. Refer to **Section 3.7**.

## Power

Power input connection for connection to the CCU-500. Refer to **Section 2.3**.

## Notes:

Minimum cable clearance required at rear of camera 150 mm.

## 2.3 CAMERA CONTROL UNIT (CCU-500)

The Camera Control Unit provides control functions and a stable DC power supply for the iKon-XL.

**CCU-500A** Supplied with the iKon-XL **Flexi-cooling Model**

**CCU-500B** Supplied with the iKon-XL **Deep Cooled Model**

Figure 4: The CCU-500 Camera Control Unit (front View)

## Display Diagnostics

Switch display lights on or off. Switching the diagnostic lights off may be useful if background light levels must be minimised.

### Output Good

This LED (green) indicates that the power status of the CCU-500 is within normal parameters.

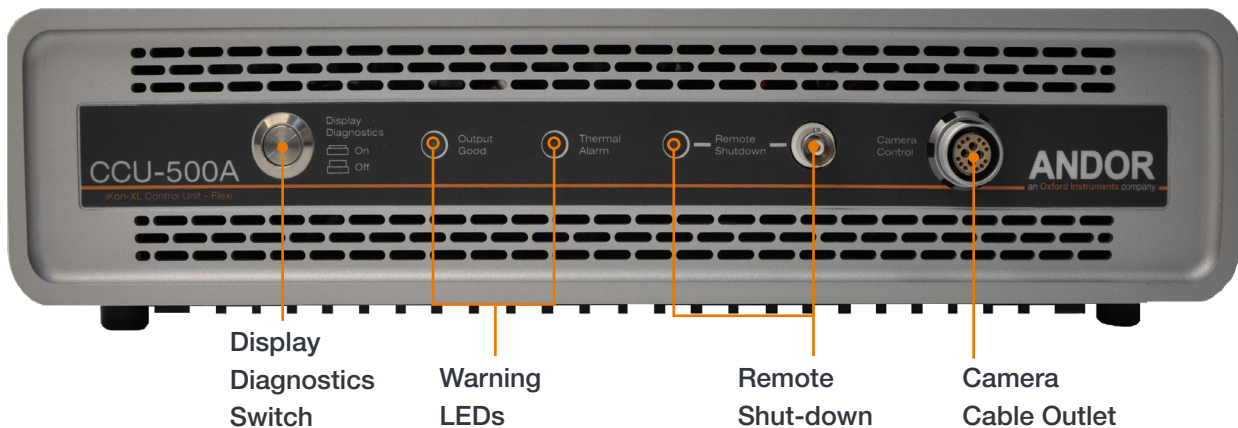

### Thermal Alarm

This LED (red) illuminates to warn the user if the CCU-500 unit overheats e.g. due to obstruction to the cooling fans, or if there is a fan failure.

### Remote Shutdown

Enables remote power on/off using a cable with BNC connection. The LED (orange) illuminates if the unit has been remotely powered down (Note there is no indication of power status in Solis).

- CCU-500 On: Open-circuit (or logic 0).
- CCU-500 Off: User must supply drive TTL logic high +2.4 V at 10 mA to powerdown the CCU-500.

### Camera Cable Outlet

A camera control cable connects the CCU-500 to the iKon-XL camera. The standard supplied cable is 5 metres long- if the CCU-500 is to be situated at a longer distance (15 m options available) this must be specified at time of ordering as the CCU-500 must be configured for the cable used.

Figure 5: The CCU-500 Camera Control Unit (Rear View)

### Power Input (& Power Switch)

There is a switched power input (I= on, O= Off) from the mains AC supply to the CCU-500. Note that there are fuses in the line input (see Section 5.5 for details and replacement procedure).

### Fans

3 fans provide cooling to the unit- ensure that there is sufficient space at the front and rear of the unit for unrestricted air flow (minimum 100 mm).



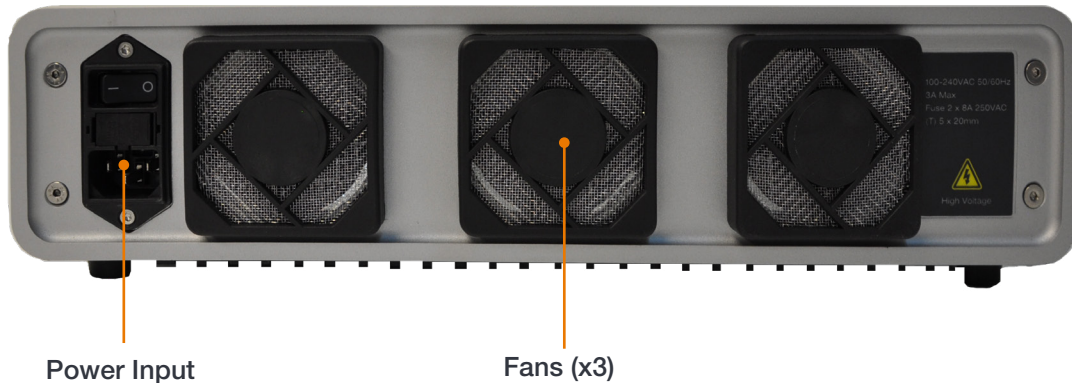

## 2.4 POWER REQUIREMENTS

Ensure that the power connector for the iKon-XL camera is inserted securely. The connector is keyed to aid correct orientation. Refer to technical specifications for power supply requirements.

### NOTES:

1. The electrical mains lead should be certified for use in your country and in applicable countries the plug must be fitted with a 240V 5A fuse.
2. The iKon-XL is designed to use the CCU-500 camera control unit for power and signal operations. If users use any other power supply, they do so at their own risk.

## SECTION 3: INSTALLATION

### WARNINGS:

- **PRIOR TO COMMENCING INSTALLATION, THE USER SHOULD REFER TO THE SAFETY AND WARNING INFORMATION AND UNPACKING INSTRUCTIONS AT THE BEGINNING OF THIS MANUAL.**
- **THE IKON-XL WEIGHS ~8-12 KGS (~18-26 LBS). DUE CARE MUST BE TAKEN WHEN LIFTING THE CAMERA. ENSURE THAT THE MOUNTING AND CONNECTED ASSEMBLY IS SECURE AND ABLE TO SUPPORT THE WEIGHT OF THE CAMERA.**
- **POWER CABLING AND CONTROL CABLES SHOULD BE ROUTED TO PREVENT ACCIDENTS, DAMAGE AND ACCIDENTAL UNPLUGGING; AVOID BEND RADII OF LESS THAN 30 MM AND ENSURE THERE IS ADEQUATE CABLE STRAIN RELIEF FOR THE CONNECTORS.**

- ~~THE CCU-500 IS CONFIGURED AT THE FACTORY FOR THE LENGTH OF CABLE USED TO CONNECT IT TO THE IKON-XL. IF A CCU-500 CONFIGURED FOR 15 M CABLE IS CONNECTED TO A CAMERA USING A 5 M CABLE THE CAMERA WILL BE DAMAGED.~~
- TEMPERATURE AND HUMIDITY MUST MEET THE SPECIFICATIONS DEFINED IN TECHNICAL SPECIFICATIONS.

### 3.1 TRANSPORT AND STORAGE INFORMATION

- The iKon-XL is packed in a normal transport packaging for shipping. Hard shell transport cases are available for the iKon-XL for convenient and safe transport of the iKon-XL to and from the installation site e.g. observatory.
- Allow the product to reach the ambient temperature after unpacking- especially if moving from a colder environment to a warm environment as this may lead to condensation (see Section 6.1 for further information).

#### Storage

- Storage Temperature: -30°C to 50°C.
- If it is to be stored after use at a temperature below the coolant freezing point, ensure that all liquid coolant has been expelled from the camera.

### 3.2 MOUNTING THE IKON XL USING THE MOUNTING FLANGE

The iKon-XL mounting flange features 8 off M5 tapped holes x20 deep on a 189 PCD. These can be used to secure the iKon-XL to the mounting plate of the telescope or other optical system.

### 3.3 ATTACHING TO MOUNTING POSTS

**Deep Cooled model:** Four sets of 2x ¼ -20 UNC mounting holes at 90° intervals on a 189 PCD  
**Flexi-cooling model:** Four sets of 1x ¼ -20 UNC mounting holes at 90° intervals on a 189 PCD  
 For further information, refer to the mechanical drawings in **Appendix**

### 3.4 INSTALLING THE CCU-500 CAMERA CONTROL UNIT

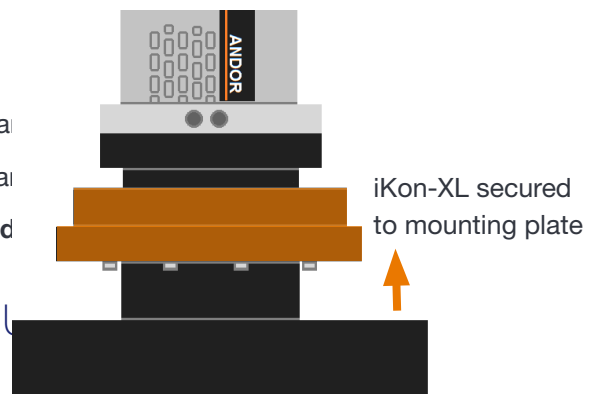
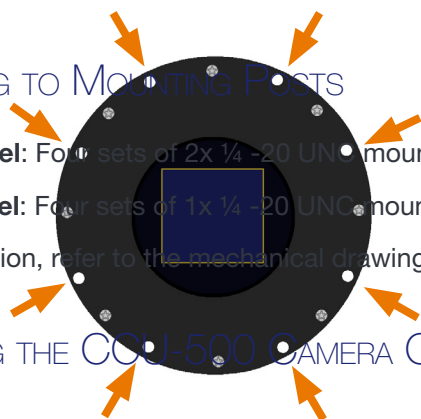

The Camera Control Unit may be mounted in a 19" rack mount with the supplied rack mount brackets (x2) and 6 off M5 x 10 csk screws:

on a flat level platform with the supplied feet (x4):

or an optical table using the CCU-500 mounting lugs and 6 off M5 x 10 csk screws:

**WARNING: Ensure that the rear fan outlets are not obstructed so that the unit is adequately ventilated.**

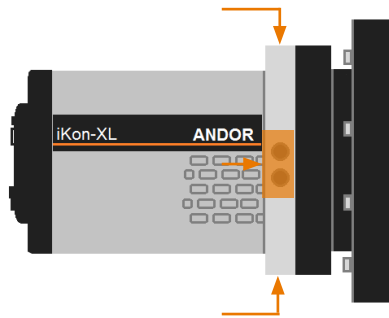

### 3.5 CONNECTING THE iKON-XL TO THE PC

The appropriate PCIe card should be installed in the PC for either USB 3.0 cable or fibre optic connection.



#### USB 3.0



- Connect the USB 3.0 cable from the iKon-XL to a suitable USB 3.0 slot on the control PC.



### Fibre Optic

- Connect the fibre optic cable from the iKon-XL to the fibre optic input of the PCIe card of the control PC.
- Always ensure that the fibre optic cable is installed before switching on the camera.
- Fibres can easily be damaged by bending or general mishandling. Take care when routing cables to avoid tight bends and strain on the connections. Refer to further handling guidelines in the preface of this manual.

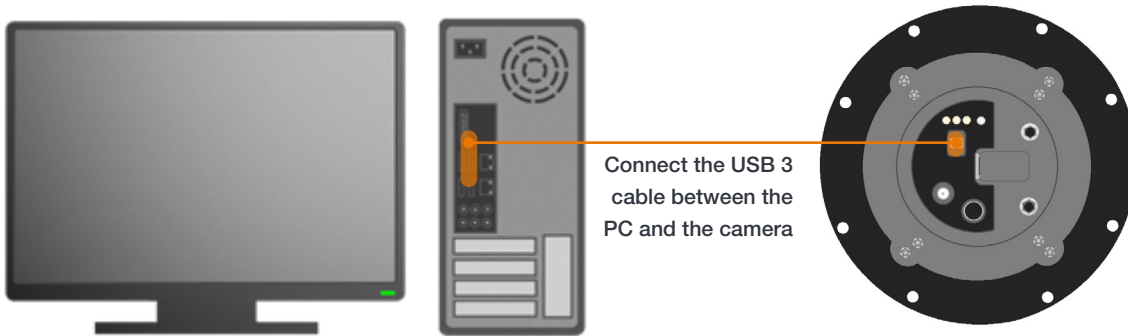

### 3.6 CONNECTING THE iKON-XL TO THE CAMERA CONTROL UNIT AND POWER SUPPLY

- Connect the power cable (front panel) between the CCU-500 and the Camera power input (rear panel).
- Connect the mains power cable between the CCU-500 power input (rear panel) and the mains power supply.

#### WARNING

The CCU-500 must be configured at the factory for the length of cable. If the CCU-500 has been configured for 15 m cable and a longer cable is connected to a camera using

the iKon-XL. If a CCU-500 is connected to a camera using a longer cable, the camera may be damaged.

#### Notes:

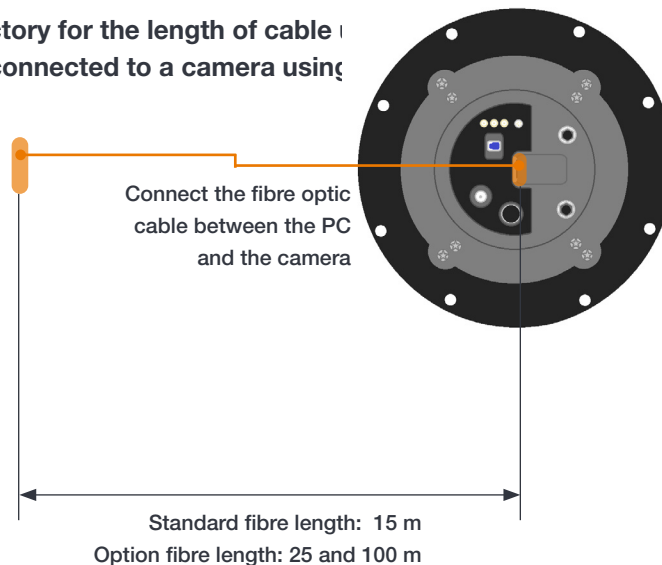

- The CCU-500A is supplied with the iKon-XL flexi cooling model; CCU-500B is supplied with the deep cooled model.
- Route the cable to avoid tight bends or strain on the cable connections.
- If you need a replacement cable please contact your Andor representative with details of your camera, CCU-500 model and cable length so the correct camera can be supplied.



Connect to the mains power supply (rear panel)

Connect the camera power cable between the CCU-500 power output and the Camera power input

- For connector and pin-out information please refer to **Technical Specifications**



Use the alignment guides (orange dots)



## 3.7 CONNECTING A COOLING SYSTEM

The iKon-XL Flexi-cooling model can use either air cooling, or optional liquid cooling.

The iKon-XL Deep Cooled model *must* be connected to a liquid cooling system.

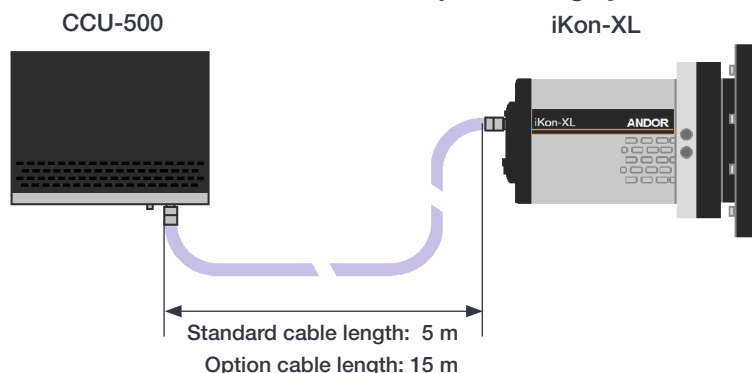

### 3.7.1 IMPORTANT CONSIDERATIONS WHEN USING LIQUID COOLING SYSTEMS

- Before attempting to insert or remove the coolant hose connections, ensure that all coolant has been drained from the hoses and integral coolant channel within the camera head.
- Care must be taken to avoid permanent damage to the camera system resulting from either leakage of coolant during connection/removal of hoses or spillage of any residual coolant contained within the camera head once the hoses have been removed.





- Always ensure that the temperature of the liquid coolant circulated through the camera head is above the dew point of the camera ambient temperature and humidity conditions. Refer to the Dew Point graph in **Appendix C** for guidance.
  - Use of coolant at or below the dew point can result in permanent damage to the camera head, due to formation of condensation on internal components.
  - Never use damaged, split or worn hoses.
- **The water cooling system of the camera is rated to 6 bar (600 kPa). If your water supply exceeds this value, then an overpressure safety device or regulator must be fitted to restrict the water pressure to less than or equal to this rating.**
- In the event that replacement hose inserts/barbs are required, please contact your local Andor representative.
- Always remove residual coolant from the camera head if the camera is to be stored after operation—especially if the storage conditions are below the freezing point of the coolant.

### 3.7.2 COOLING HOSE CONNECTORS

There are two cooling hose connectors (replacement part # MSC-10390) located on the rear plate for the connection of the iKon-XL to a water cooler, or re-circulator system.



Hose inserts are provided to enable connection to coolant hoses.

- **Coolant Hose Connectors:** Two barbed coolant hose inserts (replacement part # MSC-06489) are supplied as standard, suitable for connection to 6 mm [0.25"] internal diameter soft PVC tubing / hose.
- **Recommended tubing:** 10 mm [0.4"] outside diameter, i.e. a wall thickness of 2 mm [0.08"]. Alternative hose dimensions and materials should be thoroughly tested to ensure a leak tight seal is achieved with the barbed inserts.

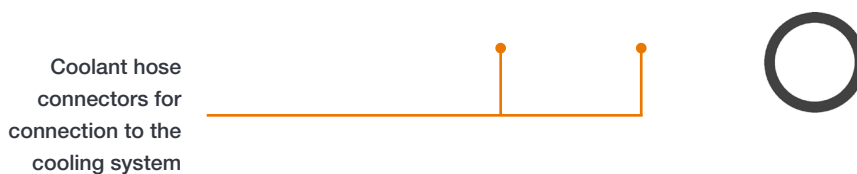

### 3.8 COOLANT RECOMMENDATIONS

- **Coolant temperature:** Refer to the temperatures specified in Technical Specifications. Note that cooling performance may be affected by distance between camera head and cooler.
- **Recommended coolant:** water or water/glycol mix depending on the ambient environmental temperature during operation.

De-ionized water (without additives) may be used as the coolant. Some mains supply water is heavily mineralized (i.e. “Hard”) which could cause deposits in the water circuit inside the camera. This can reduce the flow-rate and cooling efficiency. The specified cooling performance of the camera can be achieved with coolant flow rates of 2 litres per minute, the maximum recommended pressure of coolant circulating through the camera head is 2 bar (30 PSI).

**NOTE: The water cooling system is rated to 6 bar (600 kPa). If your water supply exceeds this**

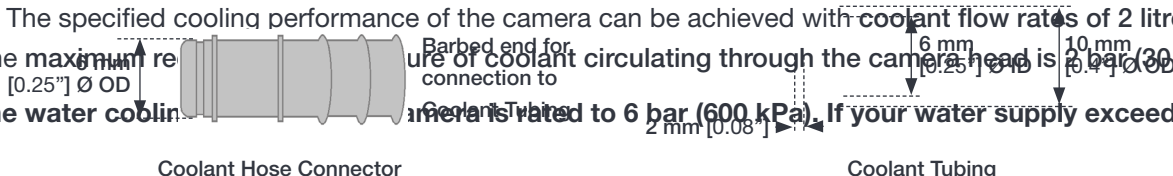

value, then an overpressure safety device or regulator must be fitted to restrict the water pressure to less than or equal to this rating.

### 3.9 CONNECTING THE LIQUID COOLING SYSTEM

An overview for connecting a liquid cooling system is outlined below- please refer to the information supplied with your cooling system for further information.

#### 3.9.1 CONNECTING THE COOLANT HOSES

1. Press the hose insert into the coolant hose, and repeat for the second hose.
2. Press the hose connectors into the connections on the camera head, ensure they click into place.
3. Confirm the hoses are connected securely by applying pressure on the front of the camera body and pulling backwards on each hose.
4. Connect the other ends of the coolant hoses to the cooling system- refer to the cooling system manual.

#### 3.9.2 DISCONNECTING THE COOLANT HOSES

1. Press the latch on the camera hose connection away from the hose.

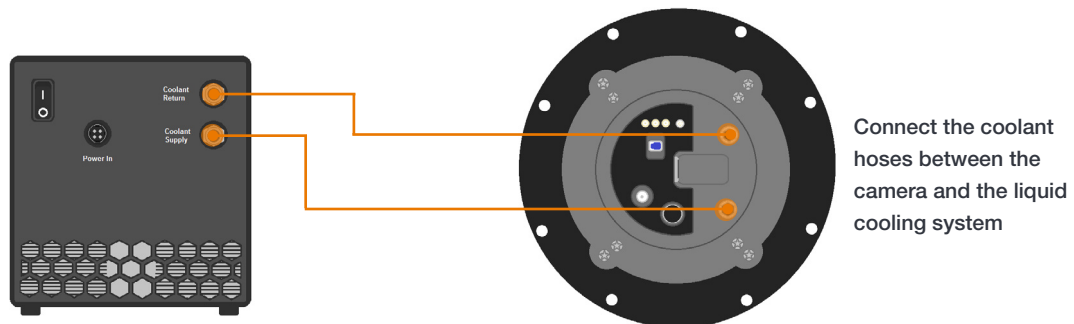

2. Hold the latch in and pull the hose backwards.
3. The hose should release from the camera connection with little resistance.



**NOTE:** If the hose does not release, ensure that the latch on the camera connection is pressed in fully.



### 3.10 INSTALLING SOFTWARE AND USB DRIVERS

Please note, you must have administrator access to do the following procedures.

#### 3.10.1 MINIMUM COMPUTER REQUIREMENTS

- 3.0 GHz single core or 2.4 GHz dual or quad core processor
- 2 GB RAM
- 100 MB free hard disc to install software (at least 1 GB recommended for data spooling)
- USB 3.0 High Speed host Controller capable of sustained rate of 60 MB/s

- Windows (7, 8, 8.1 and 10) or Linux

### 3.10.2 INSTALLING SOLIS SOFTWARE AND USB DRIVERS

#### Windows:

Switch on the PC, insert the CD (or access the download location) and run the setup exe e.g AndorSDKSetup-  
<version>.exe

1. Confirm the version of software.
2. Follow the on screen prompts.
3. Select the installation directory when prompted.
4. If prompted for camera type select iKon-XL
5. On the final window click on “Install”. Continue to follow the on screen prompts.
6. To complete the installation, when prompted select “Yes, restart the computer now” and click on the finish button.

#### Linux:

1. Switch on the PC, then unpack the archive that you have received. In the following steps replace <version> with the version number of the archive you have. E.g. 2.102.30000.0
2. Open a terminal.
3. Change the directory to where the andor-<version>.tar.gz file is located.
4. Type “tar -zxvf andor-<version>.tar.gz”.
5. A new directory named “andor” is created.
6. To install the SDK run the script “install\_andor” from the andor directory and follow the on screen prompts. (See the INSTALL file located in the same directory for further information).

### 3.10.3 NEW HARDWARE WIZARD (WINDOWS)

When the iKon-XL camera is connected to a PC for the first time, the **New Hardware Wizard** screen will appear.

1. Select the ‘**No, not this time only**’ option then click **Next>**.
2. Select the ‘**Install from a list or specified location (Advanced)**’ option then click **Next>**.
3. Navigate to the directory where the Andor Solis software was installed to on the PC, then click **Next>** so that **the Installation Wizard can start**.
4. Click the **Finish** button to complete the installation.

**Note: If the camera is connected to a different USB port, steps 1 – 4 will have to be repeated on the first connection only.**

5. A system message will appear to indicate that the device has been successfully installed.

Note: You can check that the iKon-XL is correctly recognized and installed by opening the Device Manager (Devices and printers) in Windows, Control Panel. The iKon-XL will show under the Devices list.

### 3.11 INSTALLING A USB 3.0 CARD (IF REQUIRED)



**Ensure anti-static precautions using anti-static strap provided. Keep all screws safe.**

1. Ensure both the camera and PC are turned off.
2. Unplug all cables from the rear of the computer.

3. Open the PC enclosure to gain access to the expansion slots.
4. Locate a suitable PCIe slot for the **USB 3.0** card: a PCIe slot greater than or equal to x4 is needed (*If you are unsure which slot is correct, please consult the PC user manual*).
5. Remove the filler bracket corresponding to the slot you intend to use.
6. Remove the PCIe card carefully from its protective ESD packaging and insert the card connector fully into the expansion slot.
7. Ensure the card's mounting bracket is flush with any other mounting or filler brackets to either side of it, then secure the controller card in place.
8. Fit the computer cover and any accessories that you were using previously.
9. Carefully fit the USB 3 cable between the camera and the PC.

### 3.11.1 DISABLING POWER MANAGEMENT FOR THE USB 3.0 HOST CONTROLLER

1. Navigate to '**USB 3.0 Host Controller**' properties menu in **Device Manager** (Control Panel>Device Manager>Universal Serial Bus Controllers).
2. Select the **Advanced** tab.
3. Check the **Disable USB 3.0 power management functions** check-box.

### 3.12 INSTALLING A FIBRE OPTIC CARD



**Ensure anti-static precautions using anti-static strap provided. Keep all screws safe.**

**It is highly recommended to use the fibre optic card supplied by Andor to ensure reliable operation. Please contact your andor representative for further information if required**

**Take care that the fibre optic cable has adequate strain relief/support at the connection and that the routing avoids tight radii. Refer also to the Working with Optical fibres section in the preface of this manual for further guidelines.**

1. Ensure both the camera and PC are turned off.
2. Unplug all cables from the rear of the computer.
3. Open the PC enclosure to gain access to the expansion slots.
4. Locate a suitable PCIe slot for either fibre optic or USB 3.0 cards: x4, x8 x16 PCIe recommended. *Note that x1 slots may be shared with other devices resulting in reduced system performance. If you are unsure which slot is correct, please consult the PC user manual.*
5. Remove the filler bracket corresponding to the slot you intend to use.
6. Remove the PCIe card carefully from its protective ESD packaging and insert the card connector fully into the expansion slot.
7. Ensure the card's mounting bracket is flush with any other mounting or filler brackets to either side of it, then secure the controller card in place.
8. Fit the computer cover and any accessories that you were using previously.
9. Carefully connect the fibre optic cable between the fibre optic card and the fibre optic port on the rear plate of the camera.
10. Turn on the camera, once the double beep is heard, THEN turn on the PC. **Note: The light on back of the fibre optic card should now be green.**

#### 3.12.1 INSTALLING FIBRE OPTIC CARD DRIVERS (WINDOWS ONLY)

**The Fibre Optic Adapter card driver is pre-installed with Windows 10, however it is still recommended to install the supplied driver versions. Drivers (for windows 7, 8, 8.1 and 10) should be installed as follows:**

1. On the supplied software CD navigate to the fibre optic card drivers e.g.:

Texas\_Instruments\_xHCI\_Driver\_v1.16.4.0\_WHQL\_(Multilanguage) and run the Texas\_Instruments\_xHCI\_Driver\_v1.16.4.0\_WHQL\_(Multilanguage).exe.

**Note:** Select the appropriate driver to match the OS of the control PC e.g. Windows, 7, 8, 8.1 or 10. File locations and versions may differ from those shown in this example.

2. Follow the on screen instructions of the install wizard.
3. If successfully installed the device should show up as “Texas Instruments USB Root Hub”.

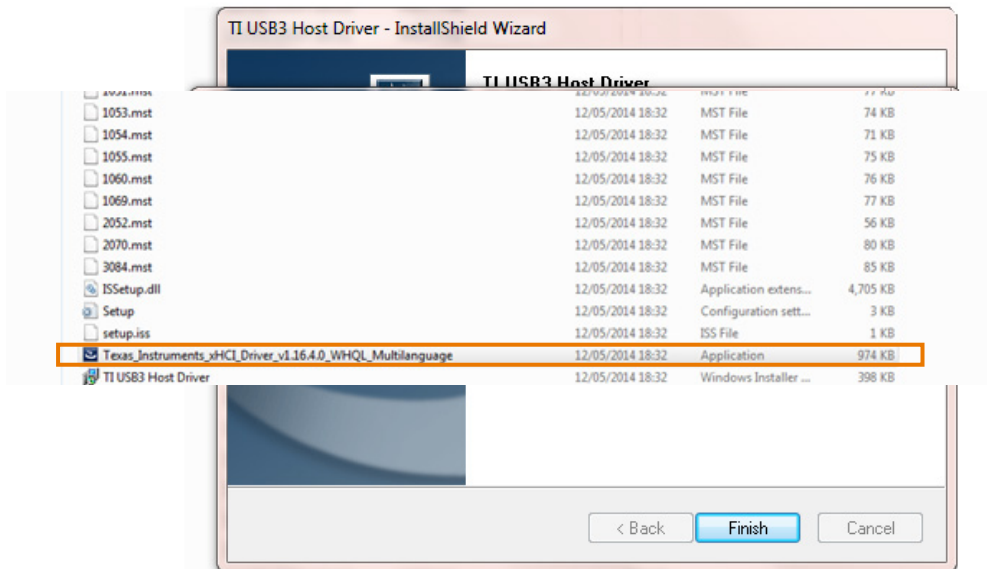

4. Launch “Andor Solis”, the software should automatically detect the camera. The camera should now be ready to use.

## SECTION 4: OPERATION

### WARNINGS:

- **IF THE EQUIPMENT IS USED IN A MANNER NOT SPECIFIED BY ANDOR OR ITS DISTRIBUTORS, THE PROTECTION PROVIDED BY THE EQUIPMENT MAY BE IMPAIRED.**
- **PLEASE READ THE USER GUIDES SUPPLIED WITH YOUR SYSTEM COMPONENTS AND CAMERA CONTROL SOFTWARE PRIOR TO USE.**

### 4.1 EMERGENCY MAINS DISCONNECTION

In case of emergency, the disconnecting point of the equipment is the mains power cord connected to the external power supply, or the mains socket switch. There is also a switch at the rear of the CCU-500 (See Section 2.3).

**WARNING: SWITCH OFF THE POWER AT THE MAINS SOCKET AND REMOVE THE MAINS LEAD FROM THE EXTERNAL POWER SUPPLY.**



## 4.2 POWER-UP SEQUENCE

---

1. Ensure that the iKon-XL is powered on at the CCU-500 and at the mains power supply.
2. Ensure that the USB 3.0 (Section 3.11) or fibre optic cable (Section 3.12) is connected between the camera and the PC.
3. Start up the PC after the camera.
4. Launch your camera control software e.g. Solis or SDK2
5. The camera will now start up under control of the software and you are ready to use the camera.
6. Refer to your software manual for set-up and image acquisition information.

## 4.3 POWER-DOWN SEQUENCE

1. Exit the camera control software.
2. The camera will automatically turn off.
3. Switch off power to the camera at the CCU-500 and if not using for some time, switch off and disconnect from the mains power socket.

## 4.4 USING THE iKON-XL

Once set-up the iKon-XL is controlled through the camera control software. Please refer to the information supplied with the camera control software (available separately) for further details e.g. **Andor Solis** or **SDK2**. For information on the features available with the iKon-XL please refer to the **Appendix D Reference Information**.

# SECTION 5: MAINTENANCE



**THERE ARE NO USER-SERVICEABLE PARTS INSIDE THE CAMERA. DAMAGE CAUSED BY UNAUTHORISED MAINTENANCE OR PROCEDURES WILL INVALIDATE THE WARRANTY.**

## 5.1 REGULAR CHECKS

- The state of the product should be checked regularly, especially the integrity of the CCU-500 and the mains cable.
- Do not use equipment that is damaged.

## 5.2 ANNUAL ELECTRICAL SAFETY CHECKS

- It is advisable to check the integrity of the insulation and protective earth of the CCU-500 on an annual basis, e.g. U.K. PAT testing.

- Do not use equipment that is damaged.

### 5.3 GENERAL CLEANING & DECONTAMINATION INFORMATION

- The camera body can be cleaned with a soft cloth and dampened by water or glass cleaner.
- Never spray liquids directly on the camera; apply cleaning solution to the cloth, then wipe the camera body with the dampened cloth.
- Do not use abrasive or other detergents to clean the camera.
- Dust may also collect on the cooling fans located on the back of the CCU-500. From time to time, it may be necessary to clear away the dust with a small brush. The fans disperse heat from the unit. Should the airflow become blocked, the unit may overheat and the thermal warning will be activated to protect the unit from damage.
- Decontamination: In the event any product must be returned the customer must complete a decontamination form to declare the equipment as contamination free and safe for Andor employees to work on: <http://www.andor.com/decontamination.aspx>.

### 5.4 CLEANING THE CAMERA WINDOW



At some point, it may become necessary to clean debris that may have settled on the CCD imaging sensor window. Cleaning the camera window can provide effective results providing you carefully follow these step-by-step directions.

#### WARNINGS

- **Only open the shutter (if present) using camera control software.**
- **Do not attempt to manually open the shutter with your fingers or other objects.**
- **The glass is located very close to the CCD imaging sensor. Scratching the window may require the window to be replaced.**
- **Cleaning the window is done entirely at the customer's risk, window replacement is not covered under the warranty. It's better to under-clean than to over-clean.**

#### 5.4.1 TOOLS REQUIRED

- Compressed Air Can (or source of clean compressed air)
- Optics Brush

#### 5.4.2 WINDOW CLEANING PROCEDURE

1. Remove the camera from your telescope (or other optical equipment) and place it on a clean dry surface.
2. Use the camera control software to open the shutter (if fitted).

**TIP:** If your program does not have this feature, try starting a long exposure. Over exposing the CCD to room light will not damage the CCD.

### Guidelines for using Compressed Air

- **If you are using a compressed air can always test-blast away from window before blowing air on the window. When you test-blast, you'll notice a spray of condensation shoot out from the can.**
  - **If condensation does form on the window, do not wipe it off. Allow it to fully dry before proceeding.**
  - **Always orient the compressed air can in an upright position before spraying.**
  - **A clean source of compressed air such as an can is recommended- do not use a compressor that may spray fine droplets of oil, or an unfiltered air supply that may spray dust particles onto the camera window.**
3. With the shutter open, turn the camera on its side making it easier for particles to fall out of the camera head Face the window toward you at the edge of a table.
  4. Give the window short blasts of compressed air to work dust particles out of the camera head.
  5. If there are still particles stuck on the window use an optics brush to very carefully dislodge them from the window surface. Then spray the dust particles out of the camera head with compressed air.
  6. Make sure to use compressed air to clean your adapter tubes and focal reducers as well so you don't get more dust once everything's assembled.

## 5.5 FUSE REPLACEMENT

### CCU-500

The CCU-500 has 2 in-line fuses fitted to the power input in a fuse holder cartridge. Only replace with fuse of the same type and rating for continued protection. The characteristics of the replacement fuses are as follows:

CCU-500A	CCU-500B
<b>Rating:</b> 2 x 3.15A 250 VAC	<b>Rating:</b> 2 x 8A 250 VAC
<b>Type:</b> (T) 5 x 20 mm	<b>Type:</b> (T) 5 x 20 mm

If the fuses need replaced, disconnect the unit from the mains supply and remove the mains power cord from the power input socket to access the fuse holder. A flat slotted object (e.g. slot headed screwdriver) can then be used to remove the fuse holder and replace the fuses.

In the U.K, Ireland and some other countries, the supplied mains cable has a BS 1363 (or Type G) plug that includes an integrated fuse. Only replace with fuse of the same type and rating for continued protection. The characteristics of a replacement fuse are as follows:

- **Rating:** 5A 240 VAC
- **Type:** BS 1362, size: ¼ x 1" (6.3 x 25.4 mm) cartridge

## 5.6 REPLACEMENT OF THE SHUTTER

The mechanical shutter (where fitted) may be replaced by the user if this is required. For a replacement shutter (models shown in Section 1.5.3) and information on the replacement procedure please contact your Andor representative.

## 5.7 COOLING HOSES AND CONNECTIONS

The user should routinely check all cooling hoses and connections for signs of leakage, damage or wear. All seals must be intact before powering on camera system and any worn/damaged items must be replaced immediately.

## 5.8 CCU-500 COOLING FANS

The cooling fans of the CCU-500 disperse heat from the unit and must be inspected periodically to ensure they are flowing freely (Section 5.3). If a fan fails please contact your Andor representative for further information.

# SECTION 6: TROUBLESHOOTING



## 6.1 PREVENTING CONDENSATION

### Key Risks

- Take special care during installation as the temperature of the camera may be low from shipping or storage. When moved to a warmer environment such as a lab, there is a higher risk of condensation forming. Therefore, ensure that sufficient time is allowed for the product to reach the ambient temperature of the operating environment before use (this may take several hours).



- Never use water that has been chilled below the dew point of the ambient environment to cool the camera.

### How may Condensation be detected?

You may see condensation on the outside of the camera body if the cooling water is at too low a temperature or if the water flow is too high. The first signs of condensation will usually be visible around the connectors where the water tubes are attached. If this occurs carry out the following actions:



1. Switch off the system

- Wipe the camera with a soft, dry cloth.

**NOTE: It is likely there will already be condensation on the cooling block and cooling fins inside the camera.**

- Set the camera aside to dry for several hours before you attempt reuse.
- Before reuse blow dry gas through the cooling slits on the side of the camera to remove any residual moisture.

Use warmer water or reduce the flow of water when you start using the device again.

**NOTE: This is not an issue when using a Re-circulator which eliminates the dew point problem.**

Refer to Appendix C for a Dew Point Graph.

## 6.2 QUICK TROUBLESHOOTING GUIDE

Issue	Possible Cause	Action
Thermal Warning Light LED illuminated on CCU-500	Fans obstructed	Check fans at rear of unit are not obstructed and free of dust. Remove any obstruction or dust.
	Fan not working	Check fans rotate. Contact Andor customer support if a replacement is required.
Output Good LED does not illuminate on CCU-500 after switching on	Power not received from mains supply	Check that mains power is ON and meets power supply specifications outlined in Technical Specifications. Check power switch at rear of CCU-500 is ON. Check fuses in CCU-500 and mains power plug (if fused type)
	Display Diagnostics is OFF	Check that the display diagnostics button is set to ON so LEDs illuminate.
Camera start-up tone does not sound on start-up	Camera not receiving power	Check cable is connected between camera and CCU-500. Check power status of CCU-500. Check CCU-500 is receiving power from the mains supply.

## APPENDIX A: TECHNICAL SPECIFICATIONS

### iKon-XL 230 Sensor Models

Sensor Options	See Section 1.5.1
Pixels	4096 (H) x 4108 (V)
Pixel size	15 x 15 $\mu\text{m}$
Image area	61.4 x 61.4 mm with 100% fill factor
Active area pixel well depth (typical)	150,000 e <sup>-</sup>
Pixel readout rates	0.1, 1, 2, 4 MHz
Peak QE	>95% for BV models >87% for BB models



## iKon-XL 231 Sensor Models

<b>Sensor Options</b>	See Section 1.5.1
<b>Pixels</b>	4096 (H) x 4108 (V)
<b>Pixel size</b>	15 x 15 $\mu\text{m}$
<b>Image area</b>	61.4 x 61.7 mm with 100% fill factor
<b>Active area pixel well depth (typical)</b>	350,000 e <sup>-</sup>
<b>Pixel readout rates</b>	0.1, 0.5, 1, 3 MHz
<b>Peak QE</b>	>95% for BV models, >90% for BEX2, BR-DD and BEX2-DD models, >87% for BB models

Note: Refer to the [iKon-XL Specification Sheet](#) for full specifications.

## General Specifications

<b>Minimum temperatures</b> @ coolant temperature of 10°C @ coolant temperature of 16°C air cooled	<b>Deep Cooled Model</b>	<b>Flexi Model</b>
	-100°C	-80°C
	-95°C	-70°C
	N/A	-60°C
<b>Blemish specification</b>	Grade 1 or higher, as per manufacturers definition	
<b>System window type</b>	Single AR coated UV grade fused silica window (>98% transmission)	

<b>Binning</b>	User definable
<b>Region of Interest (windowing mode)</b>	User definable (centred in 4-output mode)
<b>Digitization</b>	16-bit (all speeds) 18-bit** **refer to Appendix D
<b>Outputs</b>	Quad or Single
<b>Timestamp</b>	iRig-B GPS with 10 ms resolution

<b>Weight</b>	<p><b>iKon XL</b></p> <p>Flexi-cooling: 8.25 Kg [18 lbs 3]          Deep Cooled: 12 Kg [26 lbs 7]</p> <p><b>CCU-500</b></p> <p>6.6 Kg [14 lbs 5] (approx)</p>
<b>Dimensions mm [inches] W x H x D</b>	<p><b>iKon XL</b></p> <p>Flexi-cooling: 200.0 x 200.0 x 277.3 [7.87" x 7.87" x 10.92"]          Deep Cooled: 200.0 x 200.0 x 266.3 [7.87" x 7.87" x 10.48"]</p> <p><b>CCU-500</b></p> <p>370.0 x 284.2 x 92.8 [14.57" x 11.19" x 3.65" ]</p>

## Environmental Specifications

<b>Usage</b>	Indoor or Observatory use
<b>Operating Altitude</b>	Up to 6000 m
<b>Operating Temperature</b>	0°C to 30 °C ambient (using standard Shutter) -30°C to +30°C ambient (using extended temperature range shutter)
<b>Storage Temperature</b>	-30°C to 50 °C
<b>Operating Relative Humidity</b>	<70% (non-condensing)
<b>Ingress Protection</b>	IP20
<b>Overvoltage Category</b>	CAT II. An overvoltage category of CAT II means that the equipment is designed to cope with transient voltages above the rated supply that would be experienced by any product connected to a mains socket in a building.
<b>Rated Pollution</b>	Pollution Degree 2. Normally only non-conductive pollution occurs. Occasionally, however, a temporary conductivity caused by condensation must be expected.
<b>Ventilation Requirements</b>	<p><b>iKon-XL</b></p> <p>Flexi model only: Ensure that ventilation slots are not obstructed when in air cooled mode.</p> <p><b>CCU-500</b></p> <p>Ensure that ventilation slots for the 3 fans on the rear panel are not obstructed.</p>

## Power Requirements

The iKon-XL has been designed for use specifically with the CCU-500 camera control unit which integrates power and camera control functions in one unit. Power supply, consumption and signal information is provided below:

<b>CCU-500 Mains Input</b>	<p>100-240 V AC 50/60 Hz</p> <p>2A max. (flexi-cooled models)</p> <p>5.33A max. (deep cooled models)</p>
<b>Low Voltage/Current Outputs</b>	<p>+39V 80mA</p> <p>+15V 2A</p> <p>+8V 290mA</p> <p>-8V 400mA</p> <p>Shutter Drive 24V 1.2A 100ms pulse and 0.3A hold current.</p>
<b>Low Voltage Output Connector of CCU-500</b>	<p>Fischer DBP 105 A110-139 (CCU-500A)</p> <p>Fischer DBP 105 A110-239 (CCU-500B)</p>
<b>Low Voltage Input Connector of iKon-XL</b>	<p>Fischer DBP 105 Z110-139 (CCU-500A)</p> <p>Fischer DBP 105 Z110-239 (CCU-500B)</p>

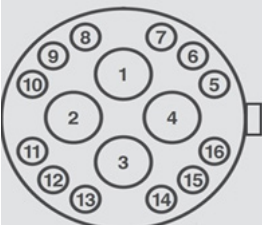
Camera Control Cable pin-outs	Pin Number and Description
<p><b>Power Consumption</b></p> 	<p><b>Flexi-cooling Model (single cooler)</b></p> <p>Camera Head + CCU-500, 240V/100V (Typ.): 165/180 W            Camera Head Only (Typ./ Max.): 133/135 W</p> <p><b>Deep cooled Model</b></p> <p>Camera Head + CCU-500, 240V/100V(Typ): 465/480 W            Camera Head Only (Typ./ Max.): 433/435 W</p>

Camera End (Male)  
DBP 105 Z110-139

## APPENDIX B: MECHANICAL DRAWINGS

### Deep Cooled Model

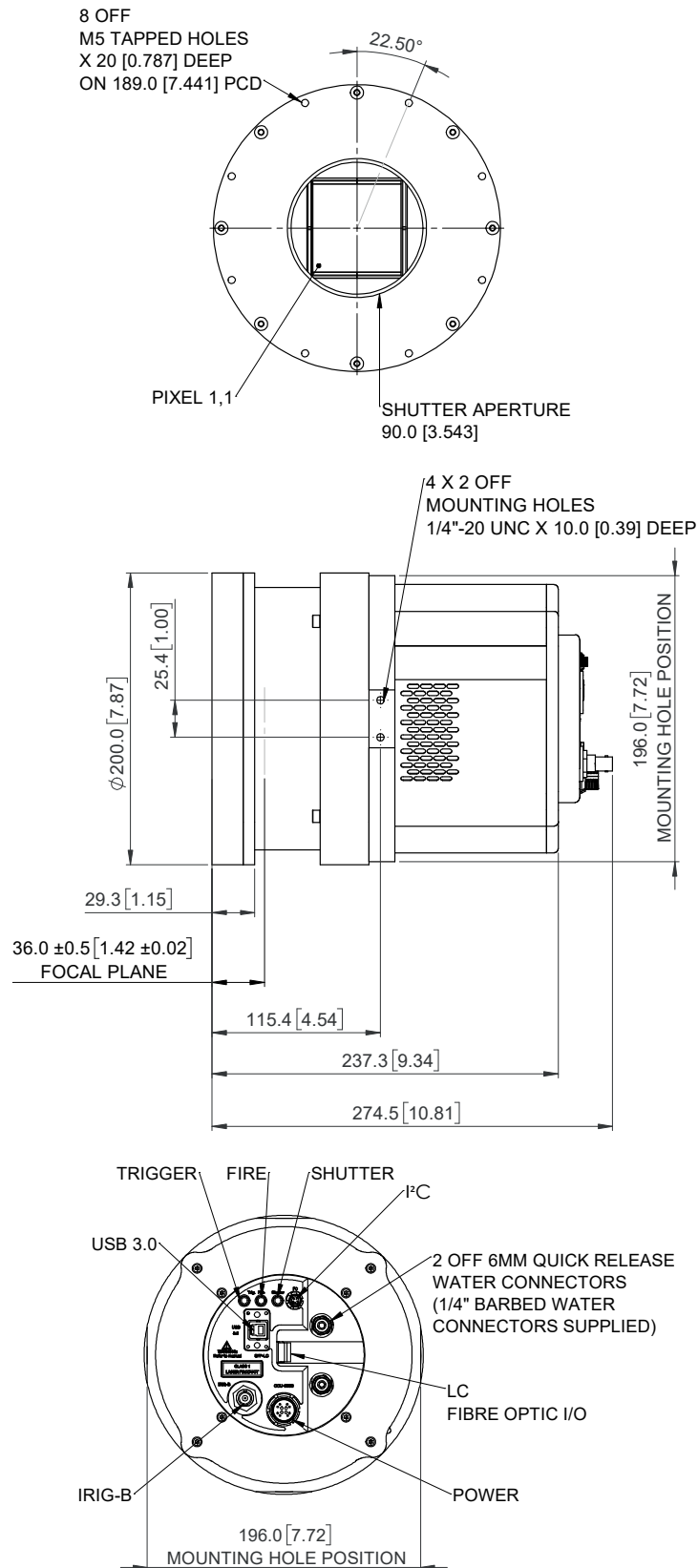

Weight (approx.): 12 Kg [26 lbs 7]

Note: Product drawings of models without shutter can be found at <https://andor.oxinst.com/xl-product-drawings>

Flexi Model

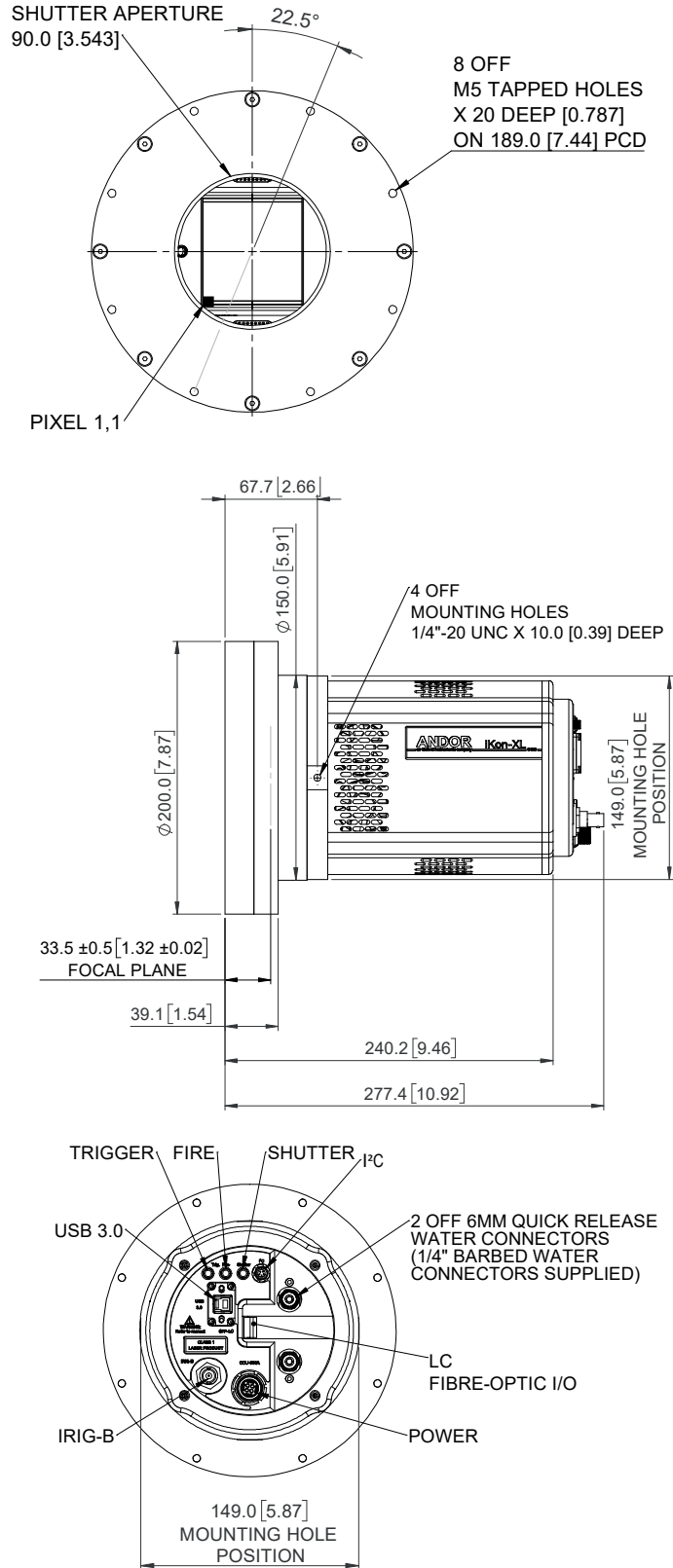

Weight (approx.): 8.25 Kg [18 lbs 3]



Camera Control Unit CCU-500

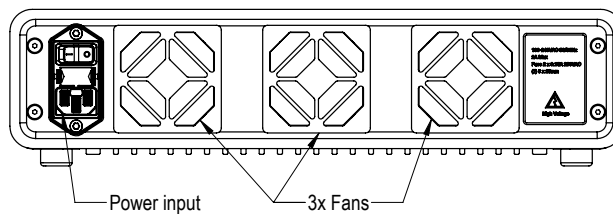
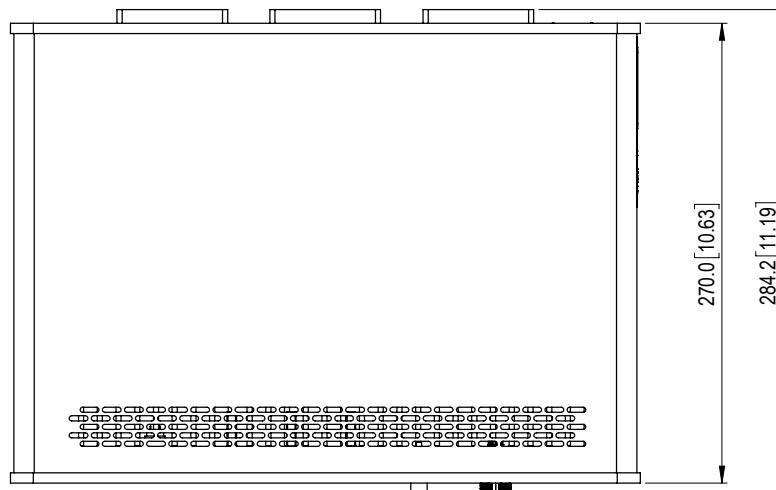
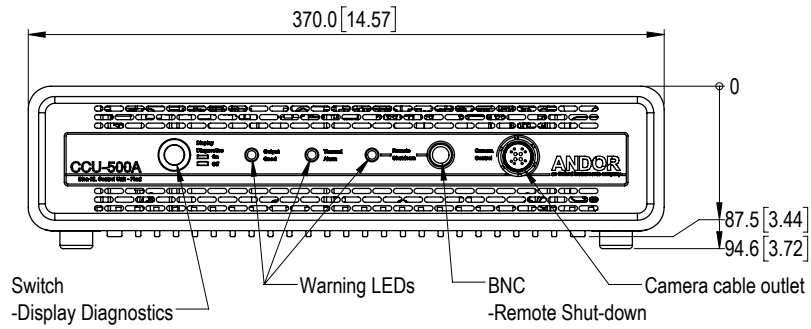

Weight: 6.6 Kg [14 lbs 5] approx.  
(not including cables).

## APPENDIX C: DEWPOINT INFORMATION

To avoid issues with condensation, the coolant temperature must be set above the dewpoint- the temperature at which condensation (dew) will form. In the relatively dry conditions of an air conditioned lab, or a cool dry climate, use of a coolant temperature of 10°C should not cause any problems. As relative humidity or ambient temperature increase however, the dewpoint temperature will also increase so that the minimum coolant temperature that can be used will have to increase accordingly. This will therefore limit the maximum cooling performance that can be achieved.

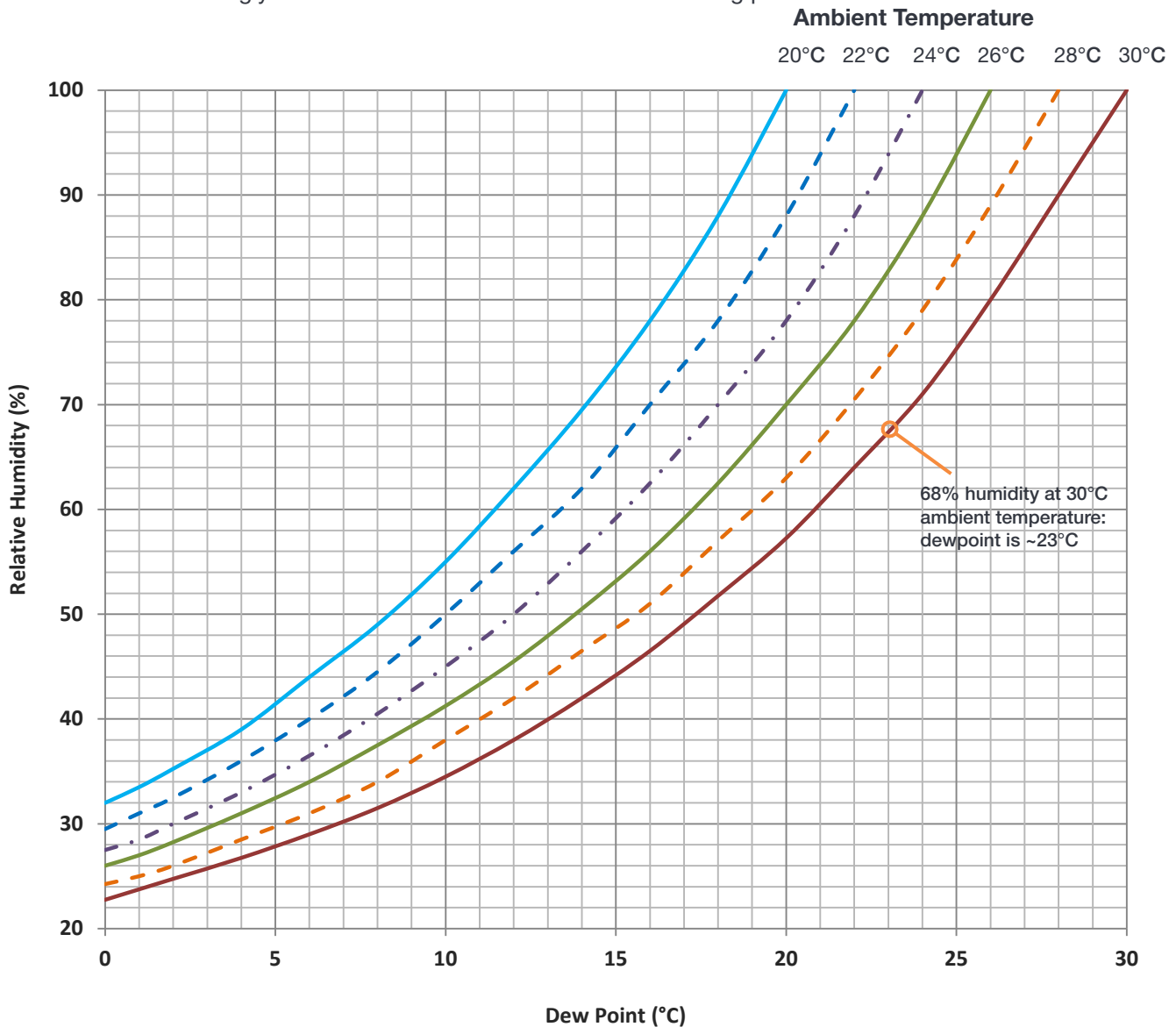

The first signs that condensation is forming will be on the coolant connections entering and exiting the camera. Use of coolant at or below the dewpoint can result in permanent damage to the camera head due to formation of condensation on internal components. It is therefore very important to ensure that coolant temperature is above the dewpoint. Further guidelines are provided in **Section 6.1**. The relationship between Relative Humidity and Dew Point at varying Ambient Temperature is shown above. There is a dewpoint calculator within Solis (as well as a range on-line) that you can enter ambient temperature and relative humidity value to estimate the dewpoint for your conditions.

## APPENDIX D: REFERENCE INFORMATION

### ULTRAVAC™ TECHNOLOGY

**UltraVac** is Andor's proprietary vacuum technology that provides a permanent, hermetically sealed enclosure (without O-rings) for the sensor. This ensures maximum cooling performance, with a reliability proven through years of use in Andor cameras such as the iXon EMCCD, iKon and Newton series- the Mean Time Between Failure (MTBF) value is > 100 years.

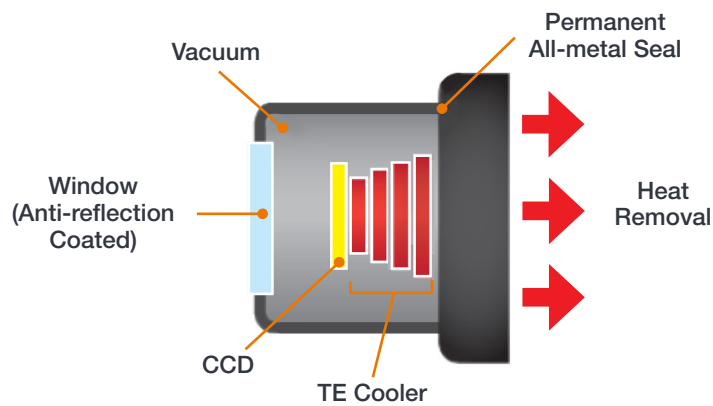

Outgassing is minimized through assembly in a state of the art facility, with a stringent protocol and use of proprietary materials (Outgassing is the release of trapped gasses that would otherwise degrade cooling performance and potentially cause sensor failure). UltraVac also features a single camera window for the best optical performance. For more information about our UltraVac technology, please visit our website and view the technical article on [UltraVac](#).

### COLD SPACE TECHNOLOGY (DEEP-COOLED MODEL)

**Cold Space Technology** is a patent-pending technology from Andor for effective TE cooling of very large area sensors such as is used in the iKon-XL. Using this in combination with UltraVac permanent vacuum technology, it is possible to cool the sensors of the deep cooled iKon-XL model to as low as -100°C (with the aid of liquid cooling). This avoids the use of the Cryo coolers that are known to be cumbersome and unreliable, the requirement for liquid nitrogen LN<sub>2</sub> or periodic vacuum re-pumping.

Minimum Temperatures	Deep Cooled model
@ coolant temperature of 10°C	-100°C
@ coolant temperature of 16°C	-95°C
air cooled	-

### EXTENDED DYNAMIC RANGE TECHNOLOGY

The iKon-XL features Extended Dynamic Range technology- this means it is not necessary to select between low noise (weak signal) or maximum well depth (bright signal) as is typical of normal CCD cameras.

## OPERATION IN 16-BIT AND 18-BIT MODES

To capture the full dynamic range possible using **Extended Dynamic Range Technology**, the iKon-XL facilitates 18-bit digitization (as well as 16-bit) for both 230 and 231 sensor models:

### iKon-XL 230

Speed (readout rate)	100 kHz	1 MHz	2 MHz	4MHz
16-bit mode	•	•	•	•
18-bit mode	•	•	-	-

### iKon-XL 231

High Sensitivity Mode				
Speed (readout rate)	100 kHz	500 kHz	1 MHz	3 MHz
16-bit mode	•	•	•	•
18-bit mode	•	•	•	-
High Capacity Mode				
Speed (readout rate)	100 kHz	500 kHz	1 MHz	3 MHz
16-bit mode	•	•	•	•
18-bit mode	•	•	•	-

• available, - not available

### When should 18-bit mode be used?

18-bit mode provides more flexibility for working with certain high dynamic range images.

16-bit mode facilitates smaller file sizes- therefore if your application does not need 18-bit digitization and storage space is a concern, 16-bit mode should be used.

## HIGH CAPACITY AND HIGH SENSITIVITY MODES

The 231 sensor models enable you to select between a high capacity and a high sensitivity mode of operation.

**High Capacity** mode utilises the full pixel well depth and is most suitable for normal to dynamic conditions containing both low and high signal levels.

**High Sensitivity** mode is most suitable for when you want to determine very small changes in light intensity at very low light levels and using the full capacity of the pixel well depth is not required.

## 1 PORT AND 4 PORT MODES

Standard CCD technology sensors typically feature a single port readout. When using larger sensors with higher resolutions this limits the readout rates that can be achieved. In addition, simply increasing the readout speed of the sensor will tend to increase the readout noise. This places major performance limitations on a larger CCD sensor based on a standard CCD architecture, with the frame rates being too low for many applications. In the 4 (quad) port arrangement of the iKon-XL, the sensor readout architecture is split into four quadrants. When combined with other technical changes, the readout speeds from the sensor can be significantly increased whilst maintaining low noise. The iKon-XL features flexible port readout options and a balanced readout configuration ensuring all readout circuits experience same temperature and operating conditions.

### Sensor Compensation

The iKon-XL features 1 and 4 port mode operation (described in the preceding paragraph). Using 4-port mode facilitates faster framerate performance and keeps noise low. In 4-port mode the sensor is readout using four different amplifiers. These amplifiers will have slightly different sensitivities and offsets, this may lead to small visual differences between the four quadrants comprising the image – if uncorrected.

**Sensor Compensation** Mode has been developed by Andor using proprietary knowledge to correct for any variations in these amplifiers which may lead to visual differences, so that their effects are minimised.

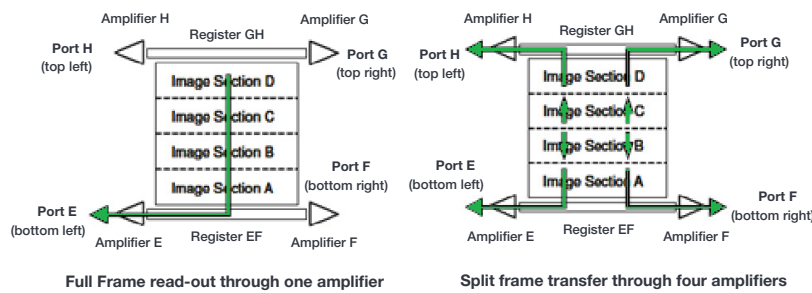

**Note:** Sensor Compensation must be used in conjunction with **Baseline Clamp**.

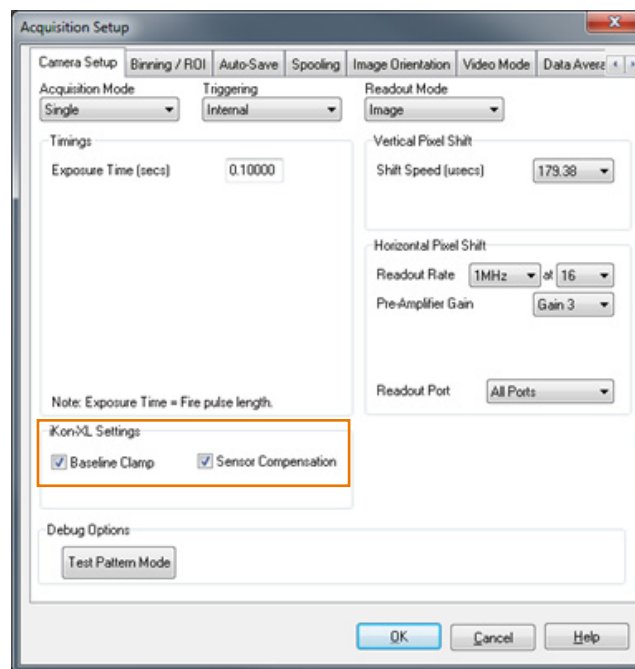

### Baseline Clamp

Traditionally, when acquiring data, small changes – such as caused by heat generation of the driving electronics may cause some drift in the baseline level. This could be an issue during long kinetic series, or dynamic measurements. Baseline Clamp corrects each individual image for any baseline drift by subtracting an average bias signal from each image pixel and then adding a fixed value to ensure that the displayed signal level is always a positive number of counts. As such, the baseline remains at a rock-steady value. Baseline clamp should be enabled by default if Sensor Compensation mode has been selected. Baseline clamp is a key feature of many Andor cameras- further information is available for EMCCD models in a Technical note [Quantitative Stability](#).

### SHUTTER AND TRIGGERING INFORMATION

For shutter and trigger mode operation information please refer to your camera control software e.g. SDK2.



## APPENDIX E: OTHER INFORMATION

---

### TERMS AND CONDITIONS OF SALE AND WARRANTY INFORMATION

The terms and conditions of sale, including warranty conditions, will have been made available during the ordering process. The current version may be viewed at: [www.andor.com/pdfs/literature/Andor\\_Standard\\_Warranty.pdf](http://www.andor.com/pdfs/literature/Andor_Standard_Warranty.pdf)

### WASTE ELECTRONIC AND ELECTRICAL EQUIPMENT REGULATIONS 2006 (WEEE)

The company's statement on the disposal of WEEE can be found in the Terms and Conditions found on the Andor website, [WEEE Policy](#).



## Notes

---

---

---

---

---

---

---

---

---

---