

# Neo 5.5 sCMOS

Version 1.9 rev 28 Jan 2025



## Hardware Guide



	Page
<b>SECTION 1: INTRODUCTION</b> .....	<b>9</b>
1.1 HELP AND TECHNICAL SUPPORT.....	10
1.2 DISCLAIMER.....	11
1.3 TRADEMARKS AND PATENT INFORMATION.....	11
1.4 SPECIFICATIONS.....	12
1.5 COMPONENTS .....	13
1.5.1 OPTIONAL ACCESSORIES .....	13
1.6 POWER SUPPLY UNIT (PSU) .....	14
1.7 CONNECTIONS OVERVIEW .....	15
1.7.1 MULTI I/O TIMING CABLE PIN OUTS.....	15
1.7.2 IMPEDANCE INFORMATION.....	16
1.7.3 OTHER CONNECTIONS.....	17
1.8 COOLING HOSE CONNECTORS .....	18
1.8.1 IMPORTANT CONSIDERATIONS WHEN USING COOLING SYSTEMS .....	18
<b>SECTION 2: FEATURES AND FUNCTIONALITY</b> .....	<b>19</b>
2.1 sCMOS STRUCTURE AND OPERATION.....	19
2.2 TE COOLING .....	20
2.2.1 ULTRAVAC™ .....	20
2.2.2 EFFECT OF TE COOLING ON THE NOISE FLOOR .....	21
2.2.3 EFFECT OF TE COOLING ON HOT PIXEL BLEMISHES .....	22
2.3 ROLLING AND GLOBAL SHUTTER .....	23
2.3.1 ROLLING SHUTTER .....	23
2.3.2 GLOBAL SHUTTER.....	24
2.3.3 SELECTING ROLLING OR GLOBAL SHUTTER.....	25
2.3.3.1 EXAMPLES OF TYPICAL APPLICATIONS FOR GLOBAL SHUTTER MODE .....	25
2.3.4 ROLLING AND GLOBAL SHUTTER MECHANISMS.....	26
2.4 UNDERSTANDING READ NOISE IN sCMOS.....	27
2.4.1 SPURIOUS NOISE FILTER .....	28
2.5 DUAL AMPLIFIER DYNAMIC RANGE .....	29

2.6	SENSOR READOUT OPTIMIZATION .....	31
2.6.1	GAIN CHANNEL CONTROL .....	31
2.6.2	PIXEL READOUT RATE .....	32
2.6.3	ROI SUB-IMAGE.....	32
2.7	TRIGGER MODES .....	33
2.7.1	SOFTWARE ACQUISITION EVENTS AND ENHANCED FIRE TTL SIGNALLING .....	34
2.7.1.1	ENHANCED TTL FIRE SIGNALLING.....	34
2.7.1.2	SOFTWARE EVENTS.....	35
2.7.1.3	EXAMPLE SYSTEM USAGE OF ACQUISITION EVENTS .....	36
2.7.2	ROLLING SHUTTER TRIGGERING MODES.....	37
2.7.2.1	ROLLING SHUTTER INTERNAL TRIGGERING (NON-OVERLAP MODE) .....	39
2.7.2.2	ROLLING SHUTTER INTERNAL TRIGGERING (OVERLAP MODE).....	41
2.7.2.3	ROLLING SHUTTER SOFTWARE TRIGGERING - SHORT EXPOSURES .....	42
2.7.2.4	ROLLING SHUTTER EXTERNAL / SOFTWARE TRIGGERING (NON-OVERLAP MODE).....	43
2.7.2.5	ROLLING SHUTTER EXTERNAL EXPOSURE TRIGGERING (NON-OVERLAP MODE) .....	44
2.7.2.6	ROLLING SHUTTER EXTERNAL EXPOSURE TRIGGERING (OVERLAP MODE) .....	45
2.7.2.7	ROLLING SHUTTER EXTERNAL START TRIGGERING .....	46
2.7.2.8	ROLLING SHUTTER TRIGGERING CONSTRAINTS.....	47
2.7.3	GLOBAL SHUTTER TRIGGERING MODES.....	48
2.7.3.1	GLOBAL SHUTTER INTERNAL TRIGGERING (NON-OVERLAP MODE).....	49
2.7.3.2	GLOBAL SHUTTER INTERNAL TRIGGERING (OVERLAP MODE) .....	51
2.7.3.3	GLOBAL SHUTTER EXTERNAL/SOFTWARE TRIGGERING.....	52
2.7.3.4	GLOBAL SHUTTER EXTERNAL EXPOSURE TRIGGERING (NON-OVERLAP MODE) .....	54
2.7.3.5	GLOBAL SHUTTER EXTERNAL EXPOSURE TRIGGERING (OVERLAP MODE) .....	55
2.7.3.6	GLOBAL SHUTTER EXTERNAL START TRIGGERING.....	56
2.7.3.7	GLOBAL SHUTTER TRIGGERING CONSTRAINTS.....	57
2.8	ACQUISITION MODES.....	58
2.8.1	SINGLE SCAN.....	58
2.8.2	KINETIC SERIES .....	58
2.8.3	ACCUMULATE .....	58
2.8.4	RUN TILL ABORT ACQUISITION .....	58
2.8.5	LIVE MODE.....	59
2.8.6	FAST EXPOSURE SWITCH .....	59
2.8.7	FRAME RATE CONTROL .....	59

<b>SECTION 3: INSTALLATION</b> .....	<b>60</b>
3.1 SAFETY CONSIDERATIONS.....	60
3.2 MOUNTING THE CAMERA.....	60
3.3 MINIMUM COMPUTER REQUIREMENTS .....	60
3.4 INSTALLING SOLIS AND CAMERA LINK DRIVERS .....	60
3.5 CAMERA LINK CONTROLLER CARD INSTALLATION.....	62
3.5.1 INSTALLING THE CAMERA LINK DRIVER.....	63
3.6 CHECKING & SETTING BIOS OPTIONS (FOR PCs NOT SUPPLIED BY ANDOR).....	63
3.7 COOLANT HOSE CONNECTION AND DISCONNECTION.....	64
3.7.1 CONNECTING THE COOLANT HOSES.....	64
3.7.2 DISCONNECTING THE COOLANT HOSES.....	64
<b>SECTION 4: OPERATION</b> .....	<b>65</b>
4.1 CONNECTING THE CAMERA.....	65
4.2 COOLING.....	65
4.2.1 PREVENTION OF CAMERA OVERHEATING .....	65
4.2.1.1 OVERHEAT ALARM RESET .....	65
4.2.2 TE COOLING.....	66
4.3 FAN SETTINGS .....	67
4.4 SOFTWARE SUPPORT.....	68
<b>SECTION 5: MAINTENANCE</b> .....	<b>69</b>
5.1 REGULAR CHECKS .....	69
5.2 ANNUAL ELECTRICAL SAFETY CHECKS .....	69
5.3 FUSE REPLACEMENT .....	69
5.4 COOLING HOSES AND CONNECTIONS.....	69

<b>SECTION 6: TROUBLESHOOTING</b> .....	<b>70</b>
<b>6.1 CAMERA BUZZER DOES NOT SOUND ON START-UP</b> .....	<b>70</b>
<b>6.2 CAMERA IS NOT RECOGNIZED BY PC</b> .....	<b>70</b>
<b>6.3 BUZZER SOUNDS CONTINUOUSLY</b> .....	<b>70</b>
<b>6.4 FAN NOT OPERATING AS EXPECTED</b> .....	<b>70</b>
<b>6.5 CAMERA DOES NOT COOL TO THE REQUIRED TEMPERATURE</b> .....	<b>70</b>
<b>6.6 PREVENTING CONDENSATION</b> .....	<b>71</b>
<b>6.7 FIRE, AUX_OUT AND ARM OUTPUTS NOT FUNCTIONING CORRECTLY</b> .....	<b>71</b>
<b>6.8 EXTERNAL TRIGGER INPUT NOT FUNCTIONING CORRECTLY</b> .....	<b>71</b>

APPENDIX A.1: MECHANICAL DRAWINGS (NEO WITH C-MOUNT) .....	72
APPENDIX A.2: MECHANICAL DRAWINGS (NEO WITH F-MOUNT) .....	73
APPENDIX B: DEW POINT GRAPH .....	74
APPENDIX C.1: WASTE ELECTRONIC AND ELECTRICAL EQUIPMENT REGULATIONS 2006 (WEEE) .....	75
APPENDIX C.2 TERMS AND CONDITIONS OF SALE AND WARRANTY INFORMATION .....	75

## REVISION HISTORY

Version	Released	Description
1.0	05 Oct 2011	Initial Release
1.1	26 Jul 2013	General enhancements to presentation (all Sections). Text revised to improve clarity of information (all Sections). Neo Components revised to show standard supplied components more clearly (Section 1.5) Additional accessories revised to match current options available (Section 1.5.1) Updated timing diagrams and tables for Rolling and Global Shutter Modes (Section 2)
1.2	09 Oct 2013	Updated to show 12-bit data range and gain channels options (Sections 2.6 and 2.7) Updated references to Neo to Neo 5.5.
1.3	15 Oct 2013	Corrected Rolling Shutter External Start Triggering (Non Overlap) (Long Exposures) (Section 2.6.2.7) Amended Global Shutter Internal Triggering (Overlap Mode) table, and added further explanatory text. (Section 2.8.3.2)
1.4	01 Jul 2014	Updated Branding to current format (all Sections) Updated figures 4, 7, 15 and to improve quality (Section 1) Added Blemish Correction Section (2.4.2) Moved Mechanical drawings from Section 1 to Appendix A1 and A2 Added Dew Point Diagram to provide additional guidance (Appendix B) Added support for Windows 8 (Section 3.3)
1.5	17 Apr 2015	Updated for new Neo SL150 model (rear connection panel updated) (Section 1.7) Power supply information updated providing more detail (Section 1.4)
1.6	19 May 2016	Added BIOS options checking and setting for non-Andor supplied PCs (Section 3.6).
1.7	22 May 2017	Timing updated for sCMOS feature alignment. Mechanical Drawings (C and F mount) updated for the FX4 models.
1.8	10 Oct 2024	Added AI translation Disclaimer (Section 1.2)
1.9	28 Jan 2025	Updated "Minimum Computer Requirements" to include Windows 11. (Section 3.3)

## Safety and Warning Information



**WARNING: PLEASE READ THIS SAFETY INFORMATION BEFORE USING YOUR NEO sCMOS CAMERA.**

1. To ensure correct and safe operation of this product, please read this guide before use and keep it in a safe place for future reference.
2. Before using the system, please follow and adhere to all warnings, safety, manual handling and operating instructions located either on the product or in this User Guide.
3. Andor Neo 5.5 sCMOS is a precision scientific instrument containing fragile components. Always handle with care.
4. Ensure that a minimum clearance of approximately 100mm (4") is maintained in front of all ventilation slots and the fan inlet.
5. Use only the power supply cord provided with the system for this unit. Should this not be correct for your geographical area contact your local Andor representative.
6. Only the correctly specified mains supply and fuse must be used.
7. Make sure the electrical cord is located so that it will not be subject to damage.
8. Do not expose the product to open flames.
9. Do not allow objects to fall on the product.
10. Do not expose the product to extreme hot or cold temperatures.
11. Do not expose the product to moisture, wet or spill liquids on the product. Do not store or place liquids on the product. If spillage occurs on the product, switch off power immediately, and wipe off with dry, lint-free cloth. If any ingress has occurred or is suspected, unplug mains cable, do not use, and contact Andor Technical Support.
12. The product contains components that are extremely sensitive to static electricity and radiated electromagnetic fields, and therefore should not be used, or stored, close to EMI/RFI generators, electrostatic field generators, electromagnetic or radioactive devices, or other similar sources of high energy fields.
13. Operation of the system close to intense pulsed sources (e.g. plasma sources, arc welders, radio frequency generators, X-ray instruments, and pulsed discharge optical sources) may compromise performance if shielding of the Neo sCMOS is inadequate.
14. This equipment has not been designed and manufactured for the medical diagnosis of patients
15. Please note that this product is not designed to provide protection from ionising radiation. Any customer using this product in such an application should provide their own protection.
16. If the equipment is used in a manner not specified by Andor, the protection provided by the equipment may be impaired.
17. There are no user-serviceable parts beyond the specified user accessible areas of the product and the enclosure must not be opened. Only authorised service personnel may service this equipment.

## Regulatory Information



The Neo 5.5 sCMOS Camera complies with the requirements of the EU EMC and LV Directives through testing to EN 61326-1 and EN 61010-1.



This product requires a DC power supply (refer to **Section 1.6**)



### SECTION 1: INTRODUCTION

Thank you for choosing the **Neo 5.5 Scientific CMOS (sCMOS) camera**. You are now in possession of a revolutionary new **sCMOS camera**, a breakthrough technology based on the next-generation CMOS image sensor (CIS) design and fabrication techniques.



**FIGURE 1: THE NEO 5.5 sCMOS CAMERA**

The Neo 5.5 sCMOS camera offers:

- Extremely low noise  $1e^-$  read noise
- Rapid frame rates 30 fps full frame sustained (100 fps full frame Burst)
- Wide dynamic range 30,000:1 at 30 fps
- High quantum efficiency Peak QE of 60%
- High resolution 5.5 megapixel
- Large field of view 22 mm

This Hardware Guide contains useful information and advice to ensure you get the optimum performance from your new system. Please refer also to the Software Guide for information on the imaging software to be used with your Neo 5.5 camera. If you have any questions regarding your Neo camera, please feel free to contact Andor directly, or via your local representative or supplier.

The Neo 5.5 camera has been designed for use in research laboratories and other controlled scientific environments.

### 1.1 HELP AND TECHNICAL SUPPORT

If you have any questions regarding the use of this equipment, please contact the representative from whom your system was purchased, or:

#### Europe

**Andor Technology**

7 Millennium Way  
Springvale Business Park  
Belfast  
BT12 7AL  
Northern Ireland  
Tel. +44 (0) 28 9023 7126  
Fax. +44 (0) 28 9031 0792

#### USA

**Andor Technology**

425 Sullivan Avenue  
Suite # 3  
South Windsor  
CT 06074  
USA  
Tel. (860) 290-9211  
Fax. (860) 290-9566

#### Asia-Pacific

**Andor Technology (Japan)**

IS Building  
3-32-42 Higashi-Shinagawa  
Shinagawa-ku,  
Tokyo 140-0002  
Japan  
Tel. +81-3-3518 6488  
Fax. +81-3-3518 6489

#### China

**Andor Technology**

Unit 1, Building A,  
66 Zhufang Rd, Haidian Dist.  
Beijing 100085  
China  
Tel: +86 (0)10 8271 9066  
Fax. +86(0)10 8271 9055

The latest contact details for your local representative can be found on our website via the following link:

<http://www.andor.com/ContactSupport.aspx?type=s>

### 1.2 DISCLAIMER

THE INFORMATION CONTAINED HEREIN IS PROVIDED “AS IS” WITHOUT WARRANTY, CONDITION OR REPRESENTATION OF ANY KIND, EITHER EXPRESS, IMPLIED, STATUTORY OR OTHERWISE, INCLUDING BUT NOT LIMITED TO, ANY WARRANTY OF MERCHANTABILITY, NON-INFRINGEMENT OR FITNESS FOR A PARTICULAR PURPOSE.

IN NO EVENT SHALL ANDOR BE LIABLE FOR ANY LOSS OR DAMAGE, WHETHER DIRECT, INDIRECT, SPECIAL, INCIDENTAL, CONSEQUENTIAL OR OTHERWISE HOWSOEVER CAUSED WHETHER ARISING IN CONTRACT TORT OR OTHERWISE, ARISING OUT OF OR IN CONNECTION WITH THE USE OF THE INFORMATION PROVIDED HEREIN.

PLEASE NOTE, AI TRANSLATIONS OF THIS USER MANUAL MAY RESULT IN INCORRECT INFORMATION. IN THE EVENT OF A CONFLICT WITH A FOREIGN LANGUAGE TRANSLATION, ANDOR’S ENGLISH TRANSLATION WILL PREVAIL.

#### **COPYRIGHT AND PROTECTIVE NOTICES:**

The copyright in this document and the associated drawings are the property of Andor Technology and all rights are reserved. This document and the associated drawings are issued on condition that they are not copied, reprinted or reproduced, nor their contents disclosed.

The publication of information in this documentation does not imply freedom from any patent or proprietary right of Andor Technology or any third party.

### 1.3 TRADEMARKS AND PATENT INFORMATION

Andor, the Andor logo, Neo and Solis are trademarks of Andor Technology. Andor is an Oxford Instruments company. All other marks are property of their owners.

Changes are periodically made to the product and these will be incorporated into new editions of the manual. New releases of the manual are available through MyAndor: <http://my.andor.com/login.aspx>.

### 1.4 SPECIFICATIONS\*

**TABLE 1: SPECIFICATIONS OF THE NEO 5.5 sCMOS CAMERA**

PARAMETER	SPECIFICATION
Power Supply Ratings	100 - 240 VAC (± 5%), 50 - 60 Hz (± 5%)
Power Consumption	Camera only (typ./max): 30W/60W Camera & Ext. PSU (typ./max): 34W/71W
PSU Specifications	Low Voltage Output: 12 V DC. ± 10% Low Voltage Output Ripple: 120 mV max. Steady State Current Output: 7 A min. In-rush Current Capability: 30 A pk (0.1 Ohm source impedance) for 350 µS pulse width (half peak) Output Connector: Redel PAG.M0.2GL.AC52G 2-pin connector
Location to be used	Indoor use only
Altitude	Up to 2000 m
Operating temperature range	0°C to 40°C
Storage temperature	-10°C to +50°C
Operating relative humidity	< 70% non-condensing
Overvoltage category	CAT II. An overvoltage category of CAT II means that the equipment is designed to cope with transient voltages above the rated supply that would be experienced by any product connected to a mains socket in a building.
Pollution degree	Pollution degree 2. Normally only non-conductive pollution occurs. Occasionally, however, a temporary conductivity caused by condensation must be expected.
Ingress protection rating	IP20
Electromagnetic compatibility	This is a Class A product. In a domestic environment this product may cause electromagnetic interference, in which case the user may be required to take adequate measures
Cooling vent clearance	100 mm minimum
Dimensions	132 x 120 x 159.5 mm [5.20 x 8.70 x 6.28 inches]
Weight	3.4 kg [7 lb 8 oz]



\* Specifications are subject to change without notice



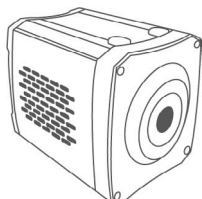

### 1.5 COMPONENTS

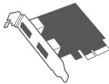
The standard components of the Andor Neo 5.5 system are as follows:

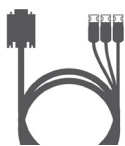
**TABLE 2: STANDARD SUPPLIED COMPONENTS**

Description	Quantity
 <p>Neo 5.5 sCMOS Camera (C or F-mount: as selected at time of ordering)</p>	1

Description	Quantity
 <p>PCIe Camera Link Card</p>	1
 <p>Camera Link cable</p>	1 x 3 m
 <p>Power Supply Unit (PS80) and Country specific Power Cord</p>	1
 <p>Multi I/O Timing cable</p>	1 x 3 m

Description	Quantity
 <p>Anti-static Strap</p>	1
 <p>Individual Performance Sheet</p>	1
 <p>Hardware Guide on CD</p>	1
 <p>Quick Start Guide</p>	1

#### 1.5.1 OPTIONAL ACCESSORIES

There is a range of optional accessories available for your Neo camera including:

- Mounting Adapters ( C-mount to Nikon F-mount, C-mount to Olympus F-mount and C-mount to T-mount)
- Camera Link Cables (5 meter and 10 meter active including power supply)
- Fibre-optic Extenders (30 and 100m fibre-optic extender solutions)
- Re-circulator and Compact Chiller Units for enhanced cooling performance
- Software Development Kit (SDK)
- Solis Image Capture and Analysis Software
- iQ Imaging Software

Please contact Andor or your local representative for further information.

### 1.6 POWER SUPPLY UNIT (PSU)

The Neo 5.5 is powered by an external 12V DC Power Supply Unit (PSU). The connection to the Neo is made via a 2 pin connector. The External Power Supply has an IEC male socket that requires a certified mains lead with an IEC female plug for connection to the mains electrical supply (Refer to Section 1.4 for PSU specifications).

The Neo PSU is for use with Telecommunications, Computer, Industrial Controller and OA Systems and must only be used indoors.

 The Neo camera requires a Direct Current (DC) supply.



FIGURE 2: POWER SUPPLY UNIT

#### NOTES:

1. The electrical mains lead should be certified for use in your country and in applicable countries the plug must be fitted with a 240V 5A fuse
2. If users use any other power supply, they do so at their own risk

### 1.7 CONNECTIONS OVERVIEW

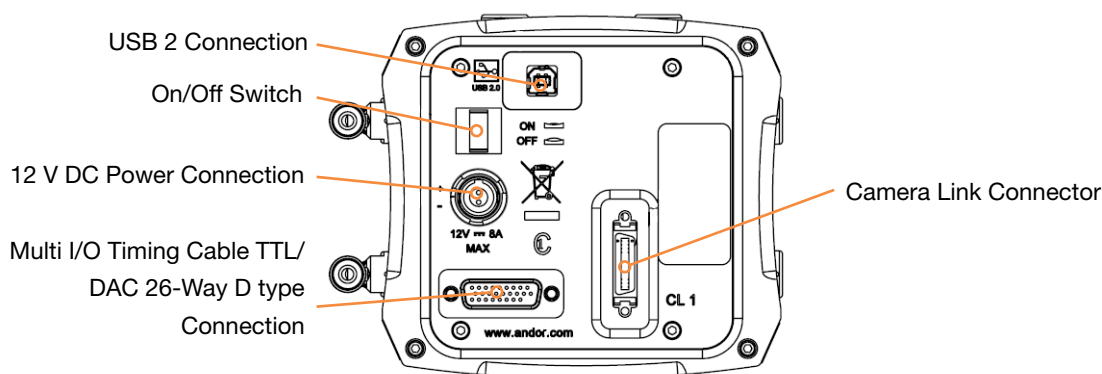

FIGURE 3: CONNECTIONS ON THE BACKPLATE OF THE NEO

#### 1.7.1 MULTI I/O TIMING CABLE PIN OUTS

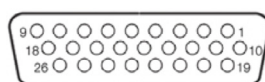

TABLE 3: MULTI I/O TIMING CABLE PINOUTS 26-WAY D TYPE CONNECTOR

1	External Trigger	10	Reserved	19	+5V Output
2	Reserved	11	Reserved	20	GND
3	GND	12	Reserved	21	Reserved
4	Reserved	13	Reserved	22	Reserved
5	Reserved	14	Reserved	23	AUX_OUT_2
6	GND	15	Reserved	24	Arm
7	Reserved	16	Reserved	25	GND
8	Fire	17	Reserved	26	GND
9	AUX_OUT_1	18	GND		

- **External Trigger** is a 5v TTL input. By default it triggers on a rising edge.
- **Fire, Arm, AUX\_OUT\_1** and **AUX\_OUT\_2** outputs are all TTL timing outputs (please also refer to the drawing on the next page for information on impedance matching).
- **+5V Output** is a 5V supply to signal to the user that the camera is powered up. Maximum current which can be drawn from this is 500 mA and this output is fused at 1A.
- **AUX\_OUT\_1** supplies the 'FIRE ALL' output by default. This is the logical AND of the FIRE pulses associated with Row #1 and Row #n (the last row read out in the image frame). Therefore the FIRE ALL pulse represents the time within a frame when all rows on the sensor are simultaneously exposing. **AUX\_OUT\_1** is also configurable as FIRE, FIRE n and FIRE ANY. **The FIRE ANY pulse represents the time within a frame when any row of the image frame is exposing.** Refer to Section 2.6 for the behaviour of these signals and to the SDK3 manual for configuring the AUX\_OUT\_1 output.

**NOTE: This configurable output is only available on cameras with FPGA version numbers  $\geq$  20121002 and Solis versions  $\geq$  4.22.30007.0 (SDK users require version  $\geq$  3.5.30007.0).**

- **AUX\_OUT\_2** output is reserved for future use (Previously labelled Shutter) and is still defaulted permanently to logic level low.

### 1.7.2 IMPEDANCE INFORMATION

TTL and CMOS Compatible

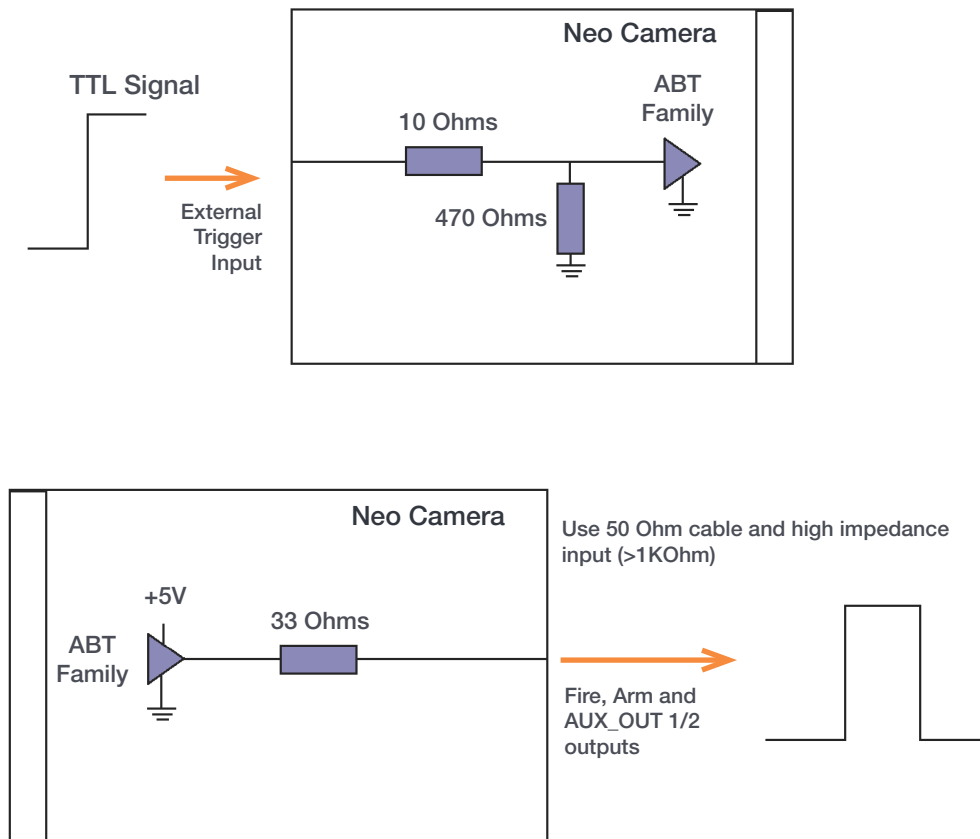

FIGURE 4: NEO CONNECTION IMPEDANCE INFORMATION



### 1.7.3 OTHER CONNECTIONS

- **USB 2.0:** A USB 2.0 compatible cable can be connected between the USB socket and a PC. **NOTE: The USB cable connection is used primarily for Firmware upgrades and should not normally be connected**
- **CL1:** Connection for 3-tap Camera Link cable. (Note: A CL2 connection is present on models manufactured prior to May 2015 with a DC- product code, however it is not used).
- **Power:** 2 pin power connection (Redel PAG.M0.2GL.AC52G connector), outlined below:

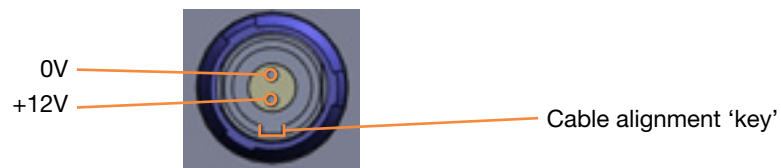

FIGURE 5: NEO 2-PIN POWER SUPPLY CONNECTION

**WARNING:** Use the cable alignment key to ensure correct orientation of power connection. Never forcibly insert the connector otherwise damage to the equipment will occur.

### 1.8 COOLING HOSE CONNECTORS



There are two connectors to allow connection of the Neo to a water cooler or re-circulator to enhance cooling:



**FIGURE 6: COOLING HOSE CONNECTORS**

Please refer to the mechanical drawings in **Appendix A** for details of connector and hose type compatibility and to **Section 3.7** for connection and disconnection information.

#### 1.8.1 IMPORTANT CONSIDERATIONS WHEN USING COOLING SYSTEMS

- Some mains supply water is heavily mineralised, (i.e. “Hard”) which could cause deposits in the water circuit inside the camera. This can reduce the flow-rate and cooling efficiency, therefore it is recommended that de-ionized water (without additives) is used as the coolant to prevent deposits forming.
- The specified cooling performance of the camera can be achieved with coolant flow rate of 2 litres per minute.
- The maximum recommended pressure of coolant circulating through the camera head is 2 bar.
- Always ensure that the temperature of liquid coolant circulated through the camera head is above the dew point of the camera ambient temperature. Use of coolant at or below the dew point will result in permanent damage to the camera head, due to formation of condensation on internal components. A Dew Point graph is shown in **Appendix B**.

## SECTION 2: FEATURES AND FUNCTIONALITY

### 2.1 sCMOS STRUCTURE AND OPERATION

sCMOS technology has been developed specifically to overcome many of the limitations that have marred other scientific detector technologies, resulting in an imaging detector that provides exceptional performance for many applications.

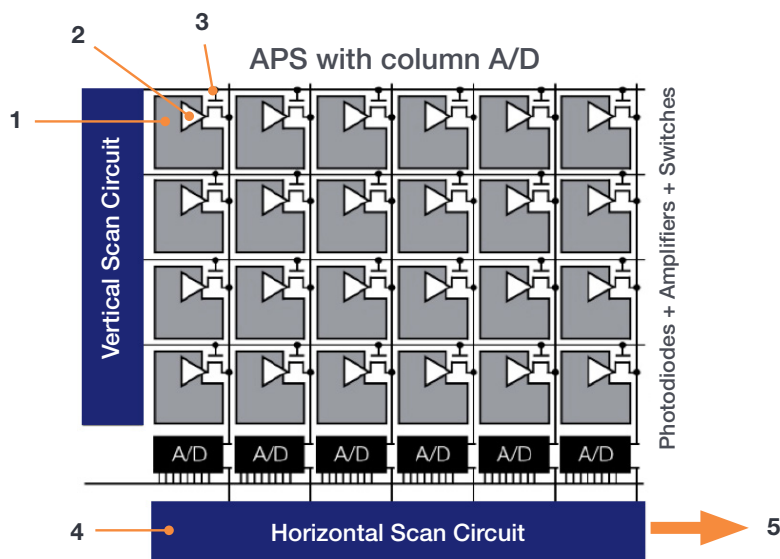

FIGURE 7: sCMOS SENSOR ARCHITECTURE

As illustrated above, the sCMOS sensor is an ‘Active Pixel Sensor’ (APS) whereby each pixel has its own integral amplifier. The sequence of operation is as follows:

1. Light hits sensor and generates charge
2. The photo-generated charge is converted to an analog voltage inside each pixel amplifier
3. Pixel voltage is transferred to the column bus via a row select signal
4. The analog voltage is then converted to a digital signal via columns of A/D (analog to digital) converters
5. The final digitized signals are then read out sequentially at a pixel readout speed of up to 280 MHz (x2 halves)

#### NOTES:

The diagram, above is representative- the light sensitive area is contiguous as the photodiodes for each pixel are buried within the sensor. Each Pixel also has a microlens to maximize sensitivity to light.

For Rolling Shutter mode operation, pixels in each row are exposed and the charge converted to a voltage simultaneously before being digitized then read out sequentially

For Global Shutter mode, each pixel in the sensor begins an exposure simultaneously and then ends that exposure simultaneously

## 2.2 TE COOLING

The read noise of sCMOS technology is extremely low, therefore very careful attention must be given to the contribution of thermal noise, which if left unchecked carries potential to sacrifice the low noise floor advantage. Deep thermoelectric cooling provides the key to maintaining a minimized detection limit through suppression of dark current, and in addition, reducing the occurrence of hot pixel blemishes (see **Section 2.2.3**).

### 2.2.1 ULTRAVAC™

A high performance scientific sensor must be housed in a hermetically sealed vacuum head with minimal out-gassing, otherwise both cooling performance and the sensor QE itself will degrade over time. The Neo sCMOS camera features Andor's proprietary UltraVac™ vacuum technology.

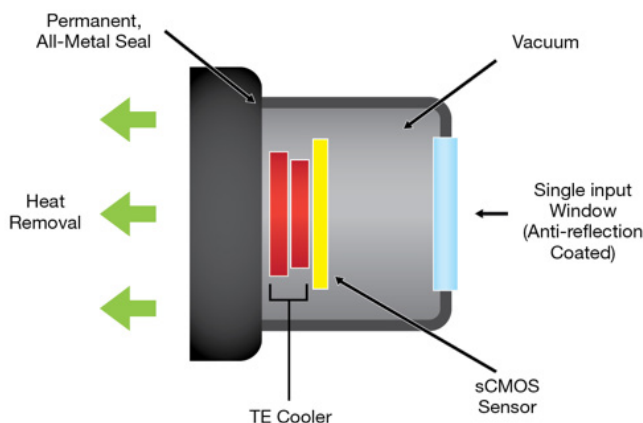

FIGURE 8: ANDOR ULTRAVAC PERMANENT VACUUM HEAD SCHEMATIC

#### Benefits of UltraVac™ Permanent Vacuum Head:

- Sustained vacuum performance over many years operation – process optimized to minimize out-gassing. Peak QE and cooling will not degrade
- Performance improves because the temperature of the chip can be reduced significantly. Better cooling (down to  $-40^{\circ}\text{C}$  in the Neo with an enhanced thermo-electric peltier design) translates into substantially lower dark current and fewer blemishes
- Elimination of condensation and out-gassing means that the system requires only a single entrance window, with double antireflection coating for excellent QE performance
- Prevention of heat transfer from the front window which would otherwise lead to condensation on the outside window

### 2.2.2 EFFECT OF TE COOLING ON THE NOISE FLOOR

The ultra-low value of 1 electron RMS read noise available from sCMOS cameras outperforms even the best CCD to date. Read noise is an important contributor to the noise floor detection limit of a camera, but the noise associated with thermal signal, dark current, should never be overlooked.

For conventional CMOS cameras especially, even modest exposure times can result in a significant increase in dark noise. Furthermore, since sCMOS cameras have a much lower read noise baseline, then the percentage increase in dark current can be proportionally larger.

The Andor Neo 5.5 sCMOS platform is unique as it is the only scientific CMOS camera to offer the level of deep thermoelectric cooling necessary to minimize the detrimental influence of dark noise. **Figure 9** below shows theoretical plots of noise floor versus exposure time, at three different cooling temperatures, +5°C, -30°C and -40°C. The parameters used in determining the overall noise floor are based on a typical read noise 'baseline' of 1 electrons, combined with the measured typical dark current of the sCMOS sensor at each of the temperatures. Combined noise is calculated in quadrature, i.e. using the 'square root of the sum of the squares method'.

Even within the exposure range up to 1 sec (**Figure 9a**), the low noise floor can be notably sacrificed by ~ 2.2 fold at the higher temperature of +5°C. Cooling to either -30°C maintains the 1 electron noise floor over this short exposure range. At an exposure time of 10 sec (**Figure 9b**), the noise floor associated with +5°C is significantly compromised to ~ 6 electrons, i.e. 6 fold greater than the read noise, whereas the noise is maintained under 1.5 electrons with deeper cooling.

For very low light measurements, such as in chemiluminescence, it may be necessary to apply exposure times up to, or greater than 10 minutes. At 600 sec, unless deep cooling is applied, the thermal contribution to the noise floor would become excessively large, shown in **Figure 9(c)** as reaching 49 electrons. Holding the cooling temperature at -40°C would result in the noise floor being held at a more modest 2.3 electrons over this extensive exposure period.

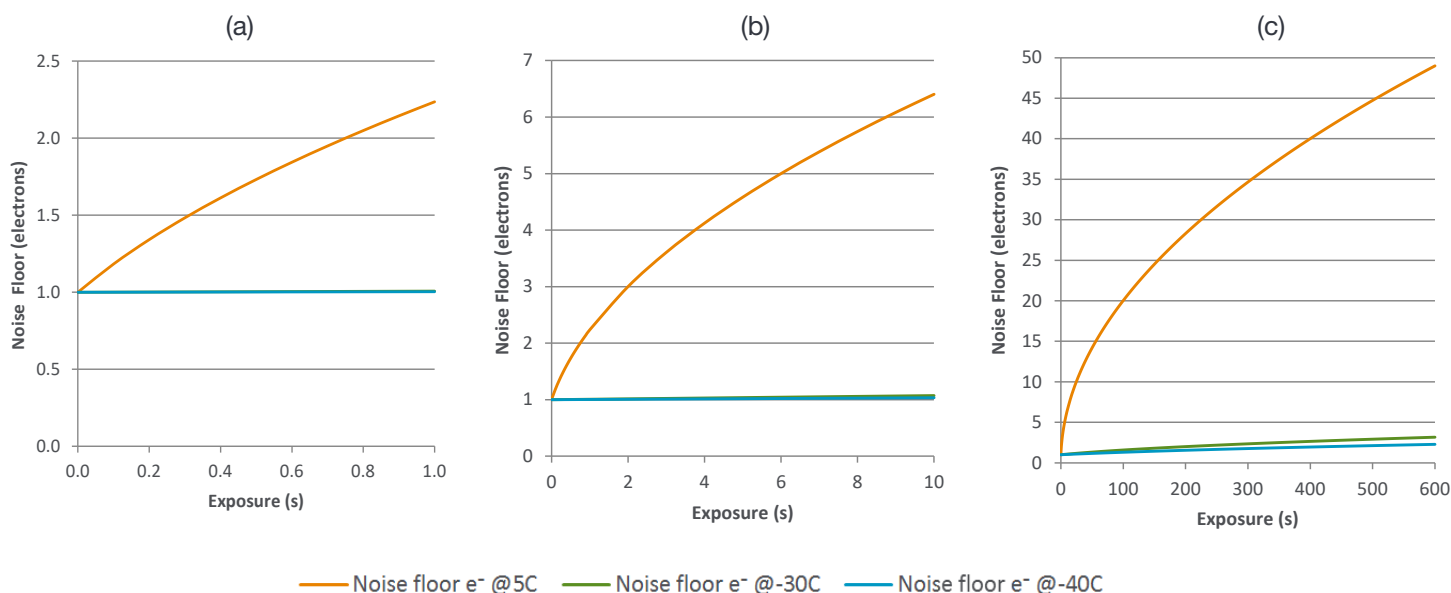

**FIGURE 9: PLOTS OF sCMOS NOISE FLOOR (READ NOISE AND DARK NOISE COMBINED IN QUADRATURE) VERSUS EXPOSURE TIME, AT SENSOR COOLING TEMPERATURES OF +5°C, -30°C AND -40°C. PLOTS ARE SHOWN OVER THREE RANGES OF EXPOSURE TIME; (A) 0.1 - 1 SEC, (B) UP TO 10 SEC AND (C) UP TO 600 SEC.**

### 2.2.3 EFFECT OF TE COOLING ON HOT PIXEL BLEMISHES

CMOS sensors are particularly susceptible to hot pixel blemishes. These are pixels that have significantly higher dark current than the average. Through deep TE cooling of the sensor, it is possible to dramatically minimize the occurrence of such hot pixels within the sensor, meaning that these pixels can still be used for useful quantitative imaging. **Figure 10** below shows a 3D intensity plot of the same 500 x 1000 pixel region of an sCMOS sensor at a number of different cooling temperatures, each recorded with only 1 sec exposure time in Rolling Shutter mode. It is clear that cooling to -30°C and beyond is highly effective in reducing the occurrence of hot pixel spikes, thus offering both an aesthetically cleaner image and a greater proportion of usable pixels.

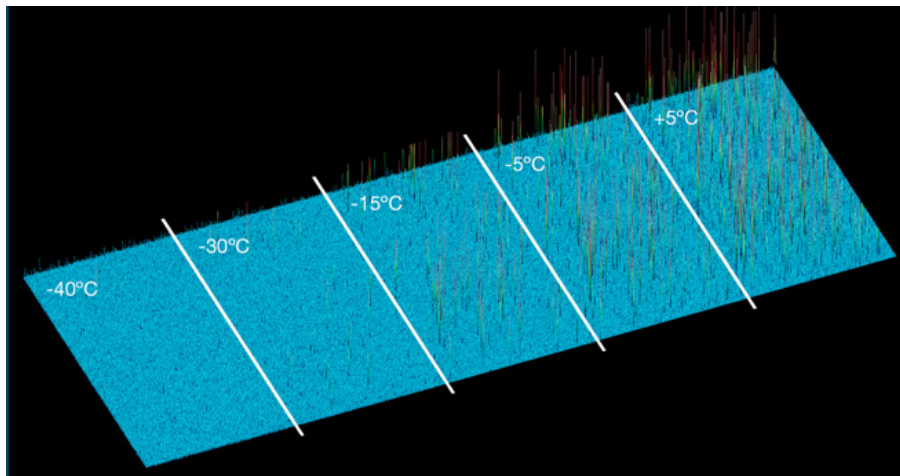

**FIGURE 10: 3D SURFACE INTENSITY PLOTS DERIVED FROM A 500 (W) X 1000 (H) REGION OF INTEREST, 1 SECOND EXPOSURE TIME, AT A SERIES OF COOLING TEMPERATURES, SHOWING THE EFFECT OF SENSOR COOLING IN REDUCING HOT PIXEL BLEMISHES.**

## 2.3 ROLLING AND GLOBAL SHUTTER

The sCMOS sensor used in the Neo 5.5 offers a choice of both Rolling and Global shutter, providing superior application flexibility. Rolling and Global shutter modes describe two distinct sequences through which the image may be read off a CMOS sensor. In rolling shutter, charge is transferred from each row in sequence during readout, whereas in global shutter mode each pixel in the sensor effectively ends the exposure simultaneously. However, lowest noise and fastest frame rates are achieved from rolling shutter mode.

Traditionally, most CMOS sensors offer either one or the other, but very rarely does the user have the choice of both from the same sensor. With the sCMOS technology of the Neo 5.5 it is possible to select between either readout mode from the same sensor, so the most appropriate mode can be selected for the specific application.

### 2.3.1 ROLLING SHUTTER

In Rolling shutter mode, adjacent rows of the array are exposed at slightly different times as the readout ‘waves’ sweep through each half of the sensor. Therefore, each row will start and end its exposure slightly offset in time from its neighbour. At the maximum readout rate of 560 MHz, this offset between adjacent row exposures is 10  $\mu$ s. The rolling shutter readout mechanism is illustrated in **Figure 11**. From the point of view of readout, the sensor is split in half horizontally, and each column is read in parallel from the centre outwards, row after row. At the start of an exposure, the wave sweeps through each half of the sensor, switching each row in turn from a ‘keep clean state’, in which all charge is drained from the pixels, to an ‘exposing state’, in which light induced charge is collected in each pixel. At the end of the exposure, the readout wave again sweeps through the sensor, transferring the charge from each row into the readout node of each pixel. The important point is that each row will have been subject to exactly the same exposure time, but the row at the top (or bottom) of the extremes of the sensor halves would have started and ended its exposure 10 ms (1080 rows x 10  $\mu$ s/row) after the rows at the centre of the sensor.

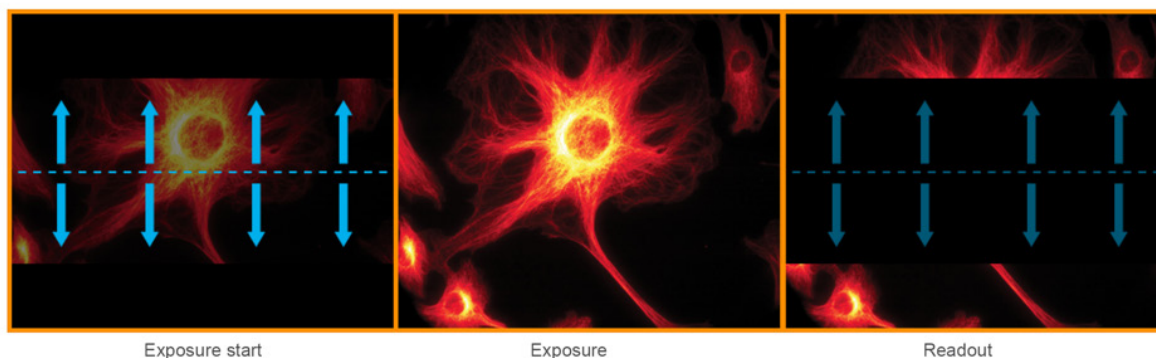

**FIGURE 11: ROLLING SHUTTER EXPOSURE AND READOUT**

Rolling shutter can be operated in a ‘continuous’ mode when capturing a kinetic series of images, whereby after each row has been read out it immediately enters its next exposure. This ensures a 100% duty cycle, meaning that no time is wasted between exposures and, perhaps more importantly, no photons are wasted. At the maximum frame rate for a given readout speed (e.g. 100 fps at 560 MHz) the sensor is continuously reading out, i.e. as soon as the readout fronts reach the top and bottom of the sensor, they immediately return to the centre to readout the next exposure.

The potential downside of rolling shutter, which is spatial distortion resulting from the above described exposure mechanism, has historically been more apparent in devices such as CMOS camcorders, where the entire image field could be moved (for example by the user rapidly panning the camera) at a rate that the image readout could not match; thus, objects could appear at an angle compared to their actual orientation. In reality, despite the time-offset readout pattern, rolling shutter mode is appropriate for the majority of scientific applications, especially where the exposure time is equal to or greater than the sensor readout time, discussed later.

### 2.3.2 GLOBAL SHUTTER

Global shutter mode, which can also be thought of as a ‘snapshot’ exposure mode, means that all pixels of the array are exposed simultaneously. In most respects, global shutter can be thought of as behaving like an Interline CCD sensor. Before the exposure begins, all pixels in the array will be held in a ‘keep clean state’, during which charge is drained into the anti-bloom structure of each pixel. At the start of the exposure each pixel simultaneously begins to collect charge and is allowed to do so for the duration of the exposure time. At the end of exposure each pixel transfers charge simultaneously to its readout node. Importantly, global shutter can be configured to operate in a continuous ‘overlap’ mode (analogous to Interline CCD), whereby an exposure can proceed while the previous exposure is being readout out from the readout nodes of each pixel. In this mode, the sensor has a 100% duty cycle, again resulting in optimal time resolution and photon collection efficiency.

However, the mechanism of global shutter mode demands that a reference readout is performed ‘behind the scenes’, in addition to the actual readout of charge from each pixel. Due to this additional reference readout, global shutter mode carries the trade-off of halving the maximum frame rate that would otherwise have been achieved in rolling shutter mode. In addition, global shutter also increases the RMS read noise by a factor of 1.41 over rolling shutter readout.

**Figure 12** shows a simplified illustration showing sequence of events in global shutter mode:

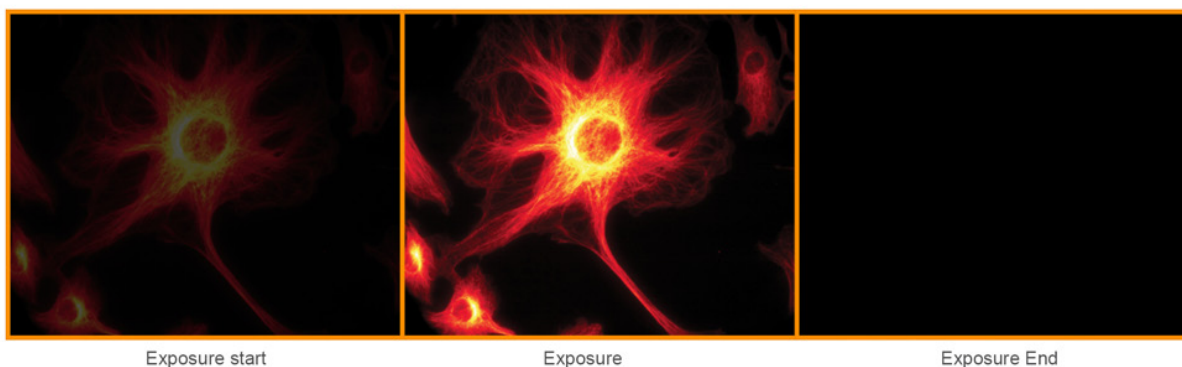

**FIGURE 12: GLOBAL SHUTTER EXPOSURE AND READOUT**



### 2.3.3 SELECTING ROLLING OR GLOBAL SHUTTER

The selection of Rolling Shutter or Global Shutter modes will depend on your specific experimental conditions. A summary of the key parameters for each mode is shown in **Table 4**.

**TABLE 4: A COMPARISON OF ROLLING AND GLOBAL SHUTTER MODES**

PARAMETER	ROLLING SHUTTER MODE	GLOBAL SHUTTER MODE
Frame Rate	Maximum available	Maximum frame rate is halved
Read Noise	Lowest	Increased by 1.41
Spatial Distortion	Dependant on object dynamics and frame rate	None

**Rolling Shutter Mode:** with the enhanced frame rates and lower noise, is likely to suit the majority of scientific applications. As long as the frame rate is such that the camera is temporally oversampling object dynamics within the image area, negligible spatial distortion will be observed. Such oversampling is good imaging practice, since it is undesirable to have an object travel a significant distance during a single exposure.

**Global Shutter Mode:** for some specific applications global shutter will be viewed as a necessity. These are shown in **Section 2.3.3.1**.

Refer also to Andor Technical Note, “Rolling and Global Shutter”.

#### 2.3.3.1 EXAMPLES OF TYPICAL APPLICATIONS FOR GLOBAL SHUTTER MODE

- **Applications that require ‘microsecond’ time gating synced to a pulsed light source:** e.g. Laser Induced Breakdown Spectroscopy (LIBS). Global readout involves a step that simultaneously transfers the signal charge of each pixel into the corresponding readout node for that pixel. This transfer step is 2  $\mu$ s, facilitating fast exposure end, i.e. ‘electronic gating’.
- **‘Double Exposure’ applications:** e.g. Particle Imaging Velocimetry (PIV), which requires that two back-to-back exposures are acquired with minimal time separation between them. The global shutter 2  $\mu$ s transfer time into the readout node defines the minimum time between two consecutive exposures.
- **Applications that require exact time correlation between two (or more) points of an image that are separated vertically within the image:** In rolling shutter it takes 10  $\mu$ s per row for the 2x readout fronts to move across the image from the centre outwards, reading out row at a time. At 560 MHz pixel readout rate, this represents 10 ms to cover the distance from centre to outermost rows. That means an object at the centre of the image will begin and end an exposure ~10 ms before an object located at the very top or bottom (although remember that each object will be subject to the same overall exposure time). If a particular application requires that ‘moving or changing’ objects separated by relatively large distances (vertically) be subject to the same beginning and end of exposure, then global shutter mode is required.
- **Applications where the entire field of view is fast moving (relative to exposure time):** e.g. high speed machine vision inspection, such as PCB inspection.

### 2.3.4 ROLLING AND GLOBAL SHUTTER MECHANISMS

In Rolling Shutter mode, charge transfer happens on a per row basis whilst in global shutter charge transfer happens for the whole sensor or globally. To read out a pixel in Rolling Shutter mode, the following processes occur within the analog circuitry:

1. The read out node is reset
2. The node level (reference level) is measured
3. Charge is transferred from photodiode to node
4. The node level (signal level) is measured
5. The Reference level (Step 2) is subtracted from the Signal level (Step 4) to get the real signal

This process is commonly referred to as CDS (Correlated Double Sampling) and is done in the analog domain before digitization. The reason it is required is due to what is known as reset noise, this arises because every time the node is reset it does not settle at exactly the same level and hence the actual level must be measured (**Step 2** above) and subtracted from the signal level (**Step 4** above) to get the real signal.

**Rolling Shutter Mode:** charge transfer happens on a per row basis; therefore each row follows **Steps 1 – 5** above, until the entire sensor is read out. The disadvantage of this is that the start and end exposure time moves by the row read out time for each subsequent row. So whilst each row of pixels is exposed for exactly the same length of time they do not all start and end at exactly the same time.

**Global Shutter Mode:** the start and end of the exposure do occur at exactly the same time for every pixel (not just for pixels in the same row); therefore **Step 3** has to occur for all the pixels at the same time. Because of this, the reset and reference read occur before this global transfer for every row. Since the same read out circuitry is used for every row there is nowhere to store the measured reference level for every pixel and so a reference frame is actually digitized and read out from the sensor and then the signal is digitized and read out from the sensor. The two are subtracted to get the 'real signal'. Reading two frames to get a real signal frame effectively halves the Cycle Time when compared to Rolling Shutter.

## 2.4 UNDERSTANDING READ NOISE IN sCMOS

sCMOS technology boasts an ultra-low read noise floor that significantly exceeds that of even the best CCDs, and at several orders of magnitude faster pixel readout speeds. For those more accustomed to dealing with CCDs, it is useful to gain an understanding of the nature of read noise distribution in CMOS imaging sensors.

CCD architecture is such that the charge from each pixel is transferred through a common readout structure, at least in single output port CCDs, where charge is converted to voltage and amplified prior to digitization in the Analog to Digital Converter (ADC) of the camera. This results in each pixel being subject to the same readout noise. However, CMOS technology differs in that each individual pixel possesses its own readout structure for converting charge to voltage. In the sCMOS sensor, each column possesses dual amplifiers and ADCs at both top and bottom (facilitating the split sensor readout). During readout, voltage information from each pixel is fed directly to the appropriate amplifier/ADC, a row of pixels at a time (see Technical Note on Rolling and Global Shutter modes).

As a consequence of each pixel having its own individual readout structure, the overall readout noise in CMOS sensors is described as a distribution, as shown in **Figure 13**, which is a representative noise histogram from a Neo sCMOS camera at the fastest readout speed of 560 MHz (or 280 MHz x 2 halves). It is standard to describe noise in CMOS technology by citing the median value of the distribution. In the data presented, the median value is 1.1 electron RMS. This means that 50% of pixels have a noise less than 1.1 electrons, and 50% have noise greater than 1.1 electrons. While there will be a small percentage of pixels with noise greater than 2 or 3 electrons, observable as the low level tail towards the higher noise side of the histogram, it must be remembered that a CCD Interline camera reading out at 20 MHz would have *all* pixels reading out with read noise typically ranging between 6 and 10 electrons RMS (depending on camera design).

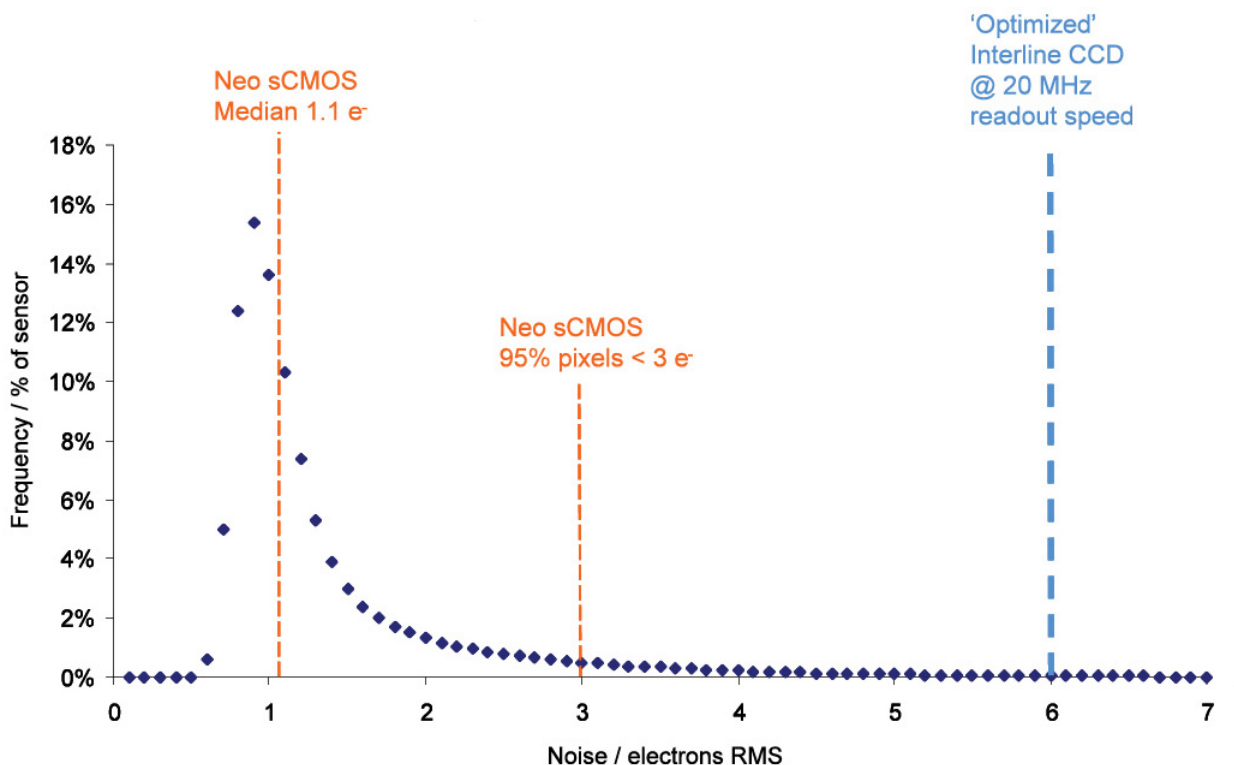

**FIGURE 13: REPRESENTATIVE HISTOGRAM SHOWING READ NOISE DISTRIBUTION AT FASTEST READOUT SPEED OF 280 MHz (x2). THE MEDIAN VALUE OF 1.1E<sup>-</sup> MEANS 50% PIXELS HAVE LESS THAN 1.1 E<sup>-</sup> AND 50% HAVE GREATER THAN 1.1 E<sup>-</sup>. THE LINE AT 6 E<sup>-</sup> REPRESENTS A TYPICAL READ NOISE VALUE FROM A WELL OPTIMIZED INTERLINE CCD – ALL PIXELS IN A CCD ESSENTIALLY SHARE THE SAME NOISE VALUE**

### 2.4.1 SPURIOUS NOISE FILTER

The Spurious Noise filter corrects for pixels that would otherwise appear as spurious ‘salt and pepper’ noise spikes in the image. The appearance of such noisy pixels is analogous to the situation of Clock Induced Charge (CIC) noise spikes in EMCCD cameras, in that the overall noise of the sensor has been reduced to such a low level, that the remaining small percentage of spurious, high noise pixels can become an aesthetic issue. The filter actively identifies such high noise pixels and replaces them with the mean value of the neighbouring pixels.

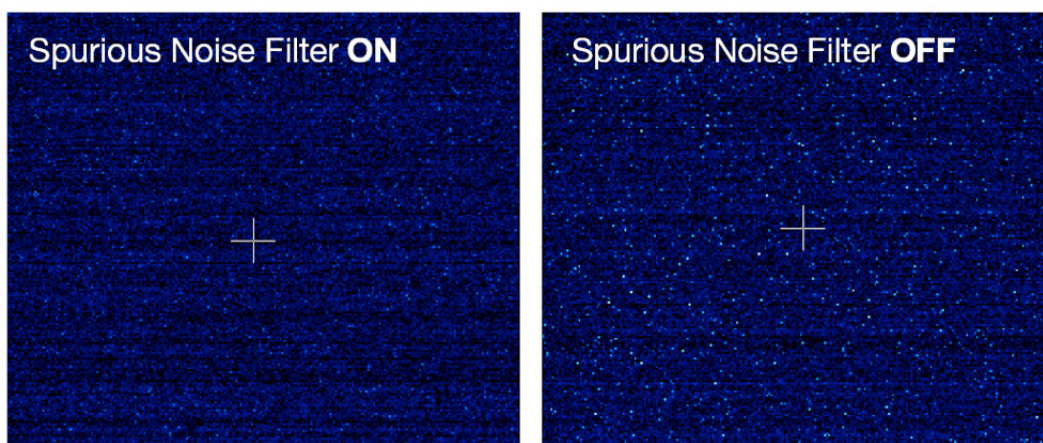

FIGURE 14: DEMONSTRATION OF SPURIOUS NOISE FILTER ON A DARK IMAGE, 20 MS EXPOSURE TIME, 200 MHZ (x2 HALVES) READOUT SPEED

### 2.4.2 BLEMISH CORRECTION

This **Blemish Correction** filter identifies and compensates for three types of blemishes during the FPGA processing step:

1. Hot Pixel's
2. Noisy Pixel's
3. Unresponsive Pixel's

sCMOS sensors are particularly susceptible to hot pixel blemishes. These are spurious noise pixels that have significantly higher darkcurrent than the average. Through deep TE cooling of the sensor (e.g.  $-30^{\circ}\text{C}$  in the Neo), it is possible to dramatically minimize the occurrence of such hot pixels within the sensor, meaning that these pixels can still be used for useful quantitative imaging. However, if deep cooling cannot be achieved it is necessary to use interpolative filters to minimize the hot pixel blemishes. These filters work by taking the mean of the surrounding 8 pixel values and replacing this hot pixel blemish with this mean value. Such interpolation over pixel blemishes can be detrimental in some applications that depend on total quantitative integrity over a limited set of pixels, for example in localization based super-resolution microscopy (such as PALM and STORM techniques) and astronomy. In these applications it is essential for the user to be able to switch off interpolative corrections.

Furthermore, having access to the location of these blemishes allows an accurate map of ‘good’ pixels to be determined by the user. A new service allows the end user to request a ‘hot pixel map’ of their sCMOS sensor from Andor. This map will be generated based on the experimental conditions outlined by the end user.

In Andor SDK3 (version 3.7.30004 onwards) and Solis (version 4.24.30004 onwards) blemish correction can be switched on and off by the user. Refer to the SDK and Solis user guide and help information for instructions.

### 2.5 DUAL AMPLIFIER DYNAMIC RANGE

The Dual Amplifier architecture of the sCMOS sensor in Neo 5.5 eliminates the need to choose between low noise or high capacity, as the signal can be sampled simultaneously by both high gain and low gain amplifiers. The lowest noise of the sensor can be harnessed alongside the maximum well depth to provide the widest possible dynamic range. Traditionally, scientific sensors including CCD, EMCCD, ICCD and CMOS, demand that the user must select ‘upfront’ between high or low amplifier gain (i.e. sensitivity) settings, depending on whether they want to optimize for low noise or maximum well depth. Since the true dynamic range of a sensor is determined by the ratio of well depth divided by the noise floor detection limit, then choosing either high or low gain settings will restrict dynamic range by limiting the effective well depth or noise floor, respectively.

For example, consider a large pixel CCD, with 16-bit Analog to Digital Converter (ADC), offering a full well depth of  $150,000 e^-$  and lowest read noise floor of  $3 e^-$ . The gain sensitivity required to give lowest noise is  $1 e^-/ADU$  (or ‘count’) and the gain sensitivity required to harness the full well depth is  $2.3 e^-/ADU$ , but with a higher read noise of  $5 e^-$ . Therefore, it does not automatically follow that the available dynamic range of this sensor is given by  $150,000/3 = 50,000:1$ . This is because the high sensitivity gain of  $1 e^-/ADU$  that is used to reach  $3 e^-$  noise means that the 16-bit ADC will top out at  $65,536 e^-$ , well short of the  $150,000 e^-$  available from the pixel. Therefore, the actual dynamic range available in ‘low noise mode’ is  $65,536/3 = 21,843:1$ . Conversely, the lower sensitivity gain setting means that the ADC will top out at  $\sim 150,000 e^-$ , but the higher read noise of  $5 e^-$  will still limit the dynamic range to  $150,000/5 = 30,000:1$  in this ‘high well depth mode’. The sCMOS sensor offers a unique dual amplifier architecture, meaning that signal from each pixel can be sampled simultaneously by both high and low gain amplifiers. The sensor also features a split readout scheme in which the top and bottom halves of the sensor are read out independently. Each column within each half of the sensor is equipped with dual column level amplifiers and dual analog-to-digital converters, represented by the block diagram below:

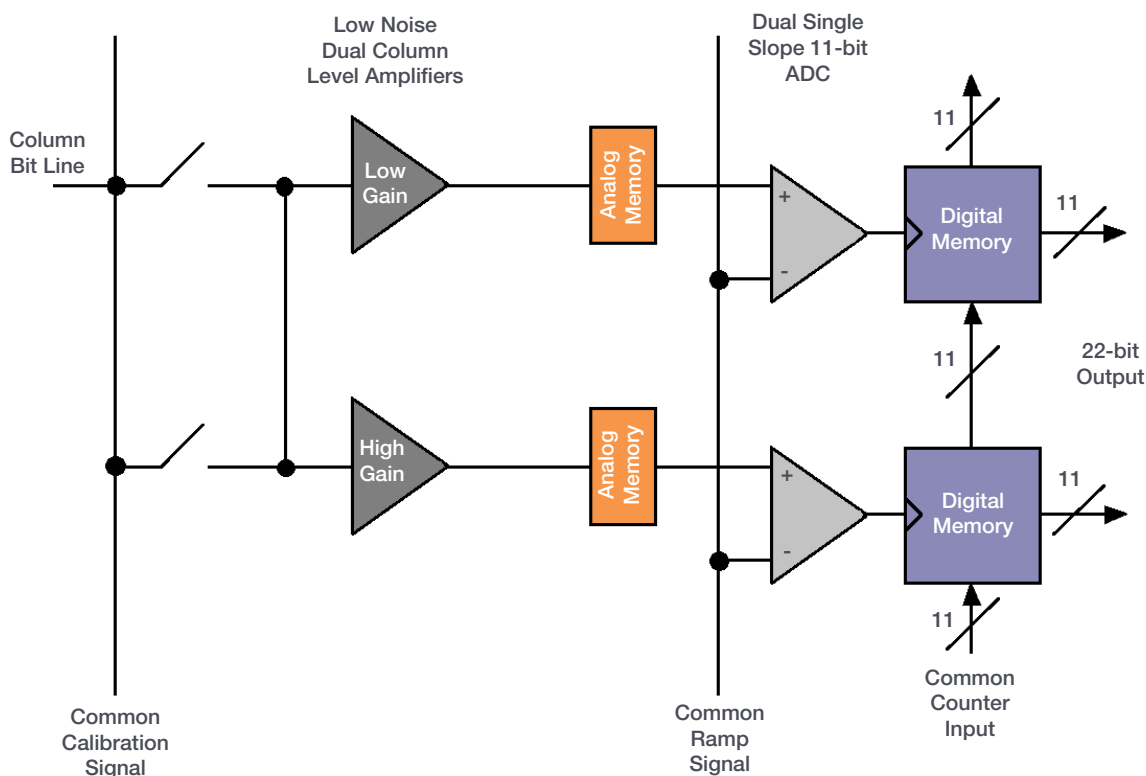

FIGURE 15: AMPLIFIERS AND ADC OF THE NEO 5.5 sCMOS SENSOR

The dual column level amplifier/ADC pairs have independent gain settings, and the final image (see figure 16) is reconstructed by combining pixel readings from both the high gain and low gain readout channels to achieve a wide intra-scene dynamic range, especially for the relatively small 6.5  $\mu\text{m}$  pixel pitch.

The method of combining signals from two 11-bit ADCs can be divided into four basic steps.

1. At the end of the analog chain the “Signal” voltage is applied to two independent amplifiers: the high gain amplifier and the low gain amplifier. This results in two separate digital data streams from the sensor
2. The camera selects which data stream to use on a pixel per pixel, frame by frame basis using a threshold method
3. The data is then compensated for DC offset and gain. Again, this is done on a pixel by pixel basis using the compensation data associated with the data stream. The gain corrects for pixel to pixel relative sensitivity, pixel node amplifier and the high and low amplifier relative gains
4. The pixels are then combined into a single 16-bit image for transfer to the PC

The user maintains the choice of opting to stay with 12-bit single gain channel data if dynamic range is not critical, resulting in smaller file sizes. This in turn offers faster frame rates when continuously spooling through the Camera Link interface and writing to hard disk.

**NOTE: The transition time required for splicing the two gain channels together has been optimized.**

**TABLE 5: TYPICAL PERFORMANCE OF SUPPORTED GAIN SETTINGS OF sCMOS CIS 2521 SENSOR (APRIL 2017 ONWARDS)**

AMPLIFIER GAIN (CURRENT ANDOR SDK / SOLIS DESCRIPTION)	MODE	SENSITIVITY $e^-$ / ADU (TYPICAL)	DATA RANGE	EFFECTIVE PIXEL SATURATION LIMIT / $e^-$	SPOOLING FILE SIZE (PER FRAME)
12-bit (high well capacity)	GS/RS	7.5	12-bit	30,000	8.0 MB
12-bit (low noise)	GS	0.42	12-bit	1,700	8.0 MB
12-bit (low noise)	RS	0.28	12-bit	1,100	8.0 MB
16-bit (low noise and high well capacity)	GS/RS	0.45	16-bit	30,000	10.5 MB

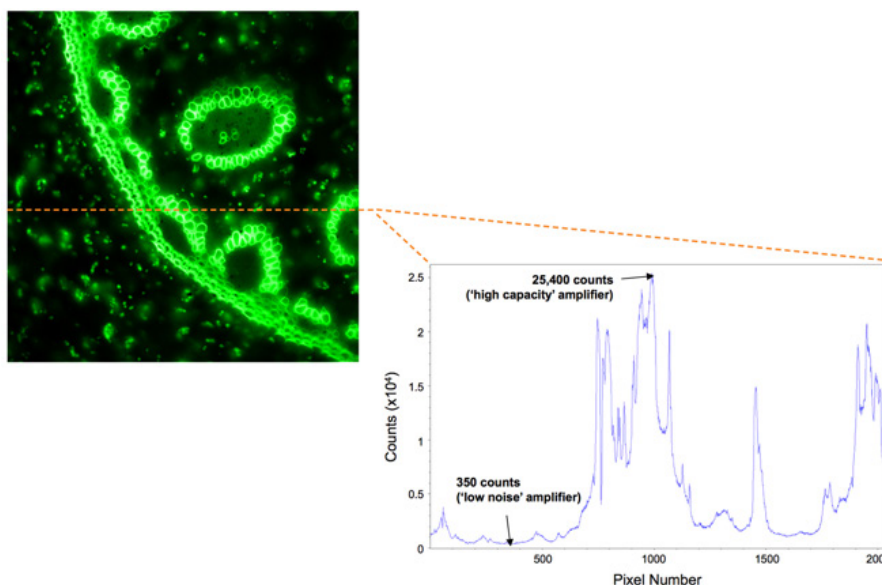

**FIGURE 16: HIGH CONTRAST IMAGE OF FIXED LABELLED CELL. INTENSITY LINE PROFILE THROUGH SINGLE ROW DEMONSTRATES PIXEL REGIONS THAT WERE SAMPLED BY HIGH GAIN (LOW NOISE) AND LOW GAIN (HIGH CAPACITY) AMPLIFIERS.**

## 2.6 SENSOR READOUT OPTIMIZATION

To allow the camera to be optimized for the widest range of applications it is important to have flexibility in the readout options available, some of these include:

- Cooling Options (please see **Section 2.2** for further information)
- Control of Pre Amp Gain
- Adjustment of Pixel Readout Rate
- Selection of Electronic Shutter Mode (rolling or global)
- Selection of ROI sub-image settings

### 2.6.1 GAIN CHANNEL CONTROL

The Neo 5.5 offers the user a choice of two 12-bit gain channels (i.e. high or low gain) or a combined '16-bit' setting. The user can choose to stay with 12-bit single gain channel data if dynamic range is not critical, resulting in smaller file sizes. This in turn offers faster frame rates when continuously spooling through the Camera Link interface and writing to hard disk. The 16-bit dual gain channel should be chosen if dynamic range is more important than faster frame rates. Please refer to **Section 2.5** for more detailed explanation of the dual amplifier dynamic range operation:

**TABLE 6: GAIN SETTINGS FOR ROLLING SHUTTER**

GAIN CHANNEL	SENSITIVITY $e^-/ADU$ (TYPICAL)	DATA RANGE	EFFECTIVE PIXEL SATURATION LIMIT / $e^-$ (TYPICAL)	SPOOLING FILE SIZE (MB)
High Well Capacity	7.5	12-bit	30,000	8.0
Low Noise	0.28	12-bit	1,100	8.0
High Well Capacity and Low Noise	0.45	16-bit	30,000	10.5

**TABLE 7: GAIN SETTINGS FOR GLOBAL SHUTTER**

GAIN CHANNEL	SENSITIVITY $e^-/ADU$ (TYPICAL)	DATA RANGE	EFFECTIVE PIXEL SATURATION LIMIT / $e^-$ (TYPICAL)	SPOOLING FILE SIZE (MB)
High Well Capacity	7.5	12-bit	30,000	8.0
Low Noise	0.42	12-bit	1,700	8.0
High Well Capacity and Low Noise	0.45	16-bit	30,000	10.5

### 2.6.2 PIXEL READOUT RATE

The **Pixel Readout Rate** defines the rate at which pixels are read from the sensor. The faster the readout rate the higher the frame rate that can be achieved. The ability to change the pixel readout speed is important to achieve the maximum flexibility of camera operation.

Slower readout typically allows lower read noise but at the expense of slower frame rates. The following readout rates are available on the Neo 5.5 (the table below shows the typical read noise at each readout rate):

- 100 MHz x 2 halves = 200 MHz readout rate
- 280 MHz x 2 halves = 560 MHz readout rate

**TABLE 8: READ NOISE AT 200 AND 560 MHz FOR ROLLING AND GLOBAL SHUTTER MODES**

RATE	READ NOISE (e <sup>-</sup> ) - ROLLING SHUTTER (TYPICAL)	READ NOISE (e <sup>-</sup> ) - GLOBAL SHUTTER (TYPICAL)
200 MHz	1.0	2.3
560 MHz	1.3	2.5

Please refer to **Section 2.6** for more information on read noise and the camera performance sheet for read noise values at the various readout speeds.

### 2.6.3 ROI SUB-IMAGE

**ROI Sub Image** allows for readout of a particular sub-area of the sensor. When a sub image has been defined, only data from the selected rows will be digitized.

Selecting a sub image increases the frame readout rate and reduces image storage requirements. Examples of sub-image selection and spooling rates are shown in **Table 9** below:

**TABLE 9: EXAMPLE OF ROI AND FRAME RATES (CENTRED ON SENSOR MID LINE)**

ARRAY SIZE	CAMERA LINK BASE		BURST TO 4 GB INTERNAL MEMORY	
	ROLLING SHUTTER	GLOBAL SHUTTER	ROLLING SHUTTER	GLOBAL SHUTTER
2560 x 2160 (full frame)	30	30	100	49
2048 x 2048	39	39	105	52
1920 x 1080	79	79	199	97
1392 x 1040	115	101	206	101
512 x 512	374	201	419	201
128 x 128	1,470	716	1,639	716

**NOTE: The rates shown above are the maximum achievable, actual readout rates will vary depending on performance of PC.**

It should also be noted that while ROIs can also be set up for any area of the sensor, those which are centred on the sensor mid line will result in the maximum frame rates.



## 2.7 TRIGGER MODES

The Neo 5.5 camera has the following triggering modes:

- **Internal Trigger:** the camera determines the exact time when an exposure happens based on the acquisition settings entered by the user. This is the most basic trigger mode and requires no external intervention.
- **External Trigger:** the camera and software are in a high state of readiness to accept a trigger from an external source. Refer to **Table 14** for the minimum pulse width required to guarantee a trigger. The external trigger is fed via the External Trigger input on the I/O Connector on the camera head.
- **Software Trigger:** works in the a similar manner to External Trigger mode whereby the camera and software are in a high state of readiness and can react extremely quickly to a trigger event issued via software. This mode is particularly useful when the user needs to control other equipment between each exposure and does not know in advance how long such control will take or if the time taken changes randomly.
- **External Start:** a mode where the camera will wait for one external trigger event to occur after the acquisition sequence has been started. Once this external trigger event is detected, the camera will start the Internal Trigger read out process and will progress as if the camera was in internal trigger mode.
- **External Exposure Trigger:** a mode of operation where the exposure time and cycle time are controlled by the external trigger input.

The TTL outputs may be used to synchronize the camera operation with external events or equipment.

The individual outputs are described in **Sections 2.7.2** and **2.7.3**.

The AUX\_OUT\_1 output can be configured via software (Solis or SDK) to provide one of the following outputs: FIRE, FIRE n, FIRE ALL or FIRE ANY.

The default state provides FIRE ALL on this output.

The polarity of the TTL inputs and outputs can also be inverted (individually) via either Solis or SDK.

**NOTE: Row 1 is the first row read out in the image frame. Row n is the last row read out in the image frame**

**NOTE: The Trigger diagrams in the following sections are for outlining the events and timing of outputs in the various trigger modes and are not to scale.**

### 2.7.1 SOFTWARE ACQUISITION EVENTS AND ENHANCED FIRE TTL SIGNALLING

The Neo 5.5 camera now includes both software acquisition events (for example fast software notification of start and end of exposure) and enhanced TTL Fire signalling for both Global and Rolling Shutter modes to facilitate the use of the camera in systems where camera synchronisation is required with other devices such as light source controllers or physical stage movements. **Figure 17** shows an example of some of the SW acquisition events and the enhanced Fire TTL signals. Software Acquisition Events are only accessible via SDK - these are not available in Solis, iQ or other software.

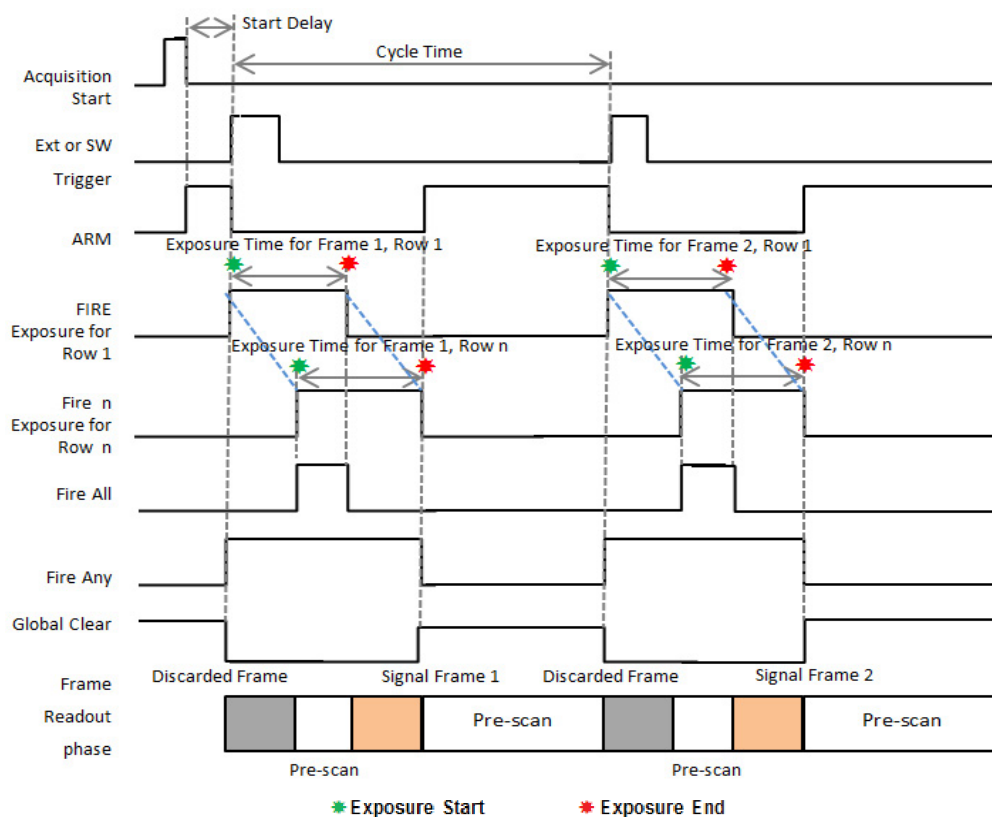

**FIGURE 17: SW ACQUISITION EVENTS AND FIRE TTL SIGNALS - ROLLING SHUTTER EXTERNAL/SOFTWARE TRIGGER TRIGGERING (NON-OVERLAP MODE) (LONG EXPOSURES)**

#### 2.7.1.1 ENHANCED TTL FIRE SIGNALLING

In addition to the dedicated Fire TTL, **Table 10** below shows the behaviour of the various TTL Fire signals available on the AUX\_OUT\_1 output (Refer to timing diagrams in the Triggering section). Note that the behaviour in short exposure and overlap modes sometimes results in no activity on some Fire signals.

**TABLE 10: BEHAVIOUR OF TTL FIRE SIGNALS AVAILABLE ON THE AUX\_OUT\_1 OUTPUT**

HARDWARE EVENT NAME	BEHAVIOUR IN RS MODE	BEHAVIOUR IN GS MODE
Fire	Indicates the time period when row 1 is exposing.	Indicates the time period when all rows are exposing.
Fire n	Indicates the time period when row n is exposing.	As per Fire signal
Fire All (default setting)	Indicates the time period when all rows in a particular frame are being exposed at the same time.	As per Fire signal
Fire Any	Indicates the time period when any row in a particular frame is being exposed.	As per Fire signal

**NOTE: All Fire TTL signals are active high**

On Neo 5.5 cameras with FPGA versions  $\geq 121002$  the above TTL Fire output behaviour is multiplexed onto AUX\_OUT\_1 on the ACZ-02991 Multi I/O cable and is user configurable via either Solis or SDK.

All systems offer Fire signal on dedicated output pins from the 26-way I/O connector.

### 2.7.1.2 SOFTWARE EVENTS

The available software events and their behaviour are shown in **Table 11**. These events can be individually enabled/disabled. Refer to timing diagrams in the Triggering section to see the occurrences of these events. Refer to SDK3 manual for further information on configuration of software events. Users can register for any or all of the events below, although it is recommended that only events which are needed are enabled to minimise load on the PC.

**NOTE: Software Acquisition Events are only accessible via SDK- these are not available in Solis, iQ or other software but may be used internally.**

**NOTE: SW Trigger is not an actual TTL pulse, simply an indication of the time from the SDK function being called until the camera responds to the event. Also the ExposureEndEvent of 1.5ms is approximately the time from the end of the exposure until the software event is signalled to the user code. The actual length of time will depend on various parameters outside the control of the SDK or user software such as background tasks in the OS.**

**NOTE: Software Acquisition Events (SDK only) are available on Neo 5.5 cameras with FPGA versions  $\geq 121002$  and SDK version  $\geq 3.5.30007.0$ .**

**TABLE 11: SOFTWARE EVENTS AND BEHAVIOUR IN ROLLING SHUTTER AND GLOBAL SHUTTER MODES**

SOFTWARE EVENT NAME	BEHAVIOUR IN RS MODE	BEHAVIOUR IN GS MODE
ExposureStartEvent	Exposure starts for row 1	Exposure starts for all rows
ExposureEndEvent	Exposure ends for row 1	Exposure ends for all rows
RowNExposureStartEvent	Exposure starts for row n	Exposure starts for all rows
RowNExposureEndEvent	Exposure ends for row n	Exposure ends for all rows
BufferOverflowEvent	Image buffer on the camera has been exceeded, causing the current acquisition to stop	
EventsMissedEvent	Acquisition event which the user has registered a call-back for has been missed	

The equivalent of the various TTL Fire signals may also be emulated using the available software events as shown in **Table 12** below.

**TABLE 12: EMULATION OF TTL FIRE SIGNALS USING SOFTWARE EVENTS.**

TTL FIRE SIGNAL	EMULATION USING SOFTWARE EVENTS
Fire 1	ExposureStartEvent and ExposureEndEvent
Fire n	RowNExposureStartEvent and RowNExposureEndEvent
Fire ALL	RowNExposureStartEvent and ExposureEndEvent
Fire ANY	ExposureStartEvent and RowNExposureEndEvent

### 2.7.1.3 EXAMPLE SYSTEM USAGE OF ACQUISITION EVENTS

Compare the following diagrams: The first diagram (**Figure 18**) shows the situation prior to the introduction of the Software Events. In this case the user had to wait until the image frame was completely transferred to the PC before they received any notification that the exposure had completed. This results in a cycle time of approximately 79ms or a frame rate of 12.6fps, for this example. With acquisition software events, and in particular the ExposureEndEvent, the user will be notified as soon as the exposure is complete in advance of readout completion. This in conjunction with faster SW trigger, means that the next acquisition can be started much sooner, resulting in an improvement in frame rate, 25fps. In addition, the Fire ALL signal can be used to control light sources/z-stages. Refer to the SDK3 manual for further information on configuration of software events.

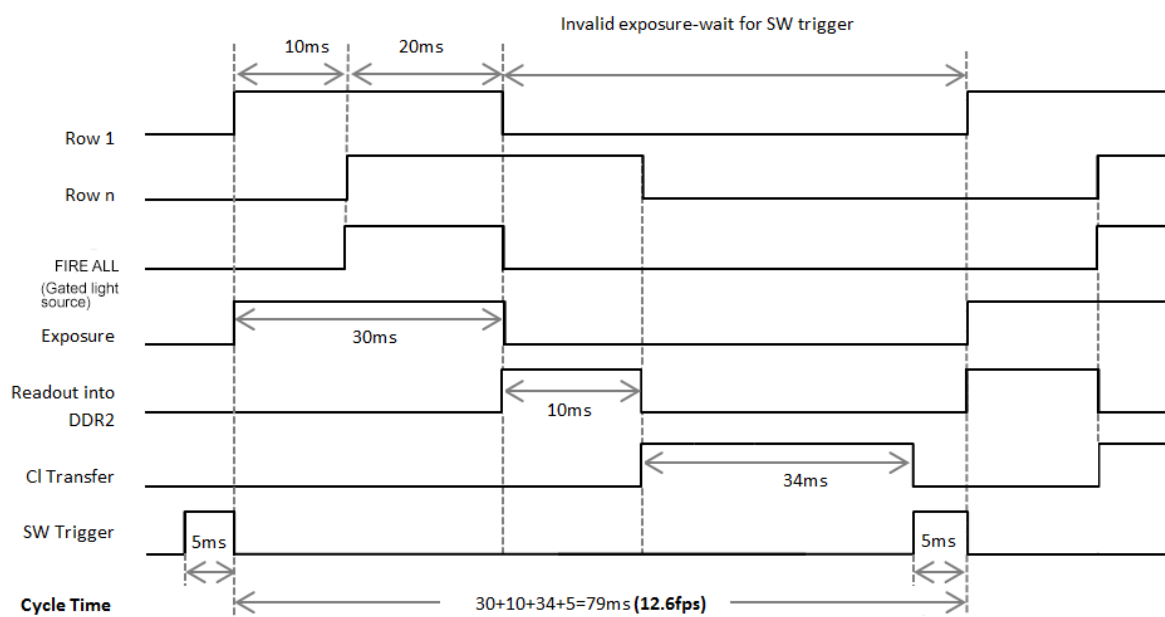

**FIGURE 18: ROLLING SHUTTER - ORIGINAL ACQUISITION USING SW TRIGGER**

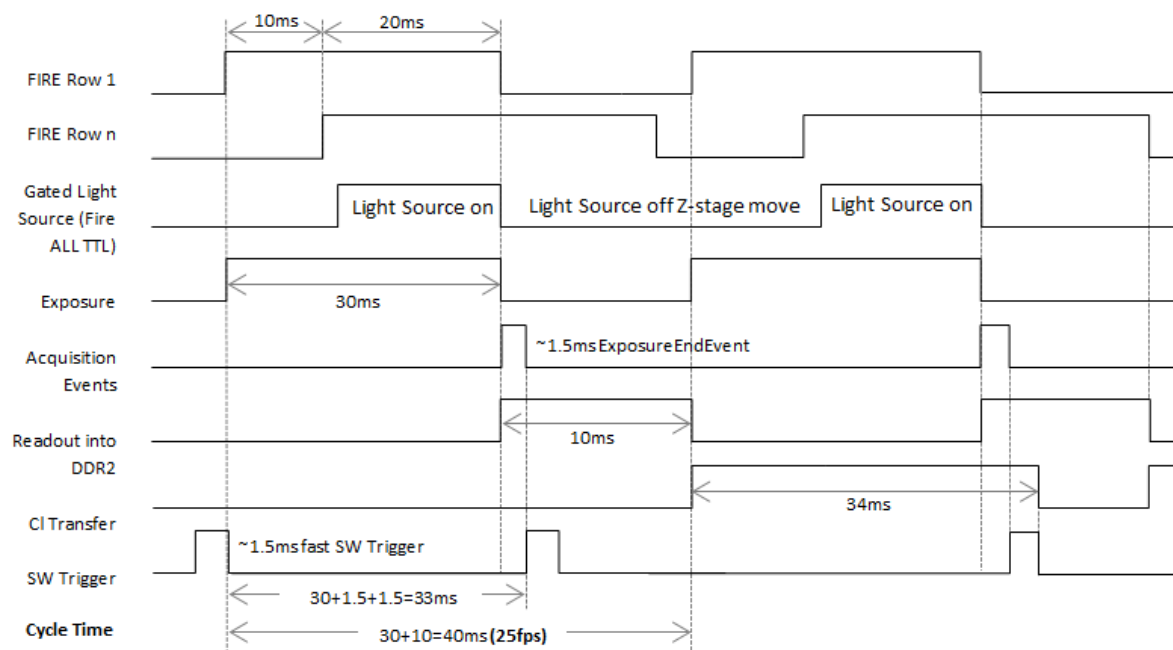

**FIGURE 19: ROLLING SHUTTER - NEW ACQUISITION USING EVENTS AND FASTER SW TRIGGER**

## 2.7.2 ROLLING SHUTTER TRIGGERING MODES

In Rolling Shutter Mode, charge transfer happens on a per row basis:

1. The node is reset for each row
2. A 'reference' measurement taken, and the charge transferred
3. The 'signal' is measured
4. The reference and signal measurements are then subtracted in the analog domain
5. Each following row is processed until the whole sensor is read out

The disadvantage of this is that the start and end exposure time moves by the row read out time for each subsequent row. So whilst each row of pixels is exposed for exactly the same length of time, they do not all start and end at exactly the same time.

The Rolling Shutter signals in the diagrams are as follows:

- **Acquisition Start:** This is an internal pulse purely for illustrative purposes and indicates when the camera receives a command from software to start the pre-programmed acquisition sequence.
- **FIRE:** (Exposure for Row 1): In Rolling Shutter mode, the FIRE output from the camera indicates to the user the exposure time for the first row.
- **FIRE Row n:** (Exposure for Row n): The exposure for Row 2 is delayed by one row time relative to Row 1, Row 3 is delayed by one row time relative to Row 2, etc. for all rows in the frame (up to Row n) - the rows within the selected ROI which are furthest from the sensor centre. This signal is connected to an external output from the camera known as FIRE Row n.
- **FIRE ALL:** The Fire ALL output from the camera indicates when all rows within a frame are being simultaneously exposed.
- **FIRE ANY:** The FIRE ANY output indicates when any row within a frame is being exposed.
- **ARM:** The ARM output from the camera is used in external and software triggering modes to indicate when the camera is ready to accept an incoming trigger. If ARM is low when a trigger event occurs, it will be ignored.
- **Global Clear:** The entire sensor can be held in a global clear state which ensures that there is no charge build-up on the sensor
- **Pre-scan Readout Cycle:** Once an acquisition sequence has been started, the camera is placed into a special cleaning cycle called 'Pre-scan Readout Cycle' which ensures that charge build up on the sCMOS sensor is kept to a minimum while waiting for the trigger event. The Pre-scan Readout Cycle consists of repeatedly reading a virtual row from the sensor. Once the trigger is received, a new exposure phase is initiated.
- **Charge Transfer:** This signal indicates when charge in the pixel is transferred to the measurement node and effectively ends the exposure. The charge is transferred while the pulse is HIGH.  
**NOTE: For clarity this signal is not shown in Rolling Shutter diagrams.**
- **Frame Readout Phase:** This signal shows the period during which the signal frame is read out from the sensor.
- **EXT Start Delay:** This is the delay between the start of the External Trigger pulse and the start of exposure of row 1.

The timing tables accompanying each of the triggering diagrams that follow indicate the exposure and cycle times achievable in each triggering mode. These are based on Frame and Row Periods as shown below in **Table 13**:

**TABLE 13: TIMING PARAMETERS BASED ON SENSOR CLOCK SPEED**

PARAMETER	SENSOR READ OUT SPEED	
	200 MHz	560 MHz
1 Row (2624 clock cycles)	25.41 $\mu$ s	9.24 $\mu$ s
1 Frame ( 2160 rows)	27.44 ms	9.98 ms

'1 Row' is the time taken to read out 2592 pixels. This is currently 2624 clock cycles. The sensor is split into 2 halves with each having an independent data output from the sensor. This means the Frame Period is 1080 rows x 2624 clock cycles. In External and External Start Triggering Modes, the minimum trigger pulse width detected by the camera is shown in **Table 14**:

**TABLE 14: MINIMUM EXT TRIGGER WIDTH**

PARAMETER	SENSOR READ OUT SPEED	
	200 MHz	560 MHz
EXT Trig Pulse Width ( 2 clock cycles)	19.37 ns	7.04 ns

### 2.7.2.1 ROLLING SHUTTER INTERNAL TRIGGERING (NON-OVERLAP MODE)

Internal Trigger Mode allows the user to configure an exposure time and cycle time. For Internal Triggering Non-overlap mode, the exact acquisition sequence depends on the exposure time and cycle time set as shown below.

When the required exposure time is less than the time it takes to read out a frame (Short Exposures), the cycle time is always defined by the time taken to read out a frame. In this scenario, the sensor is configured to continually output signal frames. The exposure time which is set by the user determines the delay between performing an internal rolling row reset and reading out a signal frame.

The following diagrams show the behaviour of TTL outputs 'Fire', 'Fire n', 'Fire ALL' and 'Fire ANY'.

**Fire ALL** indicates the time period within a frame during which all rows are exposing simultaneously.

**Fire ANY** indicates the time period within a frame during which any row is exposing.

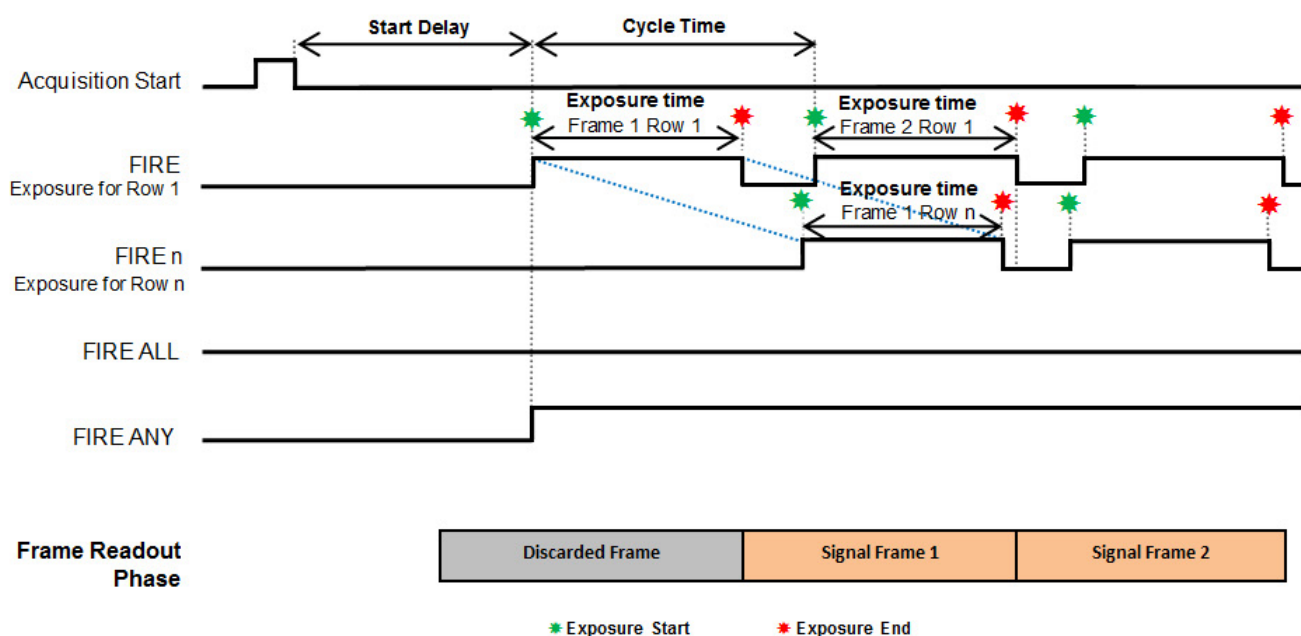

FIGURE 20: ROLLING SHUTTER INTERNAL TRIGGERING - SHORT EXPOSURES

**NOTE: FIRE ALL - Continuous low. FIRE ANY - Continuous high.**

TABLE 15: ROLLING SHUTTER INTERNAL TRIGGERING - SHORT EXPOSURES TIMING PARAMETERS

PARAMETER	MINIMUM	MAXIMUM
Exposure Time	1 Row	1 Frame
Cycle Time (1/Frame Rate)	1 Frame	1 Frame
Acquisition Start Delay	-	1 Frame

**TABLE 16: EXAMPLE TIMINGS FOR SHORT EXPOSURE AND FULL FRAME READOUT.**

PARAMETER	SENSOR CLOCK RATE			
	200 MHz		560 MHz	
	Min	Max	Min	Max
Exposure Time	25.41 $\mu$ s	28.33 ms	9.24 $\mu$ s	10.1 ms
Cycle Time (1/Frame Rate)	27.44 ms	28.33 ms	9.98 ms	10.1 ms
Acquisition Start Delay	-	28.33 ms	-	10.1 ms

Long Exposures- when the user enters an exposure time that is greater than a frame read out is shown in **Figure 21** below. Initially, the entire sensor is held in a global clear state to ensure that there is no charge build-up on the sensor. Global Clear goes LOW and a frame read out is initiated. This frame is discarded as it does not contain the correct exposure period. Reading out a frame effectively begins a new exposure. When the exposure period has completed, a signal frame read out phase begins. When the frame has been read out completely, the Global Clear is held HIGH until the user-defined cycle time is achieved.

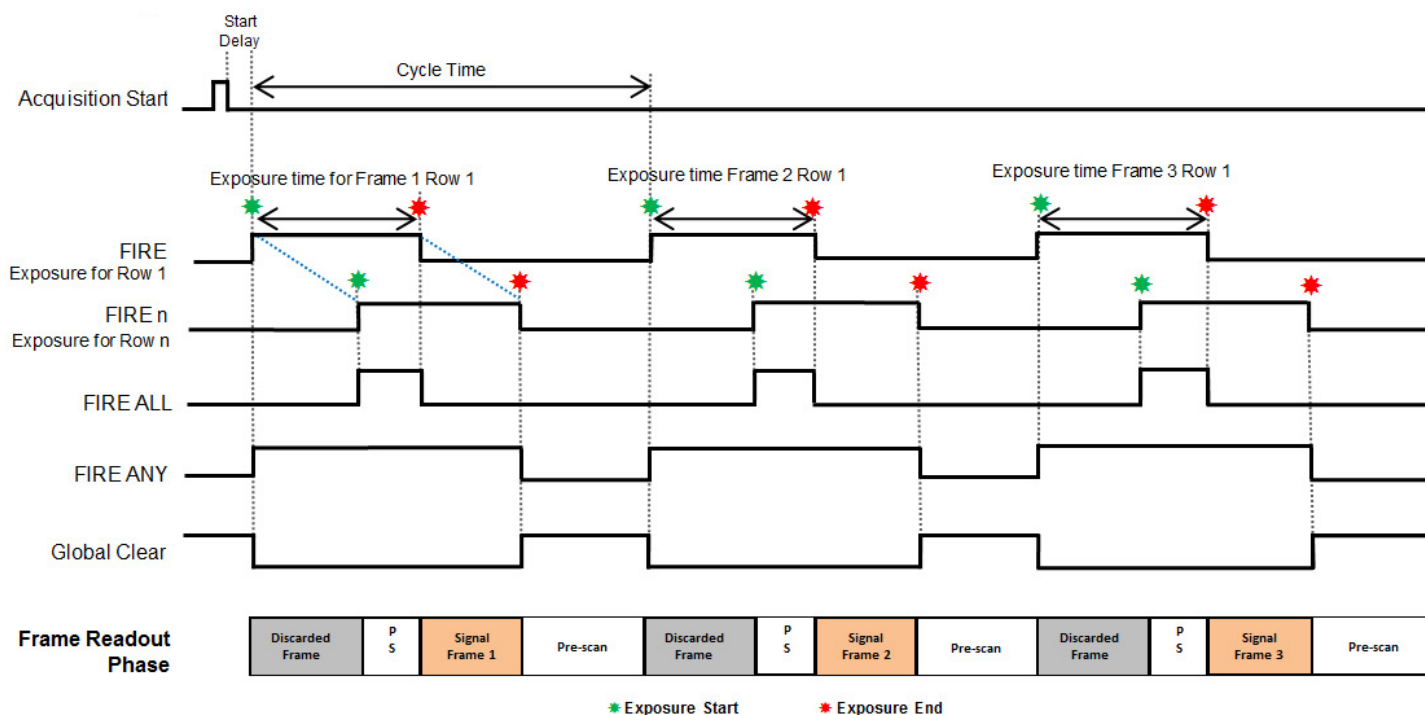

**FIGURE 21: ROLLING SHUTTER INTERNAL TRIGGERING (LONG EXPOSURES)**

**TABLE 17: ROLLING SHUTTER INTERNAL TRIGGERING (LONG EXPOSURES) TIMING PARAMETERS**

PARAMETER	MINIMUM	MAXIMUM
Exposure	1 Frame + 1 Row	$2^{31}$ Rows
Cycle Time (1/Frame Rate)	Exposure + 1 Frame + 1 Row	20,000 s
Acquisition Start Delay	-	1 Row



### 2.7.2.2 ROLLING SHUTTER INTERNAL TRIGGERING (OVERLAP MODE)

Internal Triggering in Overlap Mode allows the user to perform an exposure and acquire images from the sensor simultaneously. This is achieved by starting a new exposure while the previous frames exposure is being read out from the sensor. The cycle time is the same as the exposure time entered by the user in this scenario.

Initially, the entire sensor is held in a global clear state to ensure that there is no charge build-up on the sensor. Global Clear goes LOW and the first frame read out is initiated. This frame is discarded as it does not contain the correct exposure period. Reading out this first frame effectively begins the first exposure. When the exposure period has completed, a signal frame read out phase begins. As each row is read out, the new exposure for that row begins.

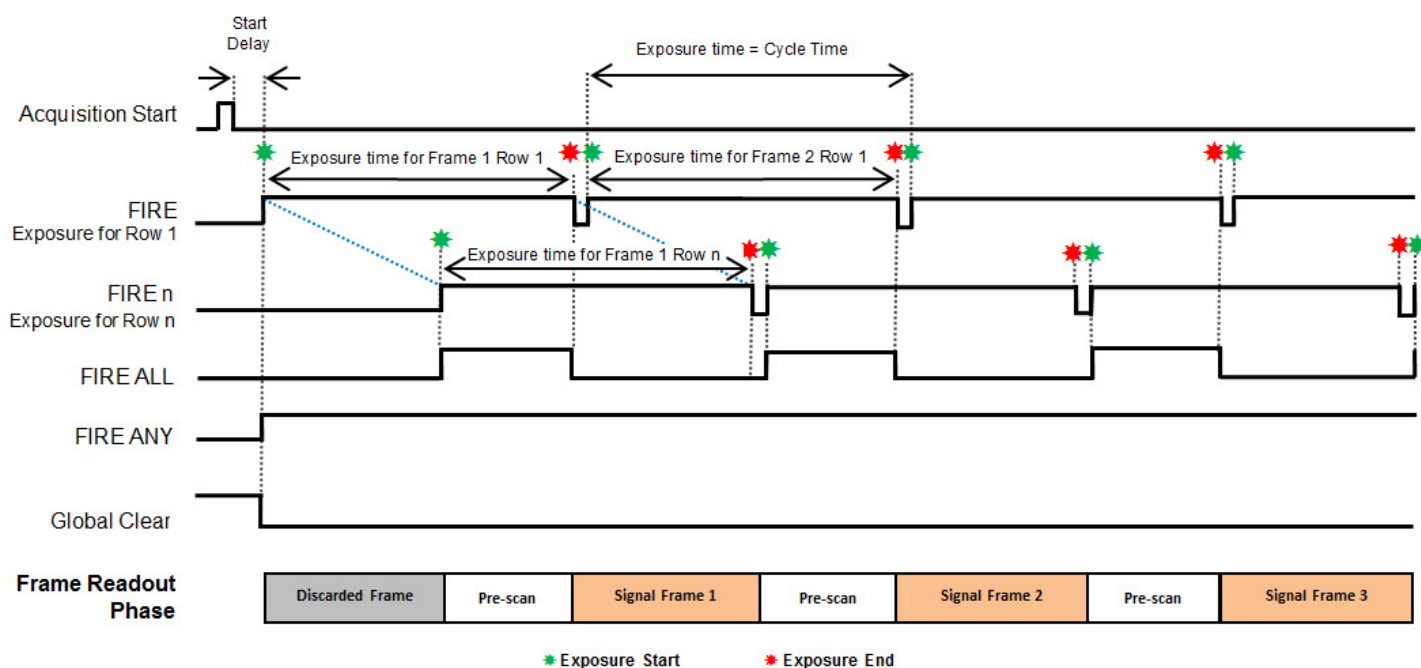

FIGURE 22: ROLLING SHUTTER INTERNAL TRIGGERING (OVERLAP MODE) (LONG EXPOSURES)

TABLE 18: ROLLING SHUTTER INTERNAL TRIGGERING (OVERLAP MODE) TIMING PARAMETERS

PARAMETER	MINIMUM	MAXIMUM
Exposure	1 Frame + 1 Row	2 <sup>31</sup> Rows
Cycle Time (1/Frame Rate)	Exposure Time	Exposure Time
Acquisition Start Delay	-	1 Row
FIRE low period	20 Sensor Speed Clock Cycles	-

### 2.7.2.3 ROLLING SHUTTER SOFTWARE TRIGGERING - SHORT EXPOSURES

When the required exposure time is less than the time it takes to read out a frame (Short Exposures), the cycle time is always defined by the time taken to read out a frame. In this scenario, the sensor is configured to continually output signal frames. The exposure time which is set by the user determines the delay between performing an internal rolling row reset and reading out a signal frame.

Once the SW trigger event is detected, Global Clear goes LOW. Due to the continual output of frames, a frame is discarded as it does not contain the correct exposure period. When the exposure period has completed, a signal frame read out phase begins.

When the frame has been read out completely, a new acquisition can begin on the detection of the next SW trigger event.

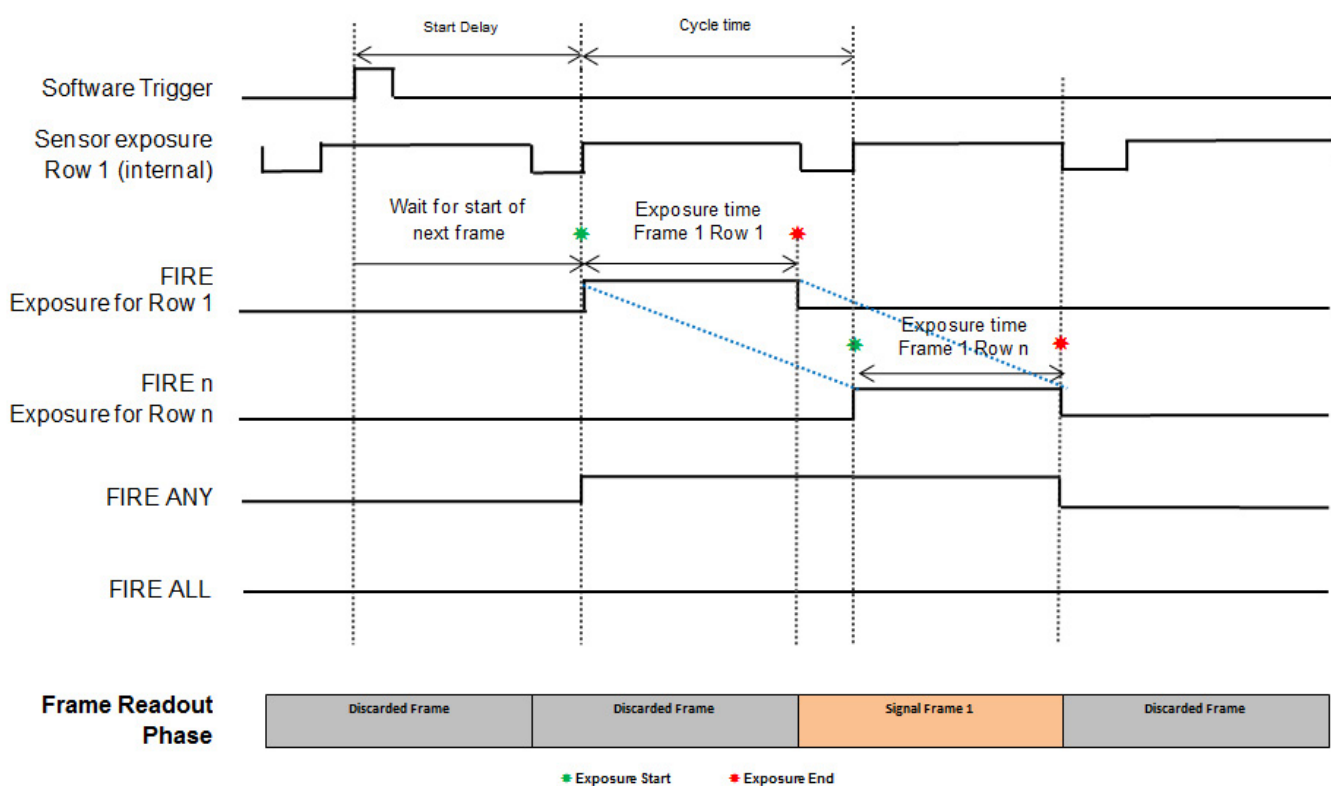

FIGURE 23: ROLLING SHUTTER SOFTWARE TRIGGER (SHORT EXPOSURES)

TABLE 19: ROLLING SHUTTER SOFTWARE TRIGGERING TIMING PARAMETERS

PARAMETER	MINIMUM	MAXIMUM
Exposure	1 Row	1 Frame
Cycle Time (1/Frame Rate)	2 Frames	2 Frames
External Start Delay	0	1 Frame
EXT Trig Pulse Width	-	-

### 2.7.2.4 ROLLING SHUTTER EXTERNAL / SOFTWARE TRIGGERING (NON-OVERLAP MODE)

In this section, both External and Software Trigger are described in the same diagram as the acquisition sequence is the same. The trigger event can either be from the EXT Trigger input or sent via software. While waiting on the trigger event, the sensor is put into a “pre-scan read out cycle” and is held in a Global Clear State which ensures that charge build up on the sensor is kept to a minimum while waiting for the trigger event. The ARM signal is asserted to indicate it is ready to detect an incoming trigger input.

Once the trigger event is detected, Global Clear goes LOW and a frame read out is initiated. This frame is discarded as it does not contain the correct exposure period. Reading out a frame effectively begins a new exposure. When the exposure period has completed, a signal frame read out phase begins. When the frame has been read out completely, the Global Clear is held HIGH until the next trigger event is detected.

The external trigger is fed via the EXT Trigger input on the I/O Connector on the camera head.

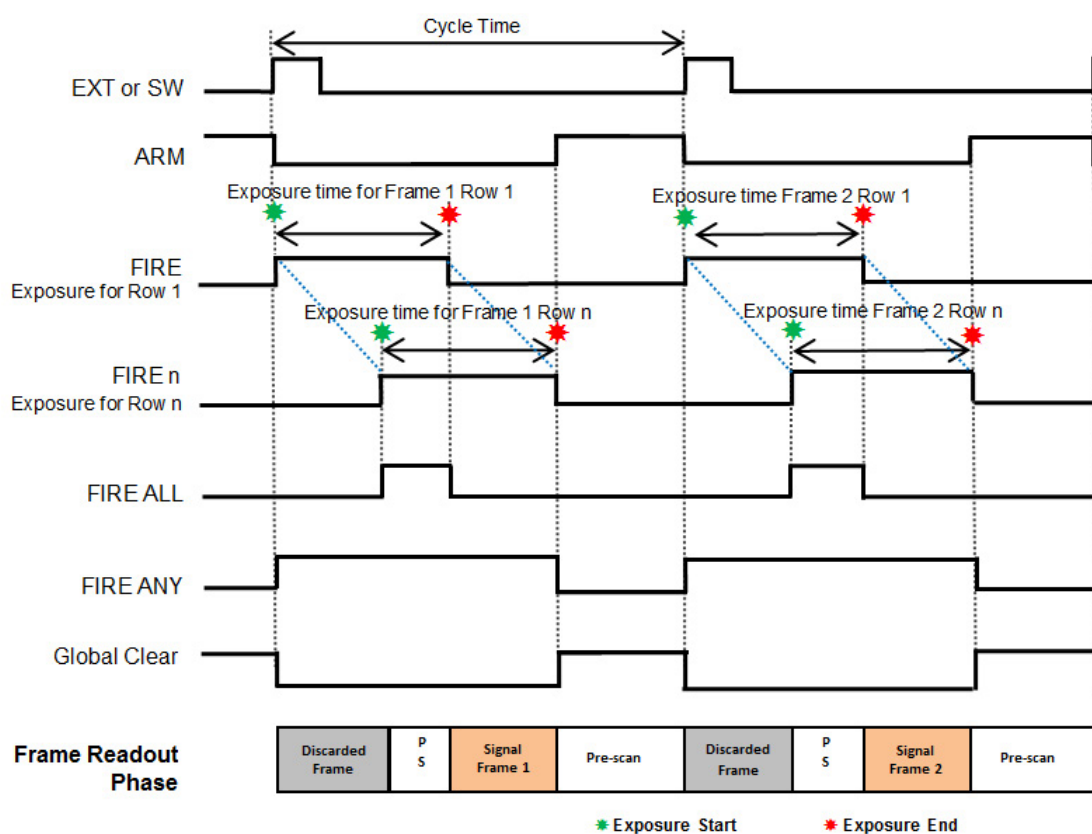

FIGURE 24: ROLLING SHUTTER EXTERNAL/SOFTWARE TRIGGER (LONG EXPOSURES)

TABLE 20: ROLLING SHUTTER EXTERNAL/SOFTWARE TRIGGERING TIMING PARAMETERS

PARAMETER	MINIMUM	MAXIMUM
Exposure	1 Frame + 1 Row	2 <sup>31</sup> Rows
Cycle Time (1/Frame Rate)	Exposure + 1 Frame + 1 Row	-
External Start Delay	0	1 Row
EXT Trig Pulse Width	2 Sensor Speed Clock Cycles	-

### 2.7.2.5 ROLLING SHUTTER EXTERNAL EXPOSURE TRIGGERING (NON-OVERLAP MODE)

While waiting on the trigger event, the sensor held in a global clear state and is put into a “pre-scan read out cycle”. On detection of the trigger event, Global Clear goes **LOW** and a frame read out is initiated. This frame is discarded as it does not contain the correct exposure period. Reading out a frame effectively begins a new exposure. When the external trigger input goes **LOW**, a signal frame read out phase begins. When the frame has been read out completely, the Global Clear is held **HIGH** until the next trigger event is detected.

The **external trigger pulse width** defines the exposure time for all rows, but is only coincident with the exposure time for Row 1. The exposure for Row 2 will be delayed by one row time relative to Row 1 and so forth.

The **period of the external trigger pulse** defines the overall cycle time. If the width of the trigger event is less than the frame read out time, the falling edge will be missed and a subsequent falling edge will be required to end the exposure.

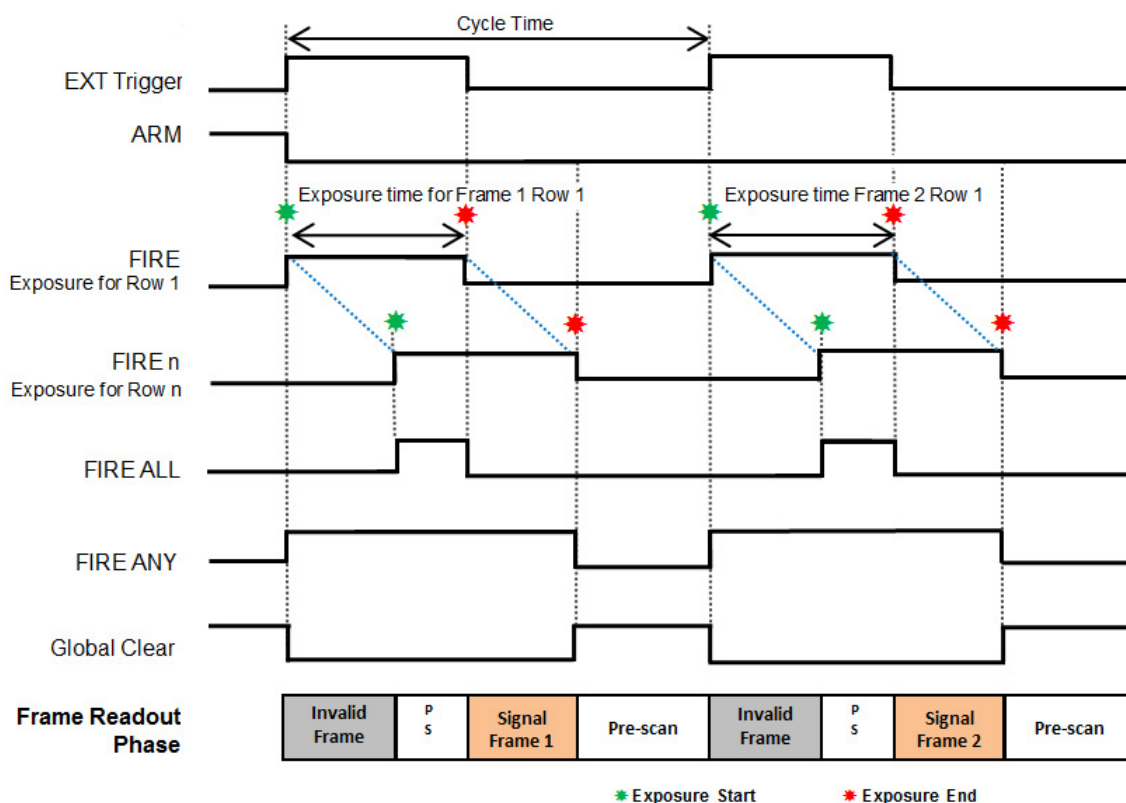

FIGURE 25: ROLLING SHUTTER EXTERNAL EXPOSURE TRIGGERING (NON-OVERLAP MODE) (LONG EXPOSURES)

TABLE 21: ROLLING SHUTTER EXTERNAL EXPOSURE TRIGGERING (NON-OVERLAP MODE) TIMING PARAMETERS

PARAMETER	MINIMUM	MAXIMUM
Exposure	1 Frame + 1 Row	2 <sup>31</sup> Rows
Cycle Time (EXT Trig Period)	Exposure + 1 Frame + 1 Row	-
External Start Delay	0	1 Row
EXT Trig Pulse Width	1 Frame + 1 Row	2 <sup>31</sup> Frames

### 2.7.2.6 ROLLING SHUTTER EXTERNAL EXPOSURE TRIGGERING (OVERLAP MODE)

In overlap mode, every positive edge of an external trigger will trigger a frame read out and start a new exposure for the next frame. The period of external trigger pulse defines exposure and cycle time for each frame read out.

While waiting on the positive edge of the external trigger, the sensor held in a global clear state and is put into a “pre-scan read out cycle”. On detection of the positive edge, Global Clear goes LOW and a frame read out is initiated. This frame is discarded as it does not contain the correct exposure period. Reading out this first frame effectively begins the first exposure. When the next positive edge of the external trigger is detected, a signal frame read out phase begins. As each row is read out, the new exposure for that row begins.

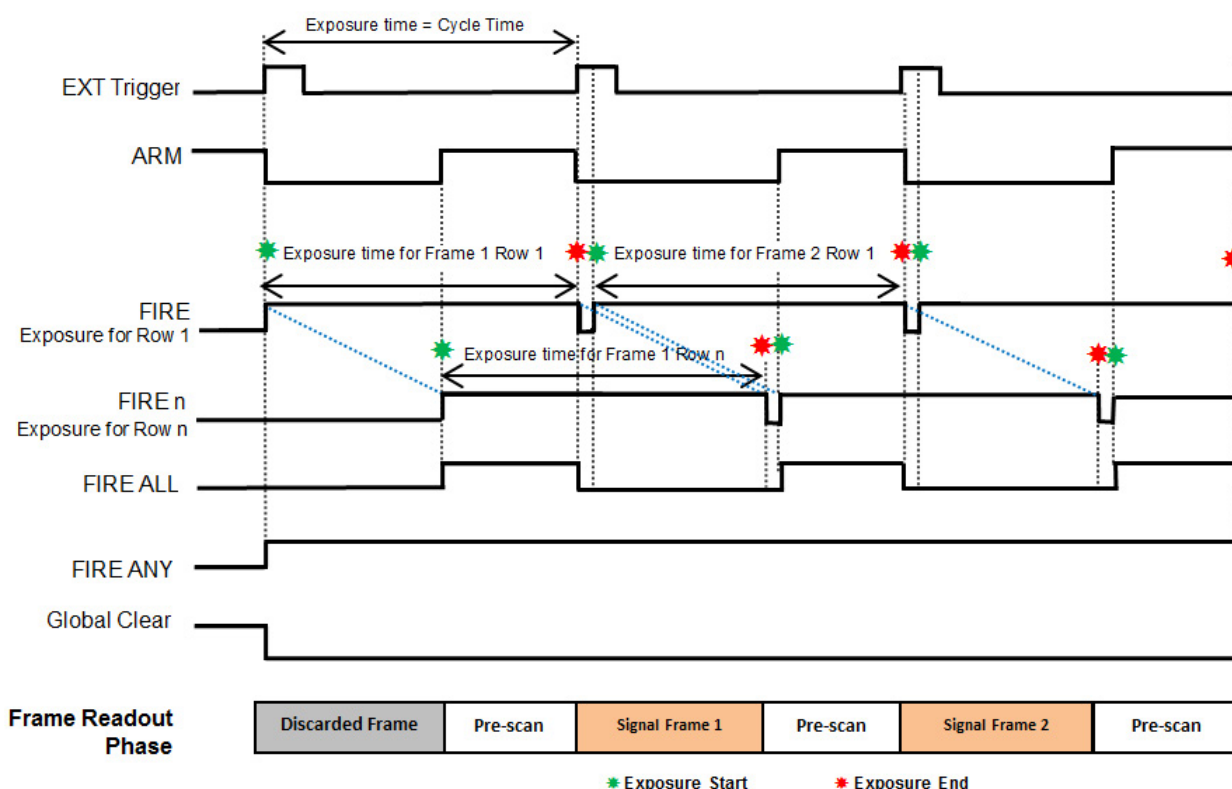

FIGURE 26: ROLLING SHUTTER EXTERNAL EXPOSURE TRIGGERING (OVERLAP MODE) (LONG EXPOSURES)

TABLE 22: ROLLING SHUTTER EXTERNAL EXPOSURE TRIGGERING (OVERLAP MODE) TIMING PARAMETERS

PARAMETER	MINIMUM	MAXIMUM
Exposure	1 Frame + 1 Row	2 <sup>31</sup> Rows
Cycle Time (EXT Trig Period)	Exposure	Exposure
External Start Delay	0	1 Row
EXT Trig Pulse Width	2 Sensor Speed Clock Cycles	-
FIRE low period	20 Sensor Speed Clock Cycles	-

### 2.7.2.7 ROLLING SHUTTER EXTERNAL START TRIGGERING

In this mode the camera will wait for a single external trigger event. Once this external trigger event is detected, the camera will progress as if the camera was in internal trigger mode (see **Section 2.7.2.1 and 2.7.2.2**). The ARM signal indicates to the user when the camera is ready to detect an External Start Trigger. **Figure 27** shows the External Start used in Non-overlap Mode, Long Exposure. The delay from the External Trigger to start of exposure in this case is 1 Row.

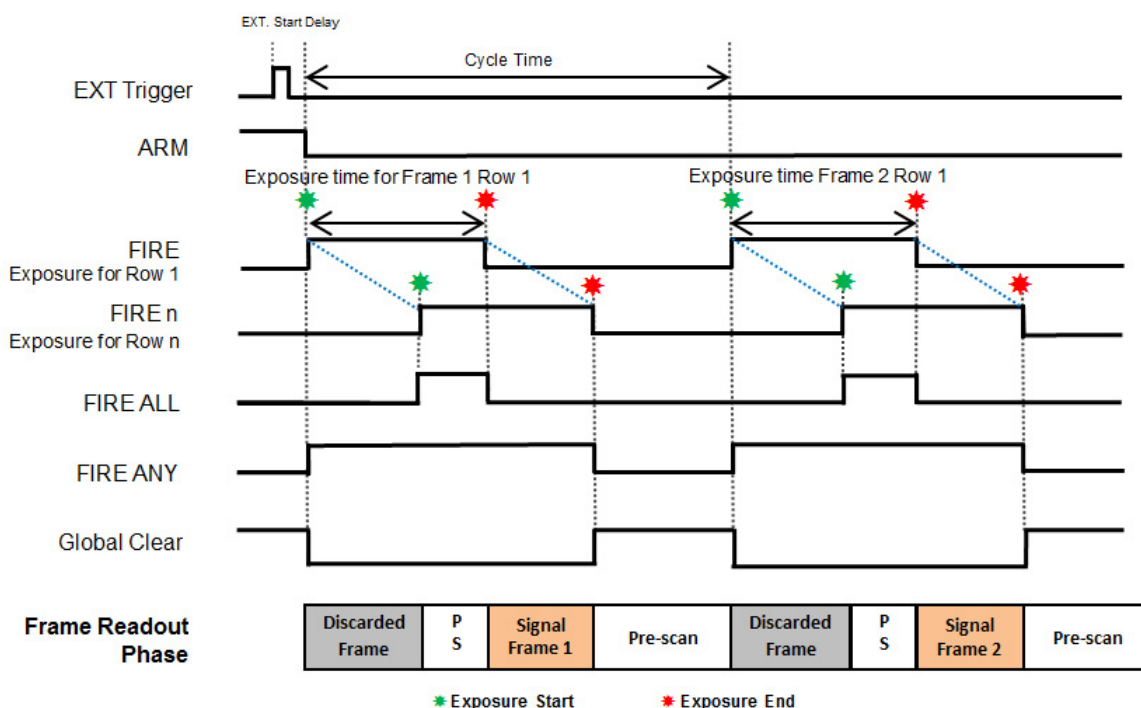

**FIGURE 27: ROLLING SHUTTER EXTERNAL START TRIGGERING (NON-OVERLAP) (LONG EXPOSURES)**

**External Start Delay** This is the delay between the start of the External Trigger pulse and the start of exposure of row 1. The maximum delay that can occur depends on the exposure time set:

**TABLE 23: ROLLING SHUTTER EXTERNAL START TRIGGERING TIMING PARAMETERS**

EXPOSURE SETTING	MAXIMUM EXTERNAL START DELAY
Exposure Time $\leq$ 1 Frame	2 Frames (overlap off only)
Exposure Time $>$ 1 Frame	1 Row

### 2.7.2.8 ROLLING SHUTTER TRIGGERING CONSTRAINTS

The table below shows a summary of constraints when operating in Rolling Shutter mode:

**TABLE 24: ROLLING SHUTTER TRIGGERING MODES CONSTRAINTS SUMMARY**

ROLLING SHUTTER TRIGGERING MODES		EXPOSURE RANGE	MAX TRIGGER JITTER	MIN TRIGGER PULSE WIDTH	FAST EXPOSURE SWITCHING SUPPORTED
Internal	User settable exposure time. Cycle Time is read out time for short exposures. User settable Cycle time for long exposures	Short Exp (1 Row to 1 Frame)	-	-	x
		Long Exp (1 Frame + 1 Row) to 2 <sup>31</sup> Rows	-	-	√
Internal Overlap	User settable exposure time. Cycle Time is exposure time	(1 Frame + 1 Row) to 2 <sup>31</sup> Rows	-	-	√
External	Exposure time user settable. Cycle Time controlled via period of external trigger pulse	(1 Frame + 1 Row) to 2 <sup>31</sup> Rows	1 Row	2 Sensor Clocks	√
Software	Exposure time user settable. Cycle Time controlled via software trigger function	Short Exp (1 Row to 1 Frame)	1 Row	2 Sensor Clocks	√
		Long Exp (1 Frame + 1 Row) to 2 <sup>31</sup> Rows			
External Exposure Non-overlap	Exposure Time controlled by width of external trigger pulse. Cycle Time controlled via period of external trigger pulse.	(1 Frame + 1 Row) to 2 <sup>31</sup> Rows	1 Row	1 Frame + 1 Row	x
External Exposure Overlap	Exposure time controlled by period of external trigger pulse	(1 Frame + 1 Row) to 2 <sup>31</sup> Rows	1 Row	2 Sensor Clocks	x
External Start	User settable exposure time. Cycle Time is read out time for short exposures. User settable Cycle Time for long exposures	Short Exp (1 Row to 1 Frame)	2 Frames	2 Sensor Clocks	x
		Long Exp (1 Frame + 1 Row) to 2 <sup>31</sup> Rows	1 Row		√

#### NOTES:

1. Exposure Time granularity for all modes is sensor row based so the exposure time in the dialog will always be rounded to the nearest integral number of row readout times.
2. 1 Row is the time taken to perform a full row readout (2624 clock cycles), i.e. depends on readout rate.
3. 1 Frame is the image height of a sensor half, defined in Rows and determined by the ROI configured, e.g. full frame = 1080. This is the number of rows that is read out by each sensor half. The frame readout time for any ROI can be requested via SDK function. (Refer to the SDK3 User Guide for details).
4. A short exposure is referred to an exposure that is less than a Frame Readout Time. (Depends on ROI selected).
5. A long exposure is referred to an exposure time that is greater than a Frame Readout Time. (Depends on ROI selected).
6. Image acquisition must be stopped to change between short and long exposures. Fast Exposure Switching can occur in the triggering modes shown above but the exposure time is then limited to the exposure range shown for each sequence.

### 2.7.3 GLOBAL SHUTTER TRIGGERING MODES

Global Shutter mode, which can also be thought of as a ‘snapshot’ exposure mode, means that all pixels of the array are exposed simultaneously. Before the exposure begins, all pixels in the array are cleared of charge using the Global Clear. At the start of the exposure each pixel simultaneously begins to collect charge and is allowed to do so for the duration of the exposure time. At the end of exposure, each pixel transfers the accumulated charge simultaneously to its read out node. Global Shutter requires a reference frame to be read out of the sensor in addition to the signal frame, therefore effectively halving the frame rate that would have been achieved in Rolling Shutter mode.

The Global Shutter signals shown in the diagrams are as follows:

- **Acquisition Start:** This is an internal pulse purely for illustrative purposes and indicates when the camera receives a command from software to start the pre-programmed acquisition sequence.
- **FIRE:** In Global Shutter mode, the FIRE output indicates the exposure period, which is identical for all pixels. This pulse is available to the user via the FIRE output pin.  
**NOTE: In Global Shutter Mode the behaviour of FIRE Row n, FIRE ALL and FIRE ANY are identical to that of FIRE and therefore not shown in the diagrams.**
- **ARM:** The ARM output from the camera is used for external and software triggering modes to indicate when the camera is ready to accept another incoming trigger pulse.
- **Global Clear:** Global Shutter uses Global Clear to begin a new exposure. When this pulse is HIGH, charge is drained from every pixel thus preventing the accumulation of charge on the sensor. When the pulse is LOW, any photo-electrons generated are accumulating within the pixels, ready for transfer to the sense node for subsequent readout. The falling edge indicates the start of an exposure.
- **Charge Transfer:** This signal indicates when charge in the pixel is transferred to the measurement node and effectively ends the exposure. The charge is transferred while the pulse is HIGH and is shown in the diagrams to indicate there is a specified time between reading out the reference and signal frames.
- **Frame Read Out Phase:** This signal indicates when reference and signal frames are read out of the sensor.
- **Interframe:** The interframe defines the minimum time taken between reference and signal frame readouts

The timing tables accompanying each of the triggering diagrams that follow indicate the exposure and cycle times achievable in each triggering mode. These are based on Frame and Row Periods as shown below:

**TABLE 25: TIMING PARAMETERS BASED ON SENSOR CLOCK SPEED FOR GLOBAL SHUTTER**

PARAMETER	SENSOR READ OUT RATE	
	200 MHz	560 MHz
1 Row (2624 clock cycles)	25.41 $\mu$ s	9.37 $\mu$ s
1 Full Frame ( 2160 rows)	27.44 ms	9.98 ms
Charge Transfer Time	5.5 $\mu$ s	2 $\mu$ s
Interframe (9 Rows)	228.7 $\mu$ s	83.2 $\mu$ s

1 Row is the time taken to perform 2624 clock cycles. The sensor is split into 2 halves with each having an independent data output from the sensor. Therefore, the Frame Period is 1080 rows x 2624 clock cycles.



### 2.7.3.1 GLOBAL SHUTTER INTERNAL TRIGGERING (NON-OVERLAP MODE)

In Internal non-overlap modes, a new exposure does not start until the previous exposure has been read out. The exact acquisition sequence depends on the exposure time. The two scenarios are shown in **Figure 28** below and **Figure 29**. If the exposure time is less than the time it takes to read out a frame, then the exposure period occurs between reading out the reference and the signal frames as shown in **Figure 28**.

In this scenario, the reference frame is read out before the Global Clear is performed. The negative edge of the Global Clear begins an exposure. After the user-defined exposure time, the Charge Transfer pulse goes HIGH to transfer charge from all pixels in the sensor. The signal frame is then read out.

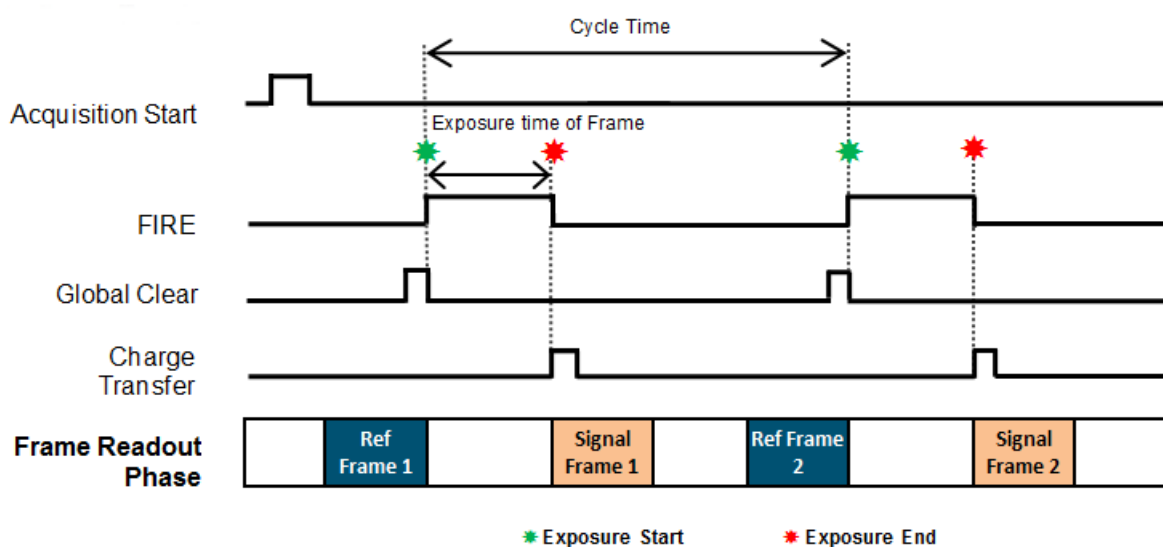

FIGURE 28: GLOBAL SHUTTER INTERNAL TRIGGERING – SHORT EXPOSURES

TABLE 26: GLOBAL SHUTTER INTERNAL TRIGGERING - SHORT EXPOSURES TIMING PARAMETERS

PARAMETER	MINIMUM	MAXIMUM
Exposure	1 Row	1 Frame + 3 Rows
Cycle Time (1/Frame Rate)	Exposure + 2 Frames + 2 Interframes	Exposure + 2 Frames + 2 Interframes
Acquisition Start Delay	0	1 Frame

If the exposure time is greater than a frame read out time, the exposure starts first by pulsing the Global Clear. The reference frame is read out during the exposure such that the end of the reference read out is coincident with the end of the exposure. The Charge Transfer pulse then goes HIGH to transfer charge from all pixels in the sensor. Finally, the signal frame is then read as shown in Figure 29.

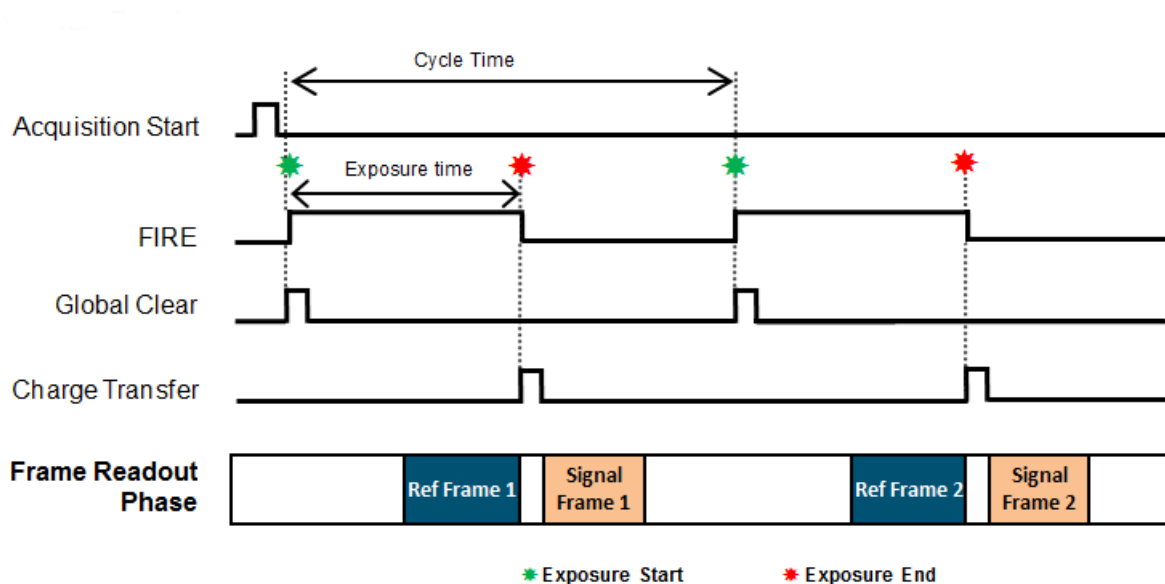

FIGURE 29: GLOBAL SHUTTER INTERNAL TRIGGERING – LONG EXPOSURES

TABLE 27: GLOBAL SHUTTER INTERNAL TRIGGERING - LONG EXPOSURES TIMING PARAMETERS

PARAMETER	MINIMUM	MAXIMUM
Exposure	1 Frame + 4 Rows	2 <sup>31</sup> Rows
Cycle Time (1/Frame Rate)	Exposure + 1 Frames + 1 InterFrame + 6 Rows	20,000 s
Acquisition Start Delay	0	1 Row

### 2.7.3.2 GLOBAL SHUTTER INTERNAL TRIGGERING (OVERLAP MODE)

In Internal Triggering with Overlap Mode on, the read out of an exposure overlaps with the next exposure. This allows the user to maximize the frame rate for a given exposure time. The absolute maximum frame rate achievable is the time taken to read out both the Reference and Signal Frame from the sensor. As in Non-Overlap Mode, the user has control over the exposure time and cycle time.

In this scenario, the exposure begins by pulsing the Global Clear. The reference frame is read out during the exposure such that the end of the reference read out is coincident with the end of the exposure. The Charge Transfer pulse then goes HIGH to transfer charge from all pixels in the sensor. The signal frame is then read out. During this read out, a new exposure begins by pulsing the Global Clear.

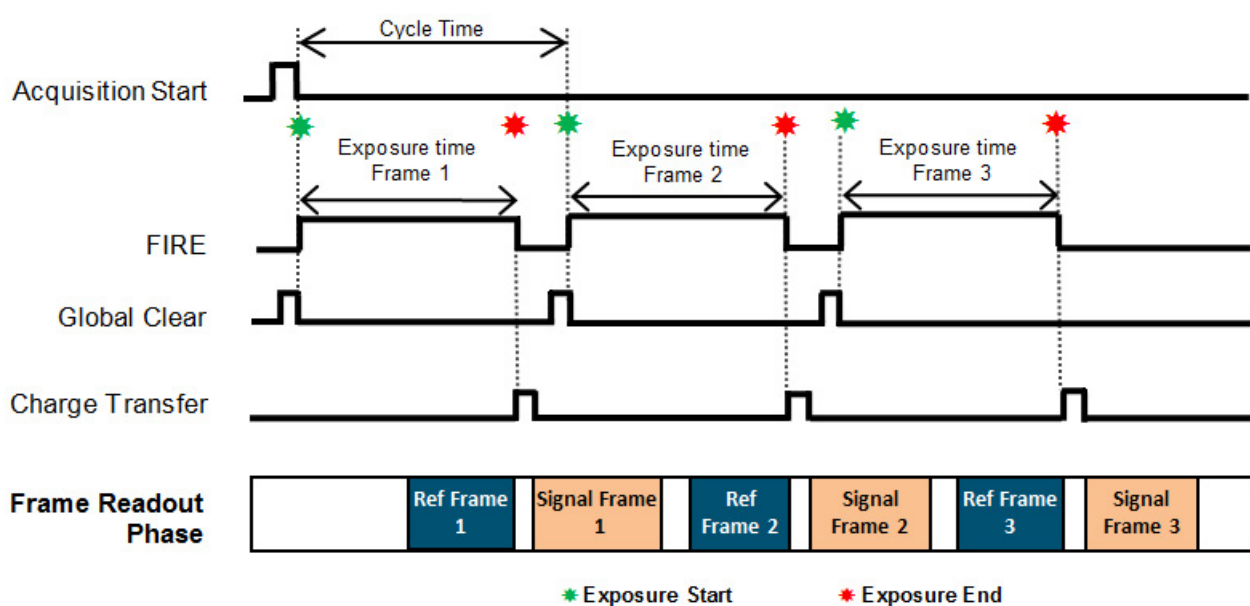

FIGURE 30: GLOBAL SHUTTER INTERNAL TRIGGERING (OVERLAP MODE)

TABLE 28: GLOBAL SHUTTER INTERNAL TRIGGERING (OVERLAP MODE) TIMING PARAMETERS - CYCLE TIME DEPENDENCY ON EXPOSURE

PARAMETER	MINIMUM	MAXIMUM
Exposure	1 Frame + 1 InterFrame + 1 Row	2 Frames + 1 InterFrame
Cycle Time (1/Frame Rate)	2 Frames + 2 InterFrames + 1 Row	2 Frames + 2 InterFrames + 1 Row
Exposure	2 Frames + 1 InterFrame + 1 Row	$2^{31}$ Rows
Cycle Time (1/Frame Rate)	Exposure + 1 InterFrame + 1 Row	$2^{31}$ Rows
Acquisition Start Delay	0	1 Row

**NOTE:** The table shows that the cycle time depends on the exposure selected – within the exposure range detailed in the first row the cycle time is constant, however for exposures of (2 Frames + 1 Interframe + 1 Row) or longer the cycle time increases with exposure.

### 2.7.3.3 GLOBAL SHUTTER EXTERNAL/SOFTWARE TRIGGERING

In this section, both External and Software Trigger are described in the same diagram as the acquisition sequence is the same. The trigger event can either from the EXT input or sent via software. While waiting on the trigger event, the sensor is put into a “pre-scan read out cycle”. On detection of the trigger, the Global Clear line is pulsed to clear the charge from the sensor. The exposure period then starts and lasts for the user defined exposure time. The reference frame is read out during the exposure such that the end of the reference read out is coincident with the end of the exposure. The Charge Transfer pulse then goes HIGH to transfer charge from all pixels in the sensor. Finally, the signal frame is then read. The camera then returns to the “pre-scan read out cycle” awaiting for the next trigger. **The timing sequence for non-overlap mode is illustrated in Figure 31.**

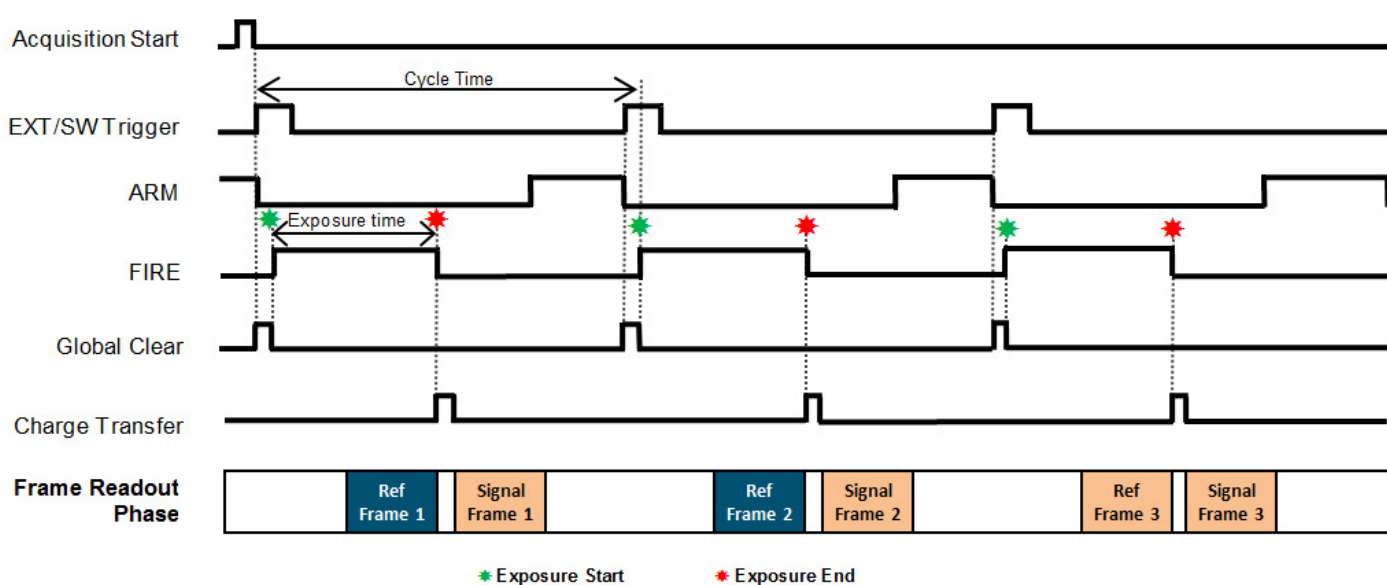

FIGURE 31: GLOBAL SHUTTER EXTERNAL/SOFTWARE TRIGGERING (NON-OVERLAP MODE)

TABLE 29: GLOBAL SHUTTER EXTERNAL/SOFTWARE TRIGGERING TIMING PARAMETERS (NON-OVERLAP MODE)

PARAMETER	MINIMUM	MAXIMUM
Exposure	1 Frame + 4 Rows	2 <sup>31</sup> Rows
Cycle Time (1/Frame Rate)	Exposure + 1 Frame + 1 InterFrame + 5 Rows	-
Trigger Delay	1 Row	2 Rows
EXT Trig Pulse Width	2 Sensor Speed Clock Cycles	-

With overlap enabled (shown in **Figure 32**), the camera can accept a trigger to begin the next exposure prior to the signal frame readout completing. Note that external triggers will be missed if it is too fast- refer to **Table 30** for guidelines on time restrictions.

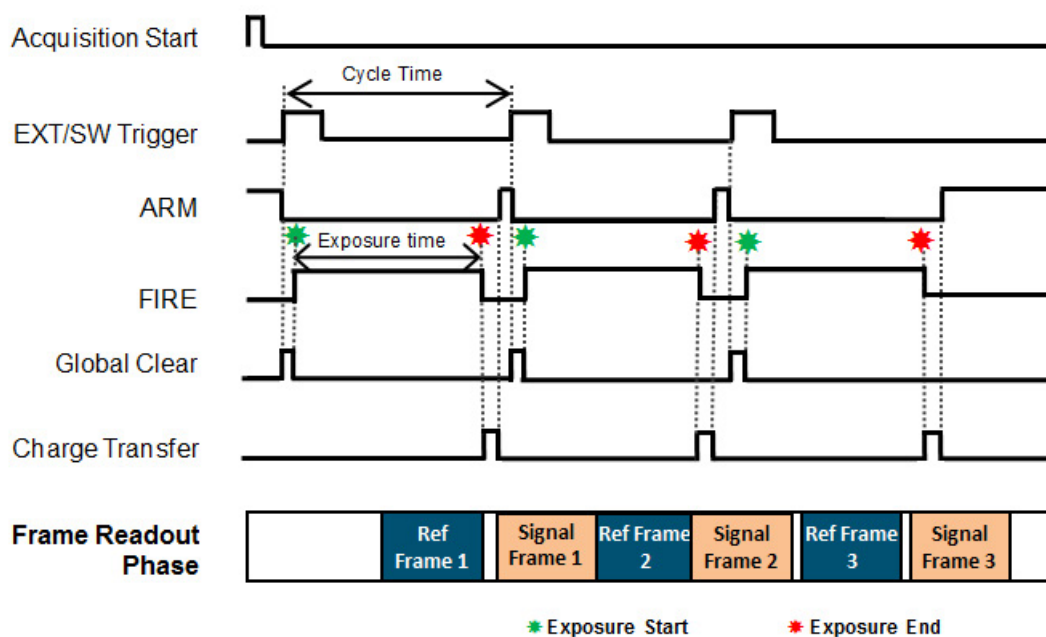

FIGURE 32: GLOBAL SHUTTER EXTERNAL/SOFTWARE TRIGGERING (OVERLAP MODE)

TABLE 30: GLOBAL SHUTTER EXTERNAL/SOFTWARE TRIGGERING TIMING PARAMETERS (OVERLAP ON) - CYCLE TIME DEPENDENT ON EXPOSURE

PARAMETER	MINIMUM	MAXIMUM
Exposure	1 Frame + 1 InterFrame + 1 Row	2 Frames + 1 InterFrame + 4 Rows
Cycle Time (1/Frame Rate)	2 x (1 Frame + 1 InterFrame + 1 Row)	
Exposure	2 Frames + 1 InterFrame + 5 Rows	2 <sup>31</sup> Rows
Cycle Time (1/Frame Rate)	Exposure + 1 InterFrame + 2 Rows	
Trigger Delay	1 Row	2 Rows
EXT Trig Pulse Width	2 Sensor Speed Clock Cycles	-

**NOTE:** The table shows that the cycle time depends on the exposure selected – within the exposure range detailed in the first row the cycle time is constant, however for exposures of (2 Frames + 1 InterFrame + 5 Rows) or longer the cycle time increases with exposure.

### 2.7.3.4 GLOBAL SHUTTER EXTERNAL EXPOSURE TRIGGERING (NON-OVERLAP MODE)

While waiting on the trigger event, the sensor is put into a “pre-scan read out cycle”. On detection of the trigger event, the Global Clear is pulsed to clear the charge from the sensor. The exposure period then starts and lasts for the width of the External Trigger. During the exposure period, a reference frame is read. The reference frame is read immediately as the system has no method to know how long the External Trigger will be HIGH for. When the external trigger input goes LOW, the exposure ends by transferring the charge in all pixels simultaneously to the measurement node. A signal frame read out then begins. The period of the external trigger pulse defines the overall cycle time. If the width of the trigger event is less than the frame read out time, the falling edge will be missed and a subsequent falling edge will be required to end the exposure.

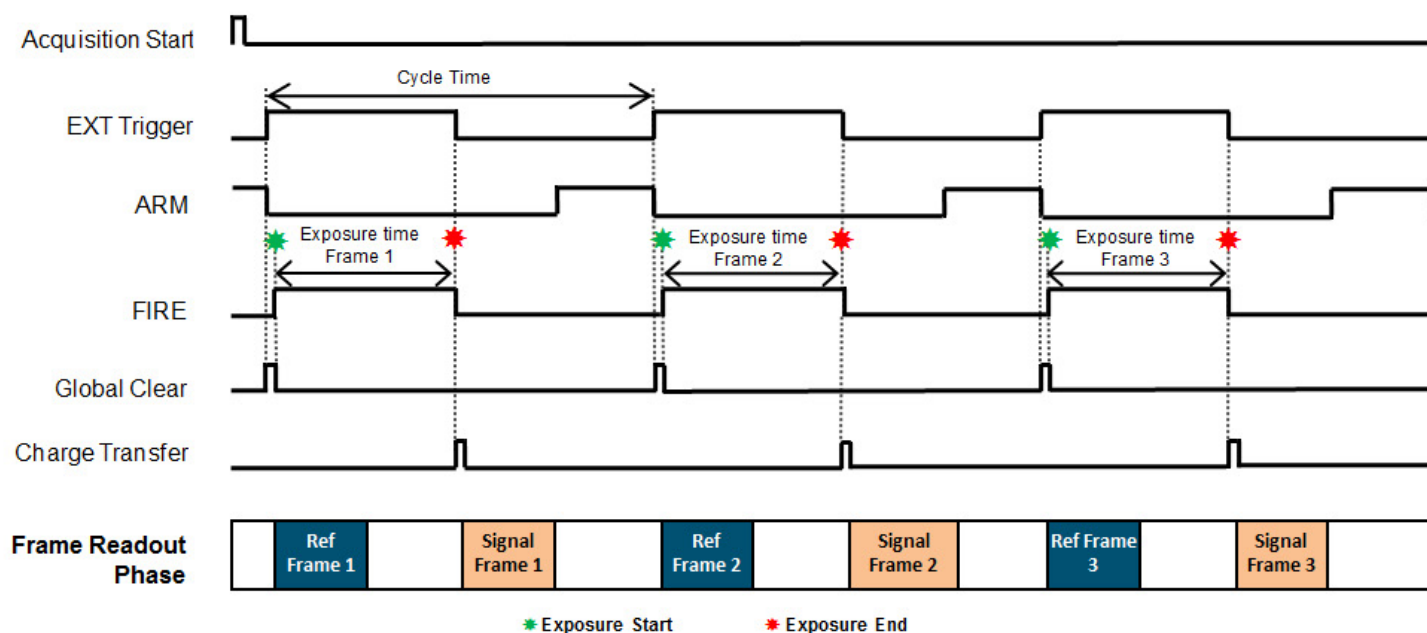

FIGURE 33: GLOBAL SHUTTER EXTERNAL EXPOSURE TRIGGERING (NON-OVERLAP MODE)

TABLE 31: GLOBAL SHUTTER EXTERNAL EXPOSURE TRIGGERING – NON-OVERLAP MODE TIMING PARAMETERS

PARAMETER	MINIMUM	MAXIMUM
Exposure (EXT Trig Pulse Width)	1 Frame + 3 Rows	2 <sup>31</sup> Rows
Cycle Time (EXT Trig Period)	EXT Trig Pulse Width + 1 Frame + 1 InterFrame + 6 Rows	-
Trigger Delay	1 Row	2 Rows
EXT Trig Pulse Width	1 Frame + 4 Rows	-

**NOTE:** In global shutter external exposure mode, taking exposures in darkness of 270ms or more will lead to increased noise. A reference frame is taken at the start of the exposure and the camera then idles until the end is signalled, which triggers the image readout. The increased noise is coming from the separation of the reference frame and the image frame. This is less prominent with deeper cooling.

### 2.7.3.5 GLOBAL SHUTTER EXTERNAL EXPOSURE TRIGGERING (OVERLAP MODE)

In overlap mode, every positive edge of an External trigger triggers a signal frame read out and starts a new exposure. The period of External trigger pulse defines both the exposure time and cycle time. Note that when an acquisition starts, the first positive edge of the trigger will initiate the first exposure but also output a frame that has an incorrect exposure which is therefore discarded internally. The next positive edge of the trigger will end the first exposure and start a new frame read out. From the figure below, it is can be seen that the minimum exposure time is approximately two frame read out periods. The first read out period is used to read out the “Signal” frame while the second is used to read out the “Reference” frame for the subsequent “Signal” frame.

If the period of the external trigger is less than the minimum period discussed above any positive edge occurring during the “Signal” and “Reference” frames will be ignored. The ARM signal indicates when positive going edges will be accepted.

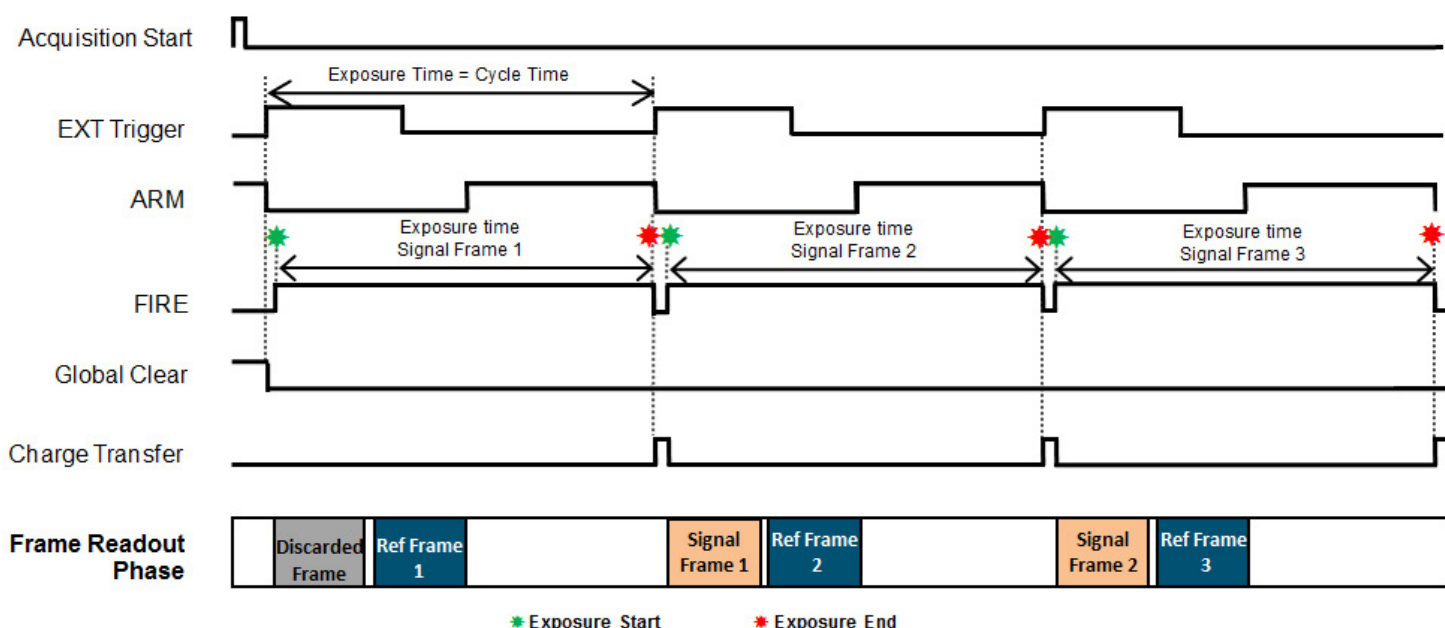

FIGURE 34: GLOBAL SHUTTER EXTERNAL EXPOSURE TRIGGERING (OVERLAP MODE)

TABLE 32: GLOBAL SHUTTER EXTERNAL EXPOSURE (OVERLAP MODE) TIMING PARAMETERS

PARAMETER	MINIMUM	MAXIMUM
Exposure (EXT Trig Period)	2 Frames + 2 InterFrames	-
Cycle Time ( EXT Trig Period)	2 Frames + 2 InterFrames	-
External Start Delay (1st Frame Only)	0	1 Row + Charge Transfer Time
External Start Delay (Frame #2... Frame #n)	Charge Transfer Time	Charge Transfer Time
EXT Trig Pulse Width	2 Sensor Speed Clock Cycles	-

**NOTE:** In global shutter external exposure mode, taking exposures in darkness of 270ms or more will lead to increased noise. A reference frame is taken at the start of the exposure and the camera then idles until the end is signalled, which triggers the image readout. The increased noise is coming from the separation of the reference frame and the image frame. This is less prominent with deeper cooling.

### 2.7.3.6 GLOBAL SHUTTER EXTERNAL START TRIGGERING

In this mode the camera will wait for a single external trigger event. Once this external trigger event is detected, the camera will progress as if the camera was in internal trigger mode. The ARM signal indicates to the user when the camera is ready to detect an External Start Trigger. The diagram below shows the External Start used in an Internal Trigger Non-Overlap Mode.

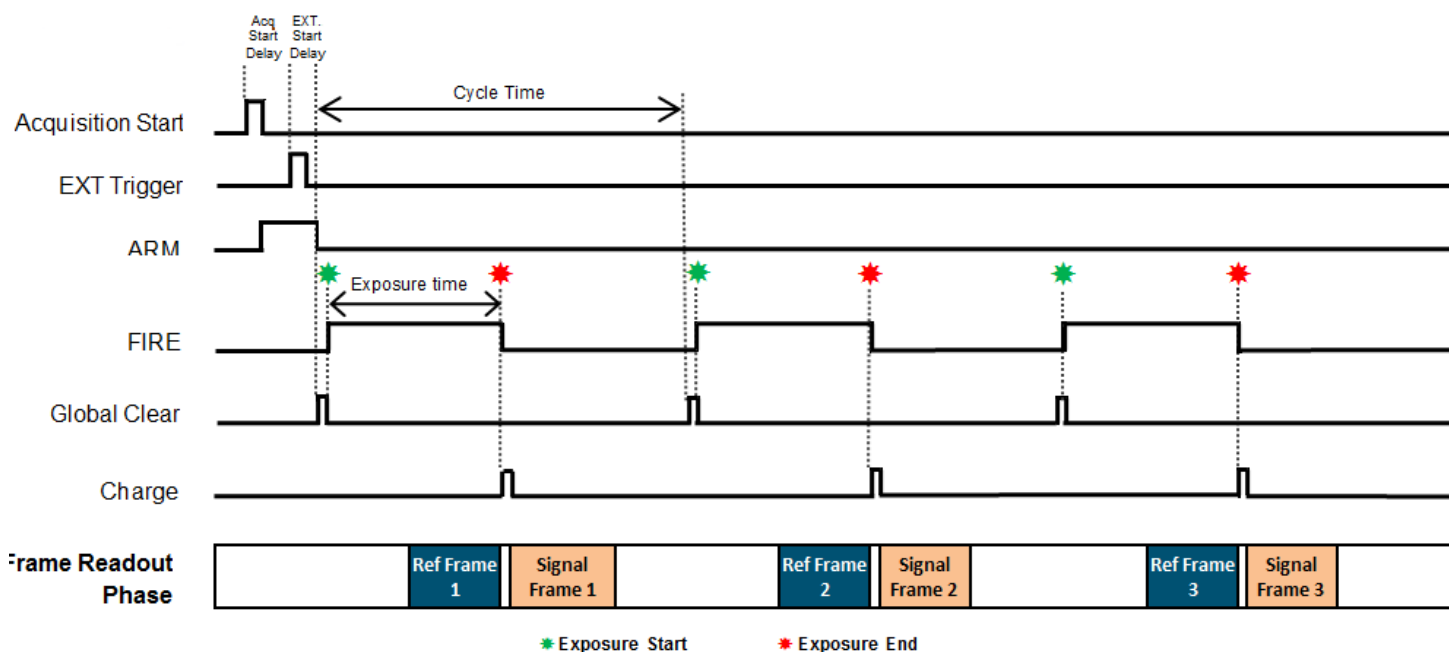

FIGURE 35: GLOBAL SHUTTER EXTERNAL START TRIGGERING

TABLE 33: GLOBAL SHUTTER EXTERNAL START TRIGGERING TIMING PARAMETERS (OVERLAP OFF)

	PARAMETER	MINIMUM	MAXIMUM
Short Exposure Mode	Exposure	1 Row	1 Frame + 3 Rows
	External Start Delay	0	1 Frame
Long Exposure Mode	Exposure	1 Frame + 4 Rows	$2^{31}$ Rows
	External start Delay	1 Row	2 Rows
	EXT Trig Pulse Width	2 Sensor Clock Speed Cycles	-

TABLE 34: GLOBAL SHUTTER EXTERNAL START TRIGGERING TIMING PARAMETERS (OVERLAP ON)

PARAMETER	MINIMUM	MAXIMUM
Exposure	1 Frame + 1 InterFrame + 1 Row	$2^{31}$ Rows
External Start Delay	1 Row	2 Rows
EXT Trigger Pulse Width	2 Sensor Clock Speed Cycles	-



### 2.7.3.7 GLOBAL SHUTTER TRIGGERING CONSTRAINTS

Table 35 below shows a summary of constraints when operating in Global Shutter mode:

TABLE 35: GLOBAL SHUTTER MODE CONSTRAINTS SUMMARY

GLOBAL SHUTTER TRIGGERING MODES		EXPOSURE RANGE	MAX TRIGGER JITTER	MIN TRIGGER PULSE WIDTH	FAST EXPOSURE SWITCHING SUPPORTED
Internal (Non-overlap)	User settable exposure time and Cycle Time	Short Exp 1 Row to (1 Frame) + 3 Rows	1 Frame	-	✓
		Long Exp (1 Frame + 4 Rows) to $2^{31}$ Rows	1 Row	-	✓
Internal Overlap (Overlap On)	User settable exposure time	(1 Frame + 1 Row + 1 InterFrame) to $2^{31}$ Rows	1 Row		✓
External/Software (Non-overlap)	User settable exposure Time. Cycle Time controlled via period of external trigger pulse	(1 Frame + 4 Rows) to $2^{31}$ Rows	1 Row	2 Sensor Clocks	✓
External/Software (Overlap On)	User settable exposure time. Cycle Time controlled via software trigger function	(1 Frame + 1 InterFrame + 1 Row) to $2^{31}$ Rows	1 Row	2 Sensor Clocks	✓
External Exposure (Non-overlap)	Exposure Time controlled by width of external trigger pulse.	(1 Frame + 3 Rows) to $2^{31}$ Rows	1 Row	1 Frame + 3 Rows	✗
	Cycle Time controlled via period of external trigger pulse.				
External Exposure (Overlap On)	Exposure time controlled by period of +ve edge of external trigger pulses. Cycle Time is exposure time	(2 Frames + 2 InterFrames) to $2^{31}$ Rows	1 Row	2 Sensor Clocks	✗
External Start (Non-overlap)	User settable exposure time and Cycle Time but sequence initialized via external trigger pulse	Short Exp 1 Row to (1 Frame + 3 Rows)	1 Frame	2 Sensor Clocks	✓
		Long Exp (1 Frame + 4 Rows) to $2^{31}$ Rows	1 Row		✓
External Start (Overlap On)	User settable exposure time	(1 Frame + 1 InterFrame + 1 Row) to $2^{31}$ Rows	1 Row	2 Sensor Clocks	✓

#### NOTES:

1. Exposure Time granularity for all modes is sensor row based so the exposure time in the dialog will be always rounded up to the nearest row.
2. 1 Row is the time taken to perform a full row readout (2624 clock cycles), i.e. depends on readout rate.
3. 1 Frame is the image height of a sensor half, defined in Rows and determined by the ROI configured, e.g. full frame = 1080. This is the number of rows that is read out by each sensor half. The frame readout time for any ROI can be requested via SDK function. (Refer to SDK3 User Guide for details).
4. A short exposure is referred to an exposure that is less than a Frame Readout Time. (Depends on ROI selected).
5. A long exposure is referred to an exposure time that is greater than a Frame Readout Time. (Depends on ROI selected).
6. Image acquisition must be stopped to change between short and long exposures. Fast Exposure Switching can occur in the triggering modes shown above but the exposure time is then limited to the exposure range shown for each sequence.

## 2.8 ACQUISITION MODES

The following acquisition modes can be supported:

- Single Scan
- Kinetic Series
- Accumulate
- Run Till Abort

### NOTES:

The term 'User Frame', in this section refers to a single frame in Rolling Shutter mode and a reference/image frame pair in Global Shutter mode.

The term 'valid trigger' refers to a trigger that is applied when the camera is ready to accept it.

### 2.8.1 SINGLE SCAN

**Single Scan** refers to an acquisition in which only one user frame is transmitted from the camera.

A user frame is output from the sensor on receipt of a valid trigger of the selected type, stored in the on-camera memory, and then transmitted from the camera. Note that any subsequent triggers within the same acquisition are ignored.

### 2.8.2 KINETIC SERIES

**Kinetic Series** refers to an acquisition in which a finite number of user frames are transmitted from the camera. The number of frames in a Kinetic Series is defined by the user. One user frame is output from the sensor on receipt of each valid trigger of the selected type and is stored in the on-camera memory. Valid triggers continue to output user frames from the sensor until the defined number of user frames has been reached. Frames are read out of the on-camera memory and transmitted from the camera. Note that after the required number of valid triggers has been received, any subsequent triggers within the same acquisition are ignored.

The trigger rate can exceed the maximum rate that frames can be transmitted from the camera, with the understanding that the on-camera memory will tend to fill. In this case, care must be taken with the number of frames defined in the series such that the on-camera memory does not become full otherwise the acquisition will not be able to completed.

### 2.8.3 ACCUMULATE

**Accumulate** refers to an acquisition in which a number of frames in a series are accumulated together into a single image. This accumulation of user frames is performed off-camera. Either all the user frames in a series are accumulated to give a single accumulated image or a smaller number of user frames in the series are accumulated to give a series of accumulated images.

### 2.8.4 RUN TILL ABORT ACQUISITION

**Run Till Abort** refers to an acquisition in which an infinite number of user frames can be transmitted from the camera and the acquisition will continue to run until it is aborted.

One user frame will be output from the sensor on receipt of each valid trigger of the selected type and is stored in the on-camera memory. All valid triggers will output another user frame from the sensor. Frames are read out of the on-camera memory and transmitted from the camera.

The trigger rate must not exceed the maximum rate that frames can be transmitted from the camera, otherwise the on-camera memory will fill up and the acquisition sequence will be aborted.

### 2.8.5 LIVE MODE

**Live Mode** refers to a version of Run Till Abort in which each user frame is the latest frame output by the sensor and with the minimum amount of latency through the camera as is possible.

Live mode requires the use of SW Trigger. In order to ensure that frames are buffered in the on-camera memory for the shortest possible time, the next SW trigger should not be sent until the frame has been transmitted from the camera.

**NOTE: This ensures that the on-camera memory only stores a single frame at a time and no additional latency builds up.**

**NOTE: The frame rate achievable in Live Mode is dependent on the performance of the system that the camera is attached to.**

### 2.8.6 FAST EXPOSURE SWITCH

During an acquisition the user can change the exposure time, within allowable limits. Once a new exposure value has been written, it will be applied to the next user frame after the current frame exposure has completed. The exposure time can be changed any number of times before the acquisition finishes

### 2.8.7 FRAME RATE CONTROL

If Internal Trigger is being used, the camera will trigger the sensor at the fastest possible rate by default. The user can reduce this trigger rate by defining a frame rate that is less than the maximum possible rate. Frame rate must be set before the acquisition starts.

## SECTION 3: INSTALLATION

### 3.1 SAFETY CONSIDERATIONS

- Prior to commencing installation, please refer to the Specifications in **Section 1.4** to ensure all requirements have been met
- As part of the safety features of the Neo 5.5, the product is designed to have a protective earth connected via the earth pin on the mains plug of the unit. It is important to ensure that this is connected to the buildings protective earth system
- The equipment should be positioned so that the mains supply plug/cord can be easily accessed for disconnection

### 3.2 MOUNTING THE CAMERA

To prevent damage to the Neo 5.5, other equipment and/or personnel the camera must be securely mounted before use. This can be using either one of the following points:

- The C-Mount or F-mount on the front face of the camera
- The ¼ -20 UNC threaded holes located on each side of the unit (please refer to **Section Appendix A**).

**NOTE: The black grommets need to be removed to access these mounting holes. Insert the black grommets when the mounting points are not used.**

### 3.3 MINIMUM COMPUTER REQUIREMENTS

The minimum computer requirements for the Neo 5.5 are as follows:

- **CPU:** 2.4 GHz Quad Core + 4 GB RAM (1600MHz DDR3)
- **Hard Drive:** Minimum 250 MB/sec continuous write for Spooling
- **PCIe Card:** PCIe x4 slot for Frame Grabber card
- **Operating System:** Windows (7, 8, 8.1, 10 or 11) or Linux
- **Misc:** USB 2.0 (for future firmware upgrades) Intel 82801 (or equivalent) I/O controller hub to provide interface for USB 2.0

Please also refer to Technical Note 'sCMOS Data Flow Considerations and PC Recommendations' (available to download at [andor.com](http://andor.com)).

### 3.4 INSTALLING SOLIS AND CAMERA LINK DRIVERS

**NOTE: You must have administrator access on your PC to perform this installation.**

1. It is recommended that the installation is run before installing the hardware
2. Run the "setup.exe" file on the CD or from download.
3. Confirm the version of Solis and click Next >.

4. Select the installation directory or accept the default when prompted by the installer.
5. The following window will be displayed:

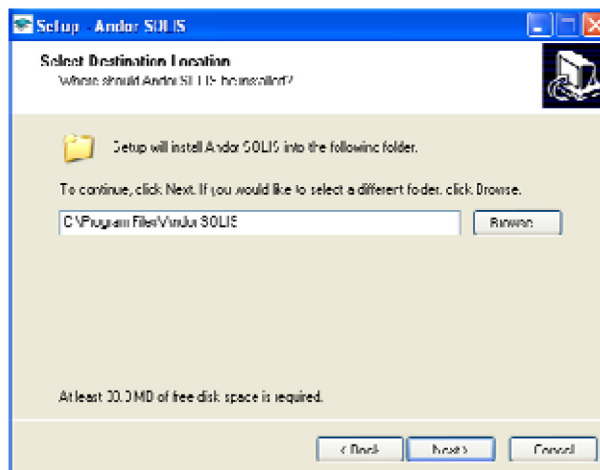

**FIGURE 36: SELECTING THE DESTINATION FOLDER**

6. Click on the drop down box and select Neo as shown:

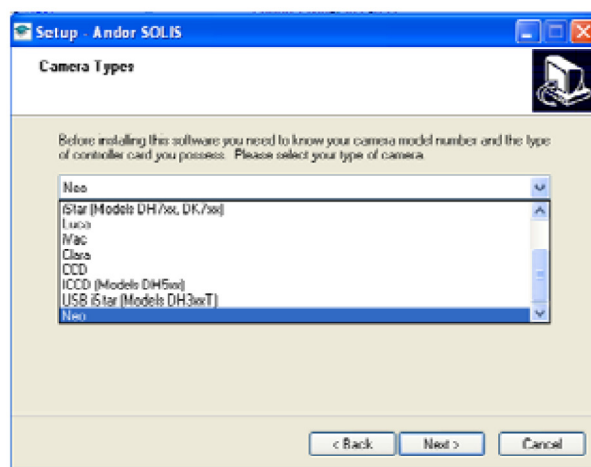

**FIGURE 37: SELECTING THE CAMERA TYPE**

7. Click the **Next >** button in the windows that follow and change the default options as required
8. On the final window click "Install" to perform the actual installation
9. During the installation a number of other windows will pop up as the Camera Link drivers are installed
10. Click on the **Finish** button when prompted
11. Shutdown the PC
12. Install the Camera Link controller card as described in **Section 3.5**

### 3.5 CAMERA LINK CONTROLLER CARD INSTALLATION

The Camera Link controller card is installed in the same manner as you would fit most other PCIe slot-in cards such as graphics cards.

**WARNING: Ensure that the computer is disconnected from the Mains power supply before opening the computer covers or access-panels. Observe all safety guidelines in the User Guide supplied with your computer.**

**WARNING: Observe precautions for handling electrostatic sensitive devices.**

**NOTE: Please consult the manual supplied with your computer to ensure correct installation of the controller card for your particular model. We recommend you perform the installation in a similar manner to the following:**

1. Power down the computer and any accessories
2. Unplug the computer and any accessories from the wall outlet(s)
3. Whilst observing appropriate static control procedures, unplug all cables from the rear of the computer
4. Unscrew any cover mounting screws on the computer and set them aside safely
5. Carefully remove the cover of the computer, e.g.:



**FIGURE 38: REMOVING THE COMPUTER COVER**

6. Locate the PCIe Expansion Slot (the one circled below is a x16 slot, but x4 or x8 slots can also be used):

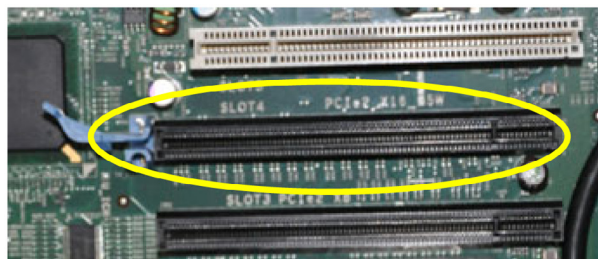

**FIGURE 39: IDENTIFYING THE PCIe EXPANSION SLOT**

7. After locating the slot, remove any metal filler bracket(s) that may be covering the opening for the slot at the back of the computer. Place any retaining screw(s) and/or clip(s) in a safe container, as you will need them later in the installation procedure
8. At this point, put on the ESD wrist strap supplied with your camera and attach the crocodile clip to a suitable metallic earth point on the PC e.g.:



**FIGURE 40: ATTACHING THE ESD WRIST STRAP**

**WARNING: The ESD strap must be worn at all times when handling the controller card**

- Remove the controller card carefully from its protective ESD packaging, e.g.:

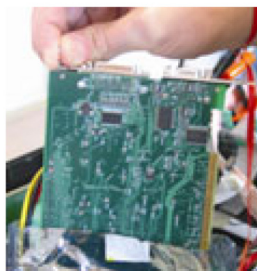

FIGURE 41: INSTALLING THE CONTROLLER CARD

- Firmly press the card connector into the chosen expansion slot and ensure it is securely locked in place

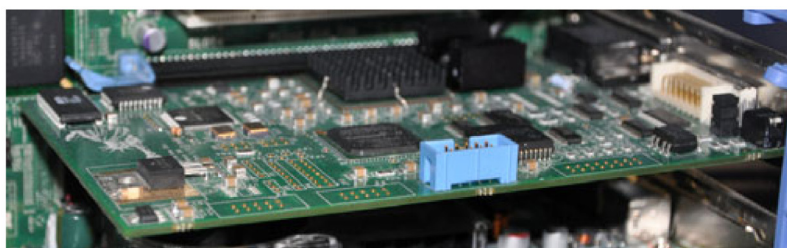

FIGURE 42: THE CONTROLLER CARD POSITIONED IN THE PCIe SLOT

- Ensure that the card's mounting bracket is flush with any other mounting brackets or filler brackets to either side of it and secure the controller card in place
- Replace the cover of the computer and secure it with the mounting screws if applicable
- Reconnect any accessories you were using previously

### 3.5.1 INSTALLING THE CAMERA LINK DRIVER

- Power on the PC
- If you are running Windows 7 or 8, the drivers will be installed automatically during start-up and you can skip the next step

**NOTE: NOTE: For Windows 7 and 8, users should deactivate sleep mode functions of the PC where possible (refer to Windows 7 or 8 help on your PC). Otherwise the computer would enter sleep mode. This would stop the software connecting to the camera and a reboot would be required.**

- If you are running Windows Vista you may be asked to specify the directory containing the Bitflow drivers. These are located in 'C:\Bitflow SDK 5.60\PlugAndPlay'
- If you are running Windows XP, then the 'Found New Hardware Wizard' dialog will be displayed following the restart
  - Select 'No, not this time' to 'Can Windows connect to Windows Update to search for software' and click on 'Next'
  - Select 'Install the software automatically' option and click on **Install**
  - The Camera Link drivers will now be installed

### 3.6 CHECKING & SETTING BIOS OPTIONS (FOR PCs NOT SUPPLIED BY ANDOR)

Enter the BIOS menu when starting PC. For Dell workstations, press F12 at start-up and select System Setup in the One Time Boot Menu. For Dell workstations 3 options in the Performance menu of the BIOS need to be checked/set:

- C-States Control – Disable C-States
- Intel Speed-step – Disable Speed-step
- Memory Node Interleaving – Set from NUMA to SMP. Note: This option is only available on larger workstations with 2 physical processors and may have a different name- ensure that NUMA is disabled.

### 3.7 COOLANT HOSE CONNECTION AND DISCONNECTION

#### WARNINGS:



Before attempting to insert or remove the Coolant hose connections, ensure that all coolant has been drained from the hoses and integral coolant channel within the camera head.

Care must be taken to avoid permanent damage to the camera system resulting from either leakage of coolant during connection / removal of hoses or spillage of any residual coolant contained within the camera head once the hoses have been removed. Never use damaged, split or worn hoses.

#### 3.7.1 CONNECTING THE COOLANT HOSES

1. Press the hose connector into the connection on the camera head and ensure it clicks into place, and repeat for the second hose as shown below:



**FIGURE 43: CONNECTING THE HOSE FITTINGS TO THE CAMERA COOLANT CONNECTORS**

2. Confirm the hoses are connected securely by applying pressure on the top front of the camera body and pulling backwards on the hoses as shown below:



**FIGURE 44: TESTING COOLANT HOSES ARE SECURELY CONNECTED**

3. The coolant hoses are now connected to the Neo 5.5 Camera.

#### 3.7.2 DISCONNECTING THE COOLANT HOSES

1. Press the latch on the camera hose connection away from the hose.
2. Hold the latch in and pull the hose backwards, as shown below.



**FIGURE 45: PRESSING THE LATCH ON THE CONNECTION TO RELEASE THE COOLANT HOSE**

3. The hose should release from the camera connection with little resistance.

**NOTE:** If the hose does not release, ensure that the latch on the camera connection is pressed in fully.



## SECTION 4: OPERATION

### 4.1 CONNECTING THE CAMERA

After you have successfully installed all software and drivers, connect the Neo 5.5 in the following sequence:

1. Power up the PC
2. Connect the power supply to the Power connection point on the rear of the camera
3. Connect the camera link cable between the CL1 connector labelled CL1 CAM on the rear of the unit and the port on the frame grabber card labelled CL1 PC.
4. If required connect the I/O expander cable to the 26-way I/O connector
5. Press the Power On/Off switch at the rear of the unit
6. Start the software

**NOTE: A USB connection is available for firmware upgrade only. If required, prior to power-up, connect the USB cable between the USB 2.0 connection point at the top-rear of the camera and any available USB 2.0 port on the PC. Remove the USB cable when not in use.**

### 4.2 COOLING

#### 4.2.1 PREVENTION OF CAMERA OVERHEATING

Care should be taken to ensure that the camera does not overheat, as this may lead to system failure. Overheating may occur if either of the following situations arises:

- The air vents on the sides of the camera are accidentally blocked
- The ambient air temperature is more than 40°C

To protect the camera from overheating, a thermal cut-out switch is linked to the heat sink. If the temperature of the heat sink rises above predefined limit then the current supply to the cooler will cut out and a buzzer will sound.

##### 4.2.1.1 OVERHEAT ALARM RESET

1. Ensure the reason for the overheating is corrected e.g. make sure the air vents are not blocked and ambient temperature is below 40°C.
2. Exit the software
3. Switch off the camera
4. Let the system cool
5. Restart the camera and software once the system has cooled down.

**Please refer to Section 4.2.2 for further information on Cooling.**

### 4.2.2 TE COOLING

The Neo 5.5 detector is cooled using a thermoelectric (TE) cooler. TE coolers are small, electrically powered devices with no moving parts, making them reliable and convenient. A TE cooler is actually a heat pump, i.e. it achieves a temperature difference by transferring heat from its ‘cold side’ (the Neo-chip) to its ‘hot side’ (the built-in heat sink). Therefore the minimum absolute operating temperature of the Neo sensor depends on the temperature of the heat sink. Our vacuum design means that we can achieve a maximum temperature difference of over 60°C. The maximum temperature difference that a TE device can attain is dependent on the following factors:

- Heat load created by the Neo 5.5 sensor dependant on pixel readout speed
- Number of cooling stages of the TE cooler
- Operating current

Even with a fan a heat sink typically needs to be at least 10°C hotter than the air (room) temperature to transfer heat efficiently to the surrounding air. Therefore the minimum temperature that can be achieved will be dependent on the ambient room temperature. **Table 36** shows typical minimum detector temperatures when operating at the different readout speeds and ambient temperatures:

**TABLE 36: NEO 5.5 DETECTOR COOLING TEMPERATURES**

AMBIENT TEMPERATURE	MINIMUM DETECTOR TEMPERATURES	
	200 MHz	560 MHz
20°C air cooled	-38°C	-35°C
25°C air cooled	-35°C	-31°C
30°C air cooled	-30°C	-27°C
35°C air cooled	-27°C	-23°C
40°C air cooled	-23°C	-19°C
16°C water cooled	-46°C	-43°C

These are typical figures and will vary from unit to unit, refer to the camera specification sheet for guaranteed minimum temperature levels and always allow sufficient headroom when conducting experiment to allow for fluctuations in ambient temperature conditions.

When using water cooling the minimum sensor temperature is no longer dependant on the external ambient but rather the temperature of the cooled water. Typical figures achieved when cooling using 16°C water are shown above. When water cooling it is important to always select a water temperature above the dew point to prevent condensation damage to internal electronics.

Solis provides selectable detector temperature options as follows:

- -15°C
- -20°C
- -25°C
- -30°C
- -35°C
- -40°C

**NOTE: Cooler Off (detector temperature will be stabilized at +26°C)**

### 4.3 FAN SETTINGS

The vast majority of applications, including optical microscopy, can be used with the default highest fan speed, since the vibrations from the fan are minimal. However some applications can be extremely sensitive to even the smallest of vibrations (such as when combining an optical set-up with patch clamp electrophysiology, or atomic force microscopy) so it may be useful to either select a slower fan speed, or to temporarily turn the fan off altogether for the duration of the acquisition.

In fan off mode the duration that the Neo can operate will vary depending on the sensor temperature selected, the ambient temperature and the readout speed. During fan off mode the Neo's internal heat sink temperature will begin to rise, as heat is no longer being extracted by the fan. When the heat sink temperature reaches approximately 45°C the fan will be forced on, this prevents any potential damage to the internal electronics. Some examples of typical operation duration in fan off mode are shown in **Table 37**:

**TABLE 37: DURATION OF NEO 5.5 CAMERA OPERATION BEFORE FAN IS FORCED ON (AT AMBIENT TEMPERATURE OF 25°C)**

SENSOR READOUT SPEED (MHz)	SELECTED SENSOR TEMPERATURE (°C)	DURATION BEFORE FAN IS FORCED ON (MINUTES)
560	-15	9
560	-30	5
200	-15	18
200	-30	12

After an acquisition in fan off mode the fan should be turned on again to give the unit time to re-stabilize (dissipate built-up excess heat from the TE cooler) before the next acquisition. To maximize the length of time the unit can be run in fan off mode reduce the heat load on the system by:

- Reducing the sensor readout speed
- Increasing the sensor set temperature

For example:

- Heat load is at a minimum with a sensor readout speed of 200 MHz and sensor temperature of -15°C
- Heat load is at a maximum with a sensor readout speed of 560 MHz and sensor temperature of -40°C

**NOTE: When water cooling is used there is no need to use the fan for cooling, the fan can be switched off. Also the fan will be disabled if the Neo internal heat sink temperature drops below approximately 20°C as would be the case when water cooling using 16°C water for example.**

### 4.4 SOFTWARE SUPPORT

The following software applications include support for the Neo 5.5 camera, check with your software supplier for applications not listed below:

- Andor Solis
- Andor SDK3
- Andor iQ
- MetaMorph

Details of how to set up the camera using various 3rd party software can be found on My Andor at [MyAndor > Software > Drivers](#).

Please refer to the application Help for details on how to control any Neo specific functionality. Andor SDK3 documentation is provided in the **Andor Software Development Kit 3.pdf** file that comes with the installation package if this has been ordered as an option.

## SECTION 5: MAINTENANCE

**WARNING: THERE ARE NO USER-SERVICEABLE PARTS INSIDE THE CAMERA. DAMAGE CAUSED BY UNAUTHORIZED MAINTENANCE OR PROCEDURES WILL INVALIDATE THE WARRANTY.**

### 5.1 REGULAR CHECKS

- The condition of the product should be checked regularly, especially the integrity of the External Power Supply and the mains cable
- Do not use equipment that is damaged

### 5.2 ANNUAL ELECTRICAL SAFETY CHECKS

- It is advisable to check the integrity of the insulation and protective earth of the product on an annual basis, e.g. within the U.K., PAT testing
- Do not use equipment that is damaged

### 5.3 FUSE REPLACEMENT

In the U.K, Ireland and some other countries, the supplied mains cable has a BS 1363 (or Type G) plug that includes an integrated fuse. Only replace with same fuse type and rating. The specifications of a replacement fuse are as follows:

**Rated Current:** 5 A

**Rated Voltage:** 240 VAC

**Size:** ¼ × 1" (6.3 × 25.4 mm) cartridge

**Type:** BS 1362

### 5.4 COOLING HOSES AND CONNECTIONS

The user should routinely check all coolant hoses and connections for signs of leakage, damage or wear. All seals must be intact before powering on camera system and any worn / damaged items must be replaced immediately.

## SECTION 6: TROUBLESHOOTING

We have included some typical issues you may encounter when initially using the Neo 5.5 sCMOS.

If you are unable to rectify any of the problems shown in this section, please contact Andor Technical Support for further advice.

### 6.1 CAMERA BUZZER DOES NOT SOUND ON START-UP

1. The camera buzzer should be audible momentarily when the camera is switched on.
2. If this does not occur, ensure that power is connected to the camera and the On/Off switch is set to On

### 6.2 CAMERA IS NOT RECOGNIZED BY PC

1. Ensure the camera is switched on
2. Check the Camera Link cable is connected between the CL1 connector position and the PCIe card in the PC
3. Check that the frame grabber card and drivers have been correctly installed (see **Sections 3.4** and **3.5**)

### 6.3 BUZZER SOUNDS CONTINUOUSLY

This indicates that an “over temperature” condition has occurred within the camera. Follow the instructions below to rectify this situation:

1. Power the camera off and allow it to cool down
2. Ensure chiller pipes (if fitted) are correctly mounted and that liquid is flowing through them
3. Ensure fan vents are not obstructed
4. Check the camera is operating within the specified environmental conditions (see **Section 1.4**)

### 6.4 FAN NOT OPERATING AS EXPECTED

1. The fan is normally disabled if the camera heat-sink temperature is below 20°C
2. To protect the internal electronics, the fan defaults to full speed if the camera heat-sink temperature exceeds 50°C.

**NOTE: The fan will continue to run even if the user has switched it off via software, until the correct heat-sink temperature has been reached.**

### 6.5 CAMERA DOES NOT COOL TO THE REQUIRED TEMPERATURE

Check that the required temperature is consistent with the figures shown in **Table 36**.

**NOTE: Allow sufficient head room for ambient temperatures fluctuations and camera performance, as the figures stated are typical.**

## 6.6 PREVENTING CONDENSATION

**NEVER USE WATER THAT HAS BEEN CHILLED BELOW THE DEW POINT OF THE AMBIENT ENVIRONMENT TO COOL THE CAMERA- A DEW POINT GRAPH IS SHOWN IN APPENDIX B FOR REFERENCE.**

You may see condensation on the outside of the camera body if the cooling water is at too low a temperature or if the water flow is too high. The first signs of condensation will usually be visible around the connectors where the water tubes are attached. If this occurs carry out the following actions:

1. Switch off the system
2. Wipe the camera with a soft, dry cloth.

**NOTE: It is likely there will already be condensation on the cooling block and cooling fins inside the camera.**

3. Set the camera aside to dry for several hours before you attempt reuse.
4. Before reuse blow dry gas through the cooling slits on the side of the camera to remove any residual moisture.

Use warmer water or reduce the flow of water when you start using the device again.

**NOTE: This is not an issue when using a Re-circulator which eliminates the dew point problem.**

## 6.7 FIRE, AUX\_OUT AND ARM OUTPUTS NOT FUNCTIONING CORRECTLY

These are 5V TTL outputs which should not be used to drive low impedance loads. Please refer to the diagram in **Section 1.7** for suggested terminations.

## 6.8 EXTERNAL TRIGGER INPUT NOT FUNCTIONING CORRECTLY

This is a 5V TTL input which should be driven from a 5V TTL compatible source. Please refer to the diagram in **Section 1.7** for further details.

## APPENDIX A.1: MECHANICAL DRAWINGS (NEO WITH C-MOUNT)

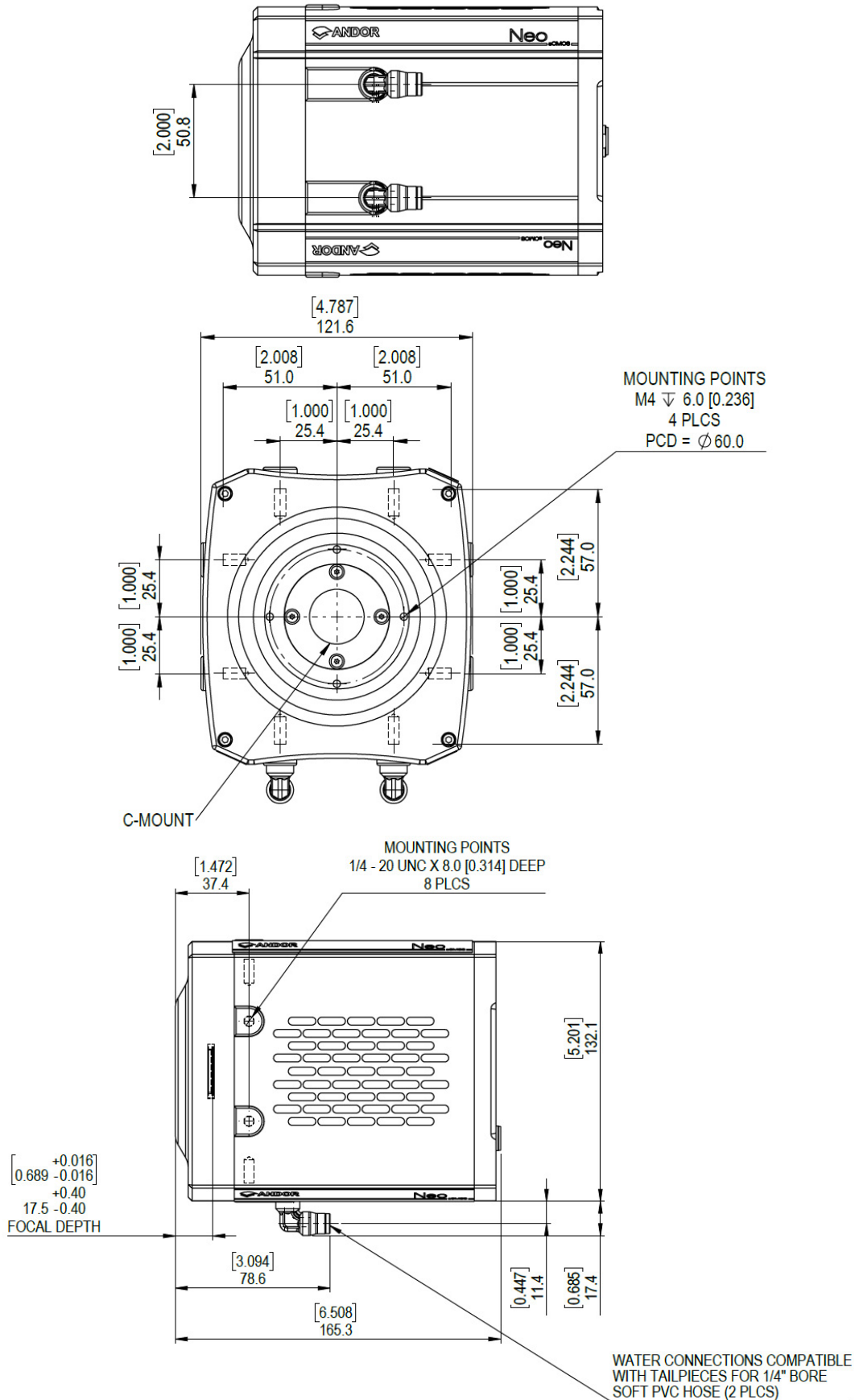



## APPENDIX A.2: MECHANICAL DRAWINGS (NEO WITH F-MOUNT)

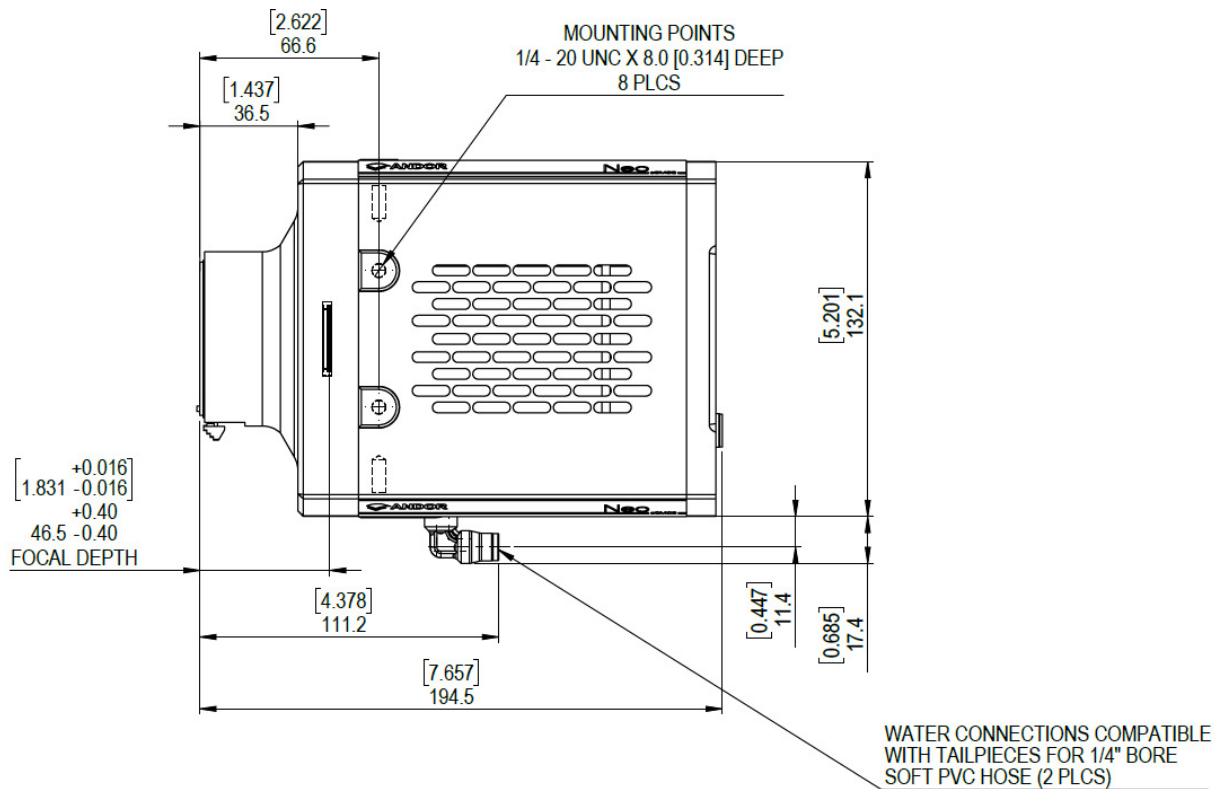
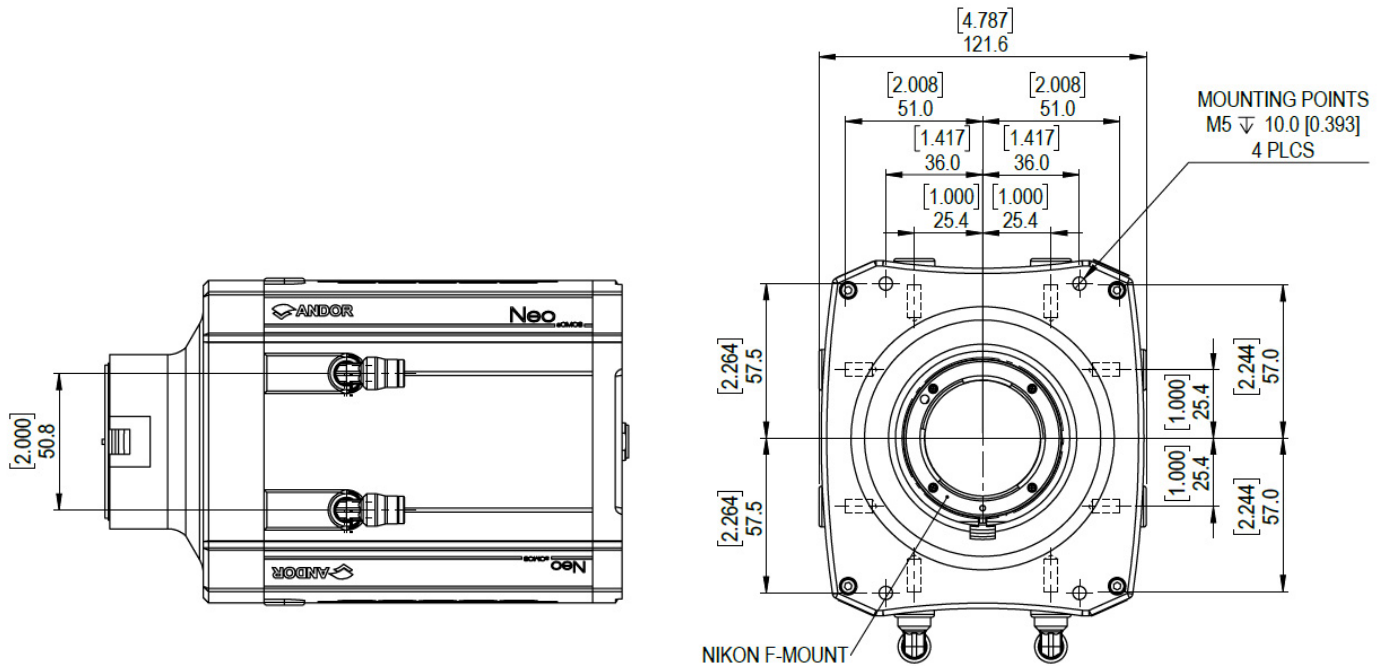

### APPENDIX B: DEW POINT GRAPH

The relationship between Relative Humidity and Dew Point at varying Ambient Temperature is shown below. This can be used to calculate the minimum temperature the cooling water should be set to.

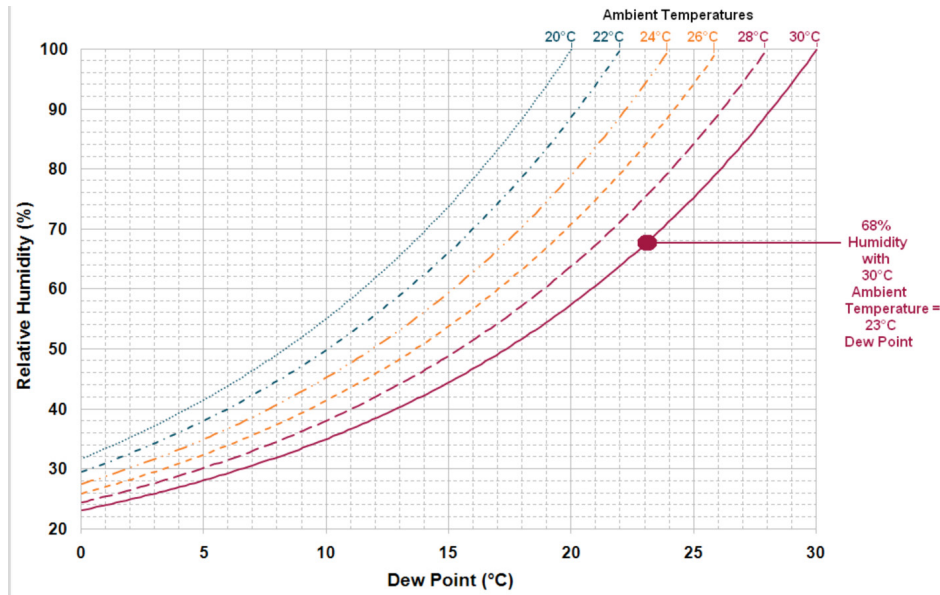

## APPENDIX C.1: WASTE ELECTRONIC AND ELECTRICAL EQUIPMENT REGULATIONS 2006 (WEEE)



Where appropriate, Andor has labelled its electronic products with the WEEE label (crossed out wheelie bin) to alert our customers that products bearing this label should not be disposed of in a landfill or with municipal waste. If you have purchased Andor-branded electrical or electronic products in the EU after August 13, 2005, and are intending to discard these products at the end of their useful life, Andor are happy to assist.

The cost for the collection, treatment, recycling, recovery and sound environmental disposal of these goods at the end of its useful life has not been included in the price. If you require help/assistance regarding the disposal of this equipment please refer to our website, or contact our sales team at which point instructions and a quotation can be provided.

A copy of the Company's WEEE Policy can be viewed at the Company website [www.andor.com](http://www.andor.com).

## APPENDIX C.2: TERMS AND CONDITIONS OF SALE AND WARRANTY INFORMATION

The terms and conditions of sale, including warranty conditions, will have been made available during the ordering process. The current version may be viewed at:

[http://www.andor.com/pdfs/literature/Andor\\_standard\\_warranty.pdf](http://www.andor.com/pdfs/literature/Andor_standard_warranty.pdf)