

Multi-Wavelength Imaging

Features and Benefits

- **Largest aperture**
Unique 22 mm aperture for large format sensors e.g. Neo and Zyla sCMOS
- **High quality achromatic lenses**
Image from 425 - 700 nm with minimal adjustment
- **Highest transmission**
> 96% @ 425 - 700 nm
- **Very low distortion**
< 0.5%
- **Bypass mode**
Dovetail mount for precise insertion, exchange and bypass of optical elements
- **Robust, compact and accurate**
Rigid structure provides optical and mechanical stability
- **Convenient user adjustment**
User-controls for focus adjustment and 2-axis cassette alignment are accessed via the front porch
- **C-mount and CSU versions**
Couple directly to filter wheels, microscopes, C-lenses and spinning disk confocal scanners
- **Various magnifications**
Match cameras to CSU aperture or control effective pixel size

Andor TuCam - High Performance, Two Camera Imaging Adapter

Andor's TuCam is a new generation two-camera adapter for macro or microscopic imaging applications. Available in C- or CSU-X-mount, TuCam features include large aperture, exceptional transmission, very low distortion and high precision alignment using kinematic cassettes.

TuCam can be configured for simultaneous imaging from two similar cameras or as a switch between camera models with different imaging capabilities.

A full range of beam splitting optics are available with custom-designed kinematic cassettes for precision alignment. These include wavelength and polarization splitters of the highest quality as well as a first surface mirror for switching between cameras.

A variety of camera tubes and lenses is available to provide magnifications of 1.0x, 1.2x, 1.5x and 2.0x independently for each arm of the adapter. A filter wheel can also be integrated at the input of TuCam to enable pre-filtering of the desired emission band.

Specifications Summary

Wavelength range	400 - 750 nm
Aperture size	22 mm
Transmission	> 96%

Application Guide

- ✓ Real time multi color imaging
- ✓ Co-localization
- ✓ Fluorescence Resonance Energy Transfer (FRET)
- ✓ Ratiometric imaging
- ✓ Super resolution
- ✓ Anisotropy imaging (inc. homo-FRET)
- ✓ Biplane / dual focal plane imaging
- ✓ Calcium flux / ion signalling e.g. Fura, Fluo-3 dyes
- ✓ Dual wavelength TIRF microscopy
- ✓ Dual wavelength real-time confocal microscopy
- ✓ Fluorescence In Situ Hybridization (FISH) imaging
- ✓ Simultaneous fluorescence /DIC imaging

Specifications^{*1}

Wavelength range	400 - 750 nm
Throughput (C-mount version) ^{*2}	> 96% (425-675 nm)
Throughput (CSU-X version) ^{*2}	> 93% (425 to 675 nm)
Chromatic aberration (focus shift) ^{*3}	< ± 0.2 mm (486 to 656 nm)
Distortion ^{*4}	< 0.5%
Differential distortion ^{*5}	< 0.5%
Maximum sensor format	22 mm diagonal
Field uniformity ^{*6}	> 90%
Chromatic magnification variation ^{*7}	< 25 μm (425 - 675 nm)
Camera field alignment error ^{*8}	< 32 μm

For detailed notes on performance figures annotated above, please refer to the last page of this specifications sheet.

Internal Optics

CSU-X version

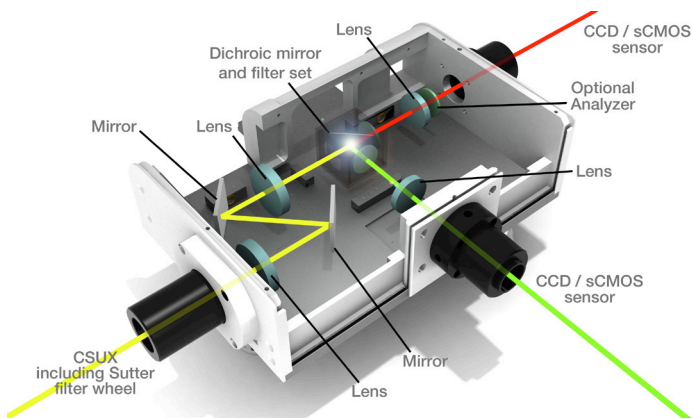

C-mount version

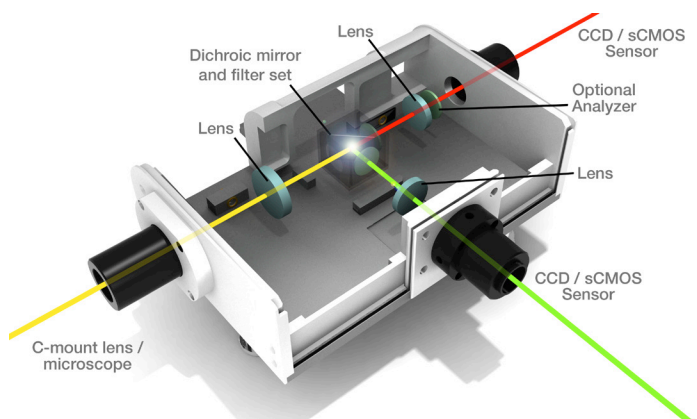

Dichroics and Polarizing Beams Splitters

Semrock®

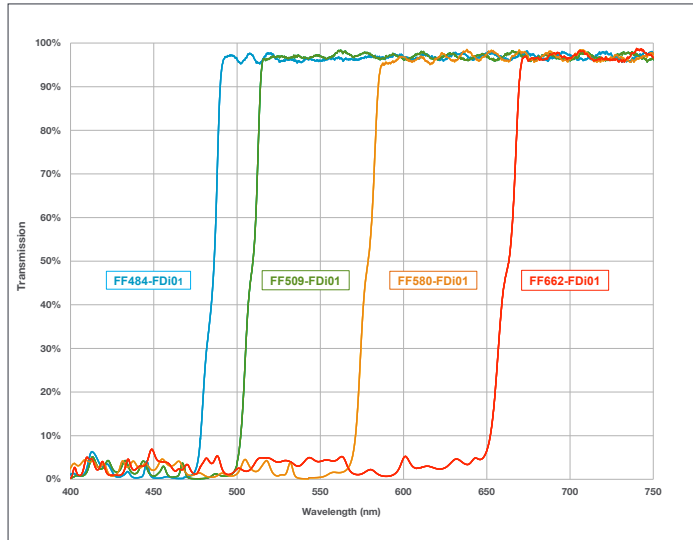

Moxtek®

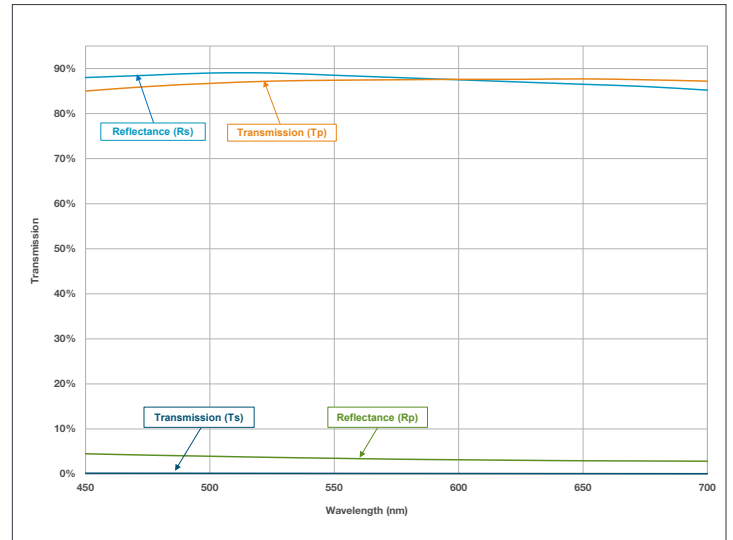

The graphs above show the transmission and reflectance curves for Semrock imaging dichroic beamsplitters and Moxtek optically flat polarizing beamsplitters. Both types of beamsplitter are optimized for use at a 45° angle of incidence.

Semrock's beamsplitters efficiently separate multicolored emission signals while maintaining excellent image fidelity. These dichroic beamsplitters are available for many popular fluorophore pairs. Their wide reflection and transmission bands and superb flatness allow for maximum light capture while minimizing image aberrations.

The Moxtek beam splitters deliver good transmission and excellent contrast. Optically flat polarizing beamsplitters are a specific product engineered for imaging applications. The quality of both the transmitted and reflected wavefront meet the exacting requirements of modern scientific instruments.

Transmission Curves

CSU-X

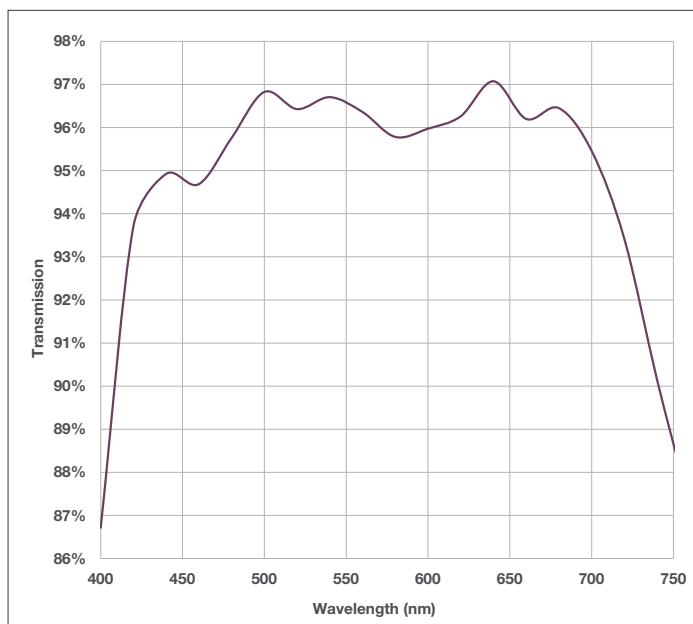

C-mount

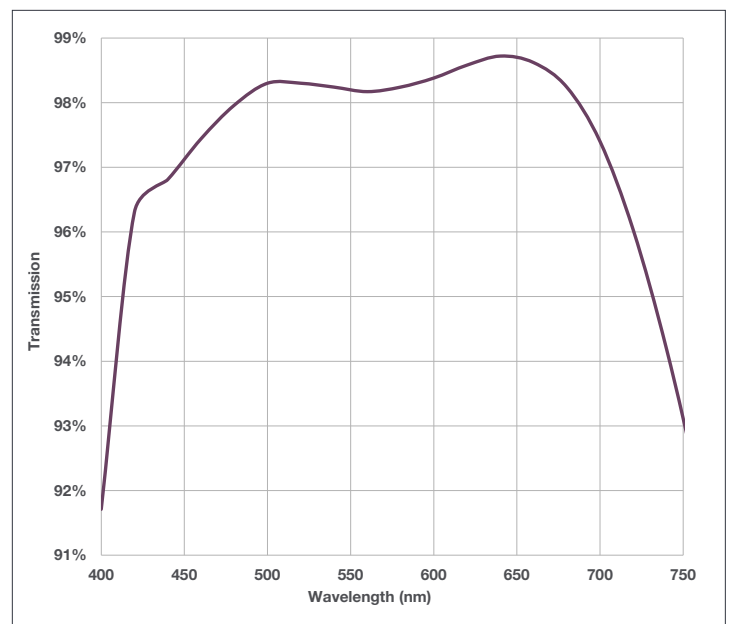

Andor's TuCam utilizes lenses with broadband anti-reflection coatings specifically chosen to maximise system throughput in the 400 to 750 nm wavelength band. The CSU-X version of TuCam also includes broadband dielectric mirrors that are optimized for this region. The transmission curve for the CSU-X version of the TuCam is shown on the left and for the C-mount version on the right. This is a typical performance for these instruments and may vary slightly between individual units. Beam splitter optics are not included, please refer to the Semrock and Moxtek graphs above for performance.

Creating The Optimum Product for You



Step 1. Choose the mounting type

Simply select from the 2 mounting options that best suit your needs:

	Description	Code
Mounting	For use with Revolution XD Yokogawa CSU-X fitted with customized external filter wheel	X-SUT
	Any C-mount device including microscope or lens	S-CMT

Step 2. Select the required magnification

Magnification	TR-DCIX-SUT		TR-DCIS-CMT (see note below)	
	Magnification required	Part Code	Magnification required	Part Code
	1x	TR-DCIX-100	1x	TR-DCIS-100
	1.2x	TR-DCIX-120	1.2x	TR-DCIS-120
	1.5x	TR-DCIX-150	1.5x	TR-DCIS-150
	2x	TR-DCIX-200	2x	TR-DCIS-200

TR-DCIX-SUT: it is important to choose the correct magnification for each camera port (magnification can be the same or different for each of the two ports). Refer to the 'Camera Matching' table on page 5.

TR-DCIS-CMT: 1x magnification is sufficient for all cameras. However, if a different effective pixel size is required, refer to the 'Camera Matching' table on page 5 for the appropriate magnification.

Step 3. Select the required Optical Cassettes

Please quote one or more of the following part numbers (we recommend one cassette per filter set to avoid risk of contamination when changing operating wavelength):

	Description	Part Code
Optical Cassettes	Blank cassette for mounting filter sets	TR-DCIS-CA1-00
	Cassette with mirror - to allow switching between camera ports	TR-DCIS-CA4-01

Step 4. Choose Wavelength or Polarization Filter Sets

	Short Description	Long Description	Part Code
Wavelength & Polarization Filter Sets	GFP/RFP	Semrock FF01-514/30, FF02-617/73, Dichroic FF580-FDi01	TR-EMFS-F01
	CFP/YFP	Semrock FF01-475/28, FF01-550/49, Dichroic FF509-FDi01	TR-EMFS-F02
	Polarizing filter set	Moxtek Wire Grid Polarizer BS PBF02C, 2 High Contrast cleanup filters PPL04C	TR-EMFS-F03
	CAMELEONS	Semrock FF01-483/32, FF01-542/27, Dichroic FF506-Di02	TR-EMFS-F05
	GFP/YFP	Semrock FF01-497/16, FF01-550/32, Dichroic FF509-FDi01	TR-EMFS-F07
	680/732 Filter Set	Semrock FF01-680/13, FF01-732/68, Dichroic FF700-Di01	TR-EMFS-F08

Continued on page 5...

Step 4. Choose Wavelength or Polarization Filter Sets (continued from page 4)

Wavelength
& Polarization
Filter Sets

Short Description	Long Description	Part Code
Cy3-Cy5	Semrock FF01-579/34, FF01-679/41, Dichroic FF640-FDi01	TR-EMFS-F09
Cy3/Cy5.5	Semrock FF01-579/34, FF01-692/40, Dichroic FF640-FDi01	TR-EMFS-F12
Fluo4/Fura Red	Semrock FF01-530/43, Chroma HQ615LP, Dichroic FF580-FDi01	TR-EMFS-F13
GFP/Cy5	Semrock FF01-525/45, Semrock FF01-680/42, Dichroic FF580-FDi01	TR-EMFS-F14
50/50 BS Mirror	Chroma 50/50 beamsplitter	TR-EMFS-F15
GFP/mCherry	Semrock FF02-525/40, FF01-640/40, Dichroic FF580-FDi01	TR-EMFS-F17
GFP/Cy5	Semrock FF01-534/42, FF01-655/40, Dichroic FF580-FDi01	TR-EMFS-F20
GFP/mCherry:wide	Semrock FF01-534/42, FF01-641/75, Dichroic FF580-FDi01	TR-EMFS-F21

Step 5. Select the required Accessories

The optical height of the system is 110 mm. We recommend that cameras and microscopes are raised using one of the following accessories:

Accessories

Description	Part Code
Mounting feet for iXon Ultra, iXon Life and Neo cameras	TR-IXON-MNT-110
Mounting feet for Zyla cameras	TR-ZYLA-MNT-110
CSUX 110 mm Opt Axis Mount Kit	CR-CSUX-MNT-110
Mounting feet for Olympus IX71/81	TR-OLIX-MNT-110
Mounting feet for Nikon TE-2000	TR-NKTE-MNT-110
Mounting feet for Nikon Eclipse Ti-E	TR-NKTI-MNT-110
Mounting feet for Zeiss Axiovert 200 and Zeiss Axio Observer	TR-ZSAV-MNT-110

The following accessory is also available to enable Nomarski DIC imaging and user alignment of new dichroics with the calibration slide:

Internal mounting for DIC polarizer	TR-DCIS-DIC-MNT
-------------------------------------	-----------------

Camera Matching

Andor Camera Type	Sensor Format	Pixel Size	Magnification Required to Fill Sensor: when fitted to CSUX or to alter effective pixel size (when attached to TR-DCIS-CMT)
Zyla sCMOS	2560 x 2160	6.5 µm	1x ^{*9}
Neo sCMOS	2560 x 2160	6.5 µm	1x ^{*9}
iXon Ultra/Life 897	512 x 512	16 µm	1.2x (13.3 µm effective pixel size) ^{*10}
iXon Ultra/Life 888	1024 x 1024	13 µm	2x (6.5 µm effective pixel size) ^{*10}

Note: We minimize chromatic aberrations in our systems, but other optics have their own limitations. Chromatic errors in the microscope objective are small, but scale by magnification at the detector. Consequently, we recommend software corrections for precision alignment.

Product Drawings

Dimensions in mm [inches]

CSU-X version

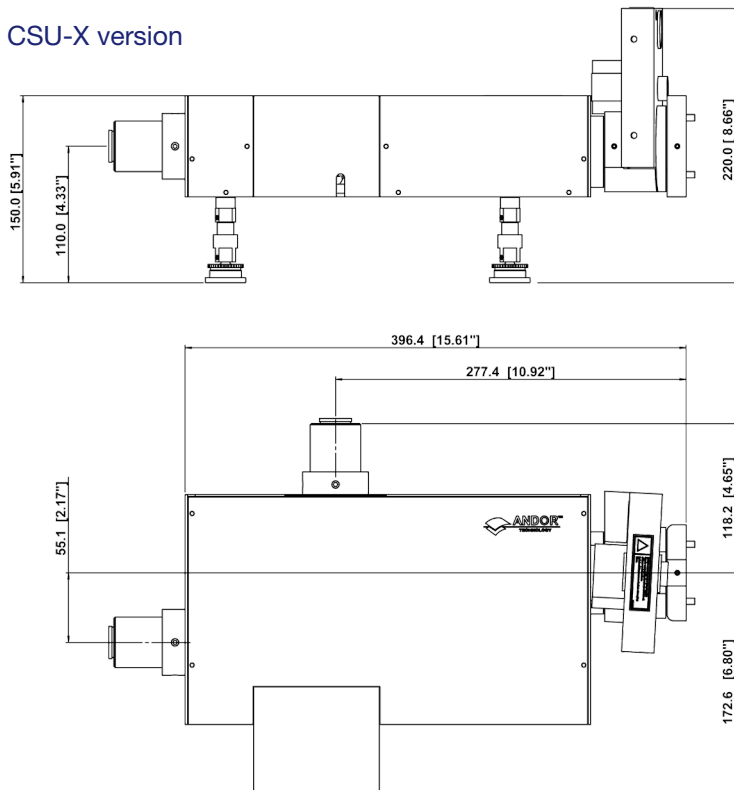

Weights:

Cassette = 0.35 Kg [12 oz]

Main unit = 5.5 Kg [12 lb 2 oz]

C-mount version

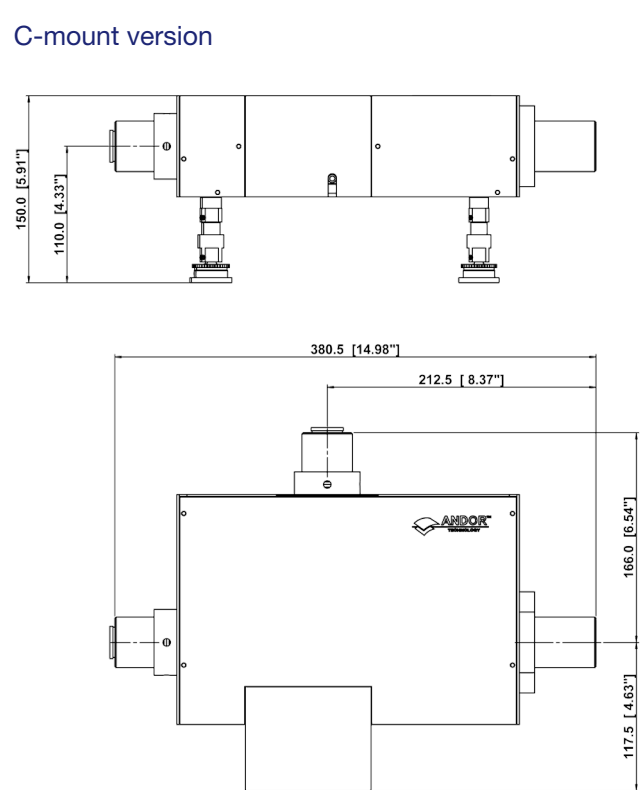

Weights:

Cassette = 0.35 Kg [12 oz]

Main unit = 4 Kg [8 lb 13 oz]

Recommended Microscopy Software For TuCam

The following software packages have been verified under simultaneous dual camera acquisition mode, as well as offering functionality to merge and analyze data from each channel.

Please see 'Application and Technical Notes' section of the Multi-Wavelength Imaging brochure for further details.





Order Today

Need more information? At Andor we are committed to finding the correct solution for you. With a dedicated team of technical advisors, we are able to offer you one-to-one guidance and technical support on all Andor products. For a full listing of our regional sales offices, please see: andor.com/contact

Our regional headquarters are:

Europe

Belfast, Northern Ireland
Phone +44 (28) 9023 7126
Fax +44 (28) 9031 0792

Japan

Tokyo
Phone +81 (3) 6732 8968
Fax +81 (3) 6732 8939

North America

Concord, MA, USA
Phone +1 (860) 290 9211
Fax +1 (860) 290 9566

China

Beijing
Phone +86 (10) 8271 9066
Fax +86 (10) 8271 9055

Items shipped with your system:

- 1x Grid slide
- 1x Target for alignment
- 1x Appropriate allen key set for installation
- 1x Quick installation and alignment guide
- 1x Individual system performance booklet

Footnotes: Specifications are subject to change without notice.

1. Specifications are based on the 1.2x CSU version of TuCam using a Semrock imaging-flat dichroic beamsplitter and 2 iXon₃ CCD cameras (512 x 512 format with 16 μm pixel size, 8.2 mm x 8.2 mm image area)
2. System throughput is obtained from the optical model of the system which considers the lens coatings, dielectric mirror performance, Fresnel effects, vignetting and internal transmittance
3. Chromatic focal shift is the shift in the back focal length for the wavelength range 486 to 656 nm. Focal shifts for wavelengths above and below these values may vary.
4. Distortion manifests itself as different parts of the object being reproduced with different magnifications in the image after passing through an optical system. Distortion is expressed as a percentage deviation of a point in the image from the same point in the object.
5. Differential distortion is the difference in the distortion level of identical points in the two imaging paths. This measure is dependent on the quality and setup of the optical system.
6. Field uniformity is a measure of the flatness of the intensity distribution whilst under uniform illumination.
7. Chromatic magnification (lateral color) is evident for off axis rays and is a consequence of the different wavelengths of light being refracted at differing angles as they traverse an optical system. Overlaying images taken at different wavelengths will highlight this effect as the different colors appear to have different magnifications. Careful selection of lens materials minimise this effect.
8. Alignment error is the maximum difference in the position of a particular point in one of the imaging paths to that in the other. The central quadrant of the image will have pixel alignment but due to optical affects the alignment error will increase towards the field edge.
9. When using an sCMOS camera, a sub-array of pixels matching the aperture, will be read.
10. Additional magnification alters image brightness. Use only if improving spatial resolution or field of view is crucial.



The Business of Science®

Operating and Storage Conditions

- Operating Temperature: 15°C to 30°C ambient
- Relative Humidity: < 70% (non-condensing)
- Storage Temperature: -25°C to 50°C

Semrock is a registered trademark of Semrock, Inc.
Moxtek is a registered trademark of MOXTEK Inc.

