

# Newton Hardware Guide

Version 1.5 rev 29 Jun 2022

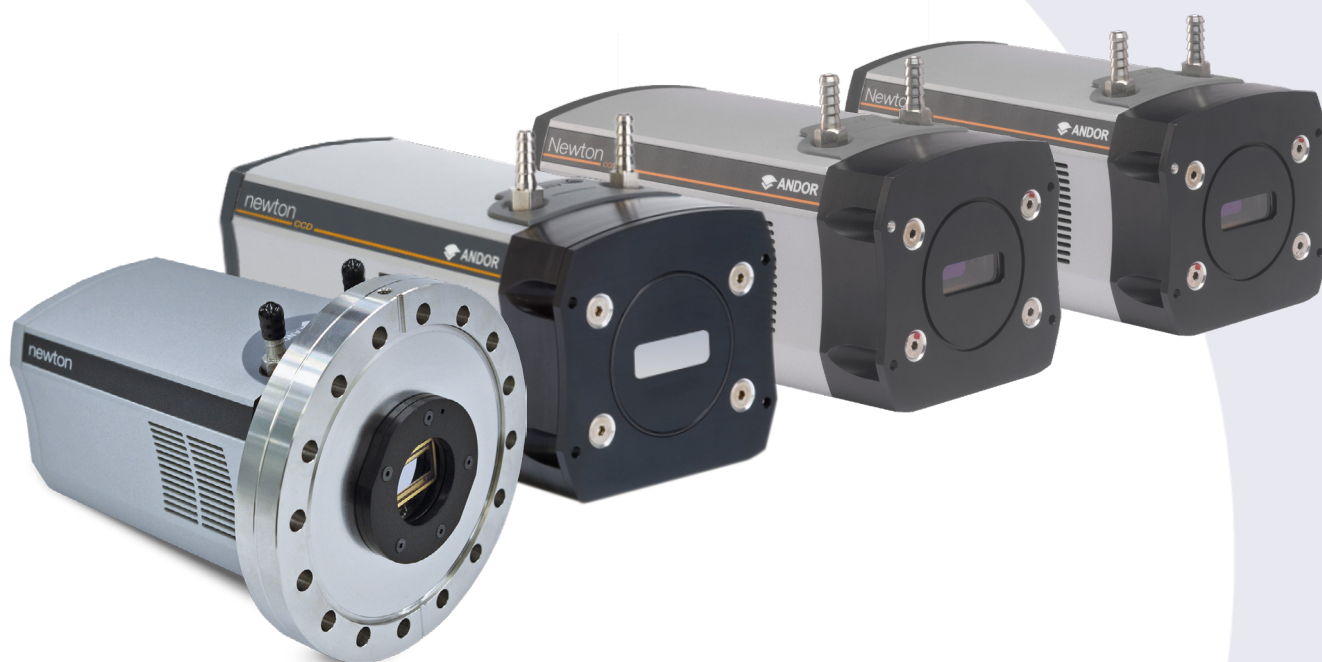

## Covering models:

- Newton CCD
- Newton EMCCD
- Newton SO
- Newton SY

<b>SECTION 1: INTRODUCTION.....</b>	<b>10</b>
1.1 TECHNICAL SUPPORT .....	11
1.2 DISCLAIMER .....	12
1.3 COPYRIGHT AND PROTECTIVE NOTICES.....	12
1.4 TRADEMARKS AND PATENT INFORMATION.....	12
1.5 SUPPLIED COMPONENTS .....	13
1.5.1 NEWTON MODEL OPTIONS.....	14
1.5.2 OPTIONAL ACCESSORIES .....	14
<b>SECTION 2: PRODUCT OVERVIEW.....</b>	<b>15</b>
2.1 EXTERNAL FEATURES OF THE NEWTON.....	15
2.2 REAR PANEL .....	16
2.3 POWER SUPPLY UNIT .....	17
2.4 POWER REQUIREMENTS .....	17
<b>SECTION 3: INSTALLATION .....</b>	<b>18</b>
3.1 TRANSPORT AND STORAGE INFORMATION .....	18
3.2 MOUNTING THE NEWTON USING THE MOUNTING FLANGE.....	18
3.3 ATTACHING TO MOUNTING POSTS.....	18
3.4 C-MOUNT .....	18
3.5 CONNECTING THE NEWTON TO THE PC.....	18
3.6 CONNECTING THE NEWTON TO THE POWER SUPPLY .....	19
3.7 CONNECTING A COOLING SYSTEM.....	19
3.7.1 IMPORTANT CONSIDERATIONS WHEN USING LIQUID COOLING SYSTEMS.....	19
3.7.2 COOLING HOSE CONNECTORS .....	19
3.8 COOLANT RECOMMENDATIONS .....	20
3.9 CONNECTING THE LIQUID COOLING SYSTEM .....	20
3.9.1 CONNECTING THE COOLANT HOSES.....	20
3.9.2 DISCONNECTING THE COOLANT HOSES.....	21

3.10	INSTALLING SOFTWARE AND USB DRIVERS .....	21
3.10.1	MINIMUM COMPUTER REQUIREMENTS .....	21
3.10.2	INSTALLING SOLIS SOFTWARE AND USB DRIVERS.....	21
3.10.3	NEW HARDWARE WIZARD.....	21
3.11	INSTALLING A USB 2.0 CARD (IF NOT PRESENT).....	22
<b>SECTION 4: OPERATION .....</b>		<b>23</b>
4.1	EMERGENCY MAINS DISCONNECTION .....	23
4.2	POWER-UP SEQUENCE.....	23
4.3	POWER-DOWN SEQUENCE.....	23
4.4	USING THE NEWTON .....	23
4.4.1	ADJUSTING THE COOLING FAN SPEED. ....	23
<b>SECTION 5: ADDITIONAL INFORMATION FOR SO AND SY MODELS.....</b>		<b>24</b>
5.1	NEWTON SO .....	24
5.1.1	BEST PRACTICE GUIDELINES.....	24
5.1.2	REMOVAL OF THE PROTECTIVE PLATE.....	24
5.1.3	MOUNTING THE CAMERA ON THE VACUUM CHAMBER FLANGE .....	26
5.2	NEWTON SY.....	27
5.2.1	BEST PRACTICE GUIDELINES.....	27
<b>SECTION 6: EMCCD MODEL INFORMATION .....</b>		<b>28</b>
6.1	EMCCD TECHNOLOGY .....	28
6.1.1	READOUT SEQUENCE OF AN EMCCD.....	28
6.1.2	IMPACT IONISATION .....	29
6.1.3	GAIN .....	30
6.1.3.1	GAIN & DYNAMIC RANGE .....	30
6.1.3.2	GAIN & NOISE.....	30
6.1.3.3	EM GAIN & TEMPERATURE.....	31

---

6.2	FURTHER COOLING INFORMATION FOR EMCCD MODELS .....	32
6.3	PHOTON COUNTING .....	33
6.4	OUTPUT AMPLIFIER SELECTION.....	34
<b>SECTION 7: MAINTENANCE.....</b>		<b>35</b>
7.1	REGULAR CHECKS .....	35
7.2	ANNUAL ELECTRICAL SAFETY CHECKS .....	35
7.3	GENERAL CLEANING & DECONTAMINATION INFORMATION.....	35
7.4	CLEANING THE CAMERA WINDOW .....	35
	7.4.1 TOOLS REQUIRED .....	36
	7.4.2 WINDOW CLEANING PROCEDURE .....	36
7.5	FUSE REPLACEMENT .....	36
7.6	COOLING HOSES AND CONNECTIONS.....	36
<b>SECTION 8: TROUBLESHOOTING .....</b>		<b>37</b>
8.1	PREVENTING CONDENSATION .....	37

---

<b>APPENDIX A: TECHNICAL SPECIFICATIONS.....</b>	<b>38</b>
<b>APPENDIX B: MECHANICAL DRAWINGS.....</b>	<b>39</b>
<b>APPENDIX C: DEWPOINT INFORMATION .....</b>	<b>41</b>
<b>APPENDIX D: REFERENCE INFORMATION.....</b>	<b>42</b>
<b>APPENDIX E: OTHER INFORMATION .....</b>	<b>43</b>
<b>APPENDIX F: NEWTON CHINA ROHS HAZARDOUS SUBSTANCES DECLARATION.....</b>	<b>44</b>

## REVISION HISTORY

Version	Released	Description
1.0	Nov 2006	Initial release
1.1	-	-
1.2	Dec 2007	-
1.3	15 Aug 2008	-
1.4	13 Oct 2017	Fully revised (all sections). Updated to include Newton model variations. Additional information added regarding cooling and power requirements. Solis information removed- this is available from Solis in-built help.
1.5	29 Jun 2022	Updated logo, updated addresses of US, Japan and China offices. Updated power connector information in section 2.3. Added China RoHS table to appendix. Removed links to MyAndor. Fixed all hyperlinks. Updated packing list. Updated health and safety information. Added REACH statement.

## UPDATES TO THIS MANUAL

Changes are periodically made to the product and these will be incorporated into new editions of the manual. Please check for new releases of the manual at [andor.oxinst.com/downloads/](http://andor.oxinst.com/downloads/). If you find an issue in this manual please contact your customer support representative (Section 1.1) with a description of the issue.



### PLEASE READ THIS INFORMATION FIRST BEFORE USING YOUR PRODUCT







1. If the equipment is used in a manner not specified by Andor, the protection provided by the equipment may be impaired.
2. Do not position this product so that it is difficult to operate the mains disconnecting device. See “4.1 Emergency Mains Disconnection” on page 23.
3. Before using the product, please follow and adhere to all warnings, and safety, manual handling, and operating instructions located either on the product, or in this manual.
4. Keep this manual in a safe place for future reference.
5. Users must be authorised and trained personnel only; otherwise, this may result in personal injury, and/or equipment damage and impaired system performance.
6. There are no user-serviceable parts inside the product and the enclosure must not be opened. Only authorised service personnel may service this equipment.
7. If using liquid cooling, ensure that the coolant supply is connected prior to powering the camera. Please also read all of the information relating to the use of coolant on page 20.
8. Protective earth is an integral part of the protection against electric shock in this product and is provided via the earth pin of the external power supply. Ensure that this is plugged into the building earth system via the mains socket. Do not tamper with any of the earthing measures.
9. Any External AC/DC Power Supply used with this product must meet the requirements specified on page 17.
10. No parts should be replaced by the customer, except for the mains cables or the fuse, which must be of the same type and rating as that supplied and as specified in “Electrical Power Specifications” on page 17 or “Fuse Replacement” on page 36, and certified in accordance with your region’s safety regulations.
11. Make sure all cables are located so that they will not be subject to damage, especially the mains cable.
12. While running an experiment, keep room temperature as stable as possible.
13. Performance of the system may be adversely affected by rapidly changing environmental conditions or operation outside of the operating conditions specified in “Appendix A: Technical Specifications”.
14. Ensure that adequate ventilation is provided as specified in “Appendix A: Technical Specifications”.
15. This product is designed to be used in an indoor environment. If the customer chooses to use this outside, then it is their responsibility to provide adequate protection. Andor assumes no liability for damage or obligation to repair under warranty relating to use outside of the environmental requirements specified in “Appendix A: Technical Specifications”.
16. Medical Diagnosis: This equipment has not been designed and manufactured for the medical diagnosis of patients.
17. Electromagnetic Compatibility – Caution: The version of the product using the PS-25 was designed for and tested using the IEC/EN 61326-1 EMC standard for Class A emissions and a Basic immunity environment. Class A means that it is not designed for a domestic or residential environment, and Basic immunity refers to the fact that it is not designed for a typical industrial environment. This equipment is not intended for use in residential environments and may not provide adequate protection to radio reception in such environments.

- 
18. Electromagnetic Compatibility: The version of the product using the PS-24 was designed for and tested using the IEC/EN 61326-1 EMC standard for Class B emissions and a Basic immunity environment. Class B means that it is designed for a domestic or residential environment, and Basic immunity refers to the fact that it is not designed for a typical industrial environment.
  19. Electromagnetic Compatibility: As required by IEC/EN 61326-1, we must inform you that electromagnetic emissions in excess of that required by that EMC standard for the emissions class of this product can in theory occur due to its connection to other equipment.
  20. This product can experience elevated noise levels when exposed to AM radiowave disturbances in the frequencies 152 – 154 MHz and 899 MHz, but this is allowed as permissible loss of performance under IEC 61326-1 and there have never been any reports of issues due to this.
  21. Electromagnetic Compatibility: This product has been designed and tested to perform successfully in a normal (basic) electromagnetic environment, e.g. a typical life science test laboratory, as per the EU EMC Directive. It is not designed to operate in a harsh electromagnetic environment, e.g. close to the following equipment: EMI/RFI generators, electrostatic field generators, electromagnetic or radioactive devices, plasma sources, arc welders, x-ray instruments, intense pulsed sources, or other similar sources of high energy fields whose emissions are not within the normal range expected under the EU EMC Directive.
  22. Ionising Radiation: Please note that this product is not designed to provide protection from ionising radiation. Any customer using this product in such an application should provide their own protection.
  23. This product is a precision scientific instrument containing fragile components. Always handle it with care.
  24. Do not wet or spill liquids on the product, and do not store or place liquids on the product.
  25. If spillage occurs on the product, switch off power immediately, and wipe off with a dry, lint-free cloth.
  26. If any ingress of liquids has occurred or is suspected, unplug the mains cables and do not use. Contact customer support.
  27. See “7.3 General Cleaning & Decontamination Information” on page 35.
  28. Do not expose the product to open flames.
  29. Do not allow objects to fall on the product.



## WARNING AND SAFETY LABELS

### LABEL SYMBOLS

	General Warning Symbol: See adjacent text on label.
	EU CE Mark by which we indicate that this product meets the requirements all the relevant EU Product Directives that require this mark, including the Low Voltage Directive for safety (as this product is manufactured in Northern Ireland, it does not require the UKCA Mark)
	EU WEEE (Waste Electrical and Electronic Equipment) Mark which indicates that this should not be disposed of in domestic waste but at a suitable recycling site
	China EPUP (Environmental Protection Use Period) Mark that indicates that this product is expected to last for 20 years approximately before ending-up in the waste and recycling system
	D.C. Voltage Symbol
	USB 2.0 Communications Connector

### UNPACKING INFORMATION

Carefully unpack the unit and retain the packaging materials to transport or return equipment if required:

- If the equipment appears damaged in any way, return it to sales outlet in its original packaging.
- No responsibility for damage arising from the use of non-approved packaging will be accepted.
- Ensure all items and accessories specified at the time of ordering and as detailed on the packing list are present: if any items are missing, please contact your sales representative.

---

## SECTION 1: INTRODUCTION

This manual provides an overview of the Andor Newton camera series. The Newton is available in different configurations including EMCCD sensor versions. The Newton platform is intended for spectroscopy applications such as multi-track spectroscopy, SERS, TERS or luminescence mapping. SO and SY versions are also available for high energy applications. This manual includes a description of the main features of the Newton, installation, routine operation and troubleshooting. It also provides a summary of some of the technical features of the Newton series. For further information on operation and control of the Newton refer to the relevant software guide e.g. Solis or SDK and to the andor website for further technical information to help you get the best from your camera.



Figure 1: The Newton

---

## 1.1 TECHNICAL SUPPORT

If you have any questions regarding the use of this equipment, please contact the representative\* from whom your system was purchased, or:

### Europe

Andor Technology Ltd.  
7 Millennium Way  
Springvale Business Park  
Belfast  
BT12 7AL  
Northern Ireland  
Tel. +44 (0) 28 9023 7126  
Fax. +44 (0) 28 9031 0792

### USA

Andor Technology  
300 Baker Avenue  
Suite # 150  
Concord  
MA 01742  
USA  
Tel. +1 (860) 290-9211  
Fax. +1 (860) 290-9566

### Asia-Pacific

Andor Technology (Japan)  
5F IS Building  
3-32-42 Higashi-Shinagawa  
Tokyo 140-0002  
Japan  
Tel: +81 (0) 3 6732 8968  
Fax: +81 (0) 3 6732 8939

### China

Andor Technology (China)  
Haitong Times Business Center,  
Building B2 West,  
No.11 West Third Ring North Road,  
Haidian District,  
Beijing, 100089, China  
Tel: +86 (0) 10 5884 7900  
Fax. +86 (0) 10 5884 7901

\* The latest contact details for your local representative can be found on the [Contact and Support](#) page of our website.

---

## 1.2 DISCLAIMER

THE INFORMATION CONTAINED HEREIN IS PROVIDED “AS IS” WITHOUT WARRANTY, CONDITION OR REPRESENTATION OF ANY KIND, EITHER EXPRESS, IMPLIED, STATUTORY OR OTHERWISE, INCLUDING BUT NOT LIMITED TO, ANY WARRANTY OF MERCHANTABILITY, NON-INFRINGEMENT OR FITNESS FOR A PARTICULAR PURPOSE.

IN NO EVENT SHALL ANDOR BE LIABLE FOR ANY LOSS OR DAMAGE, WHETHER DIRECT, INDIRECT, SPECIAL, INCIDENTAL, CONSEQUENTIAL OR OTHERWISE HOWSOEVER CAUSED WHETHER ARISING IN CONTRACT, TORT OR OTHERWISE, ARISING OUT OF OR IN CONNECTION WITH THE USE OF THE INFORMATION PROVIDED HEREIN.

## 1.3 COPYRIGHT AND PROTECTIVE NOTICES

The copyright in this document and the associated drawings are the property of Andor Technology Ltd. and all rights are reserved. This document and the associated drawings are issued on condition that they are not copied, reprinted or reproduced, nor their contents disclosed.

The publication of information in this documentation does not imply freedom from any patent or proprietary right of Andor Technology Ltd. or any third party.

## 1.4 TRADEMARKS AND PATENT INFORMATION





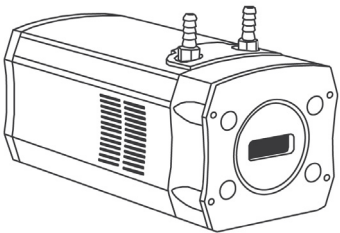

Andor and the Andor logo are trademarks of Andor Technology Ltd. Andor Technology Ltd. is an Oxford Instruments company. All other marks are property of their owners.

Newton Series Manufacturers Information

**Andor Technology Ltd., Belfast, BT12 7AL, UK.**

## 1.5 SUPPLIED COMPONENTS

Description		Quantity
	<p>Newton CCD (or EMCCD) Camera (model as ordered: refer to Specification sheet for full model information)</p>	1

	<p><b>Software</b> (Solis and SDK are ordered separately)</p>	-		<p>User guide <a href="http://andor.oxinst.com/downloads/">andor.oxinst.com/downloads/</a></p>	1
	<p>Performance Booklet</p>	1		<p>BNC-SMB Cable</p>	1
	<p>USB 2.0 Cable</p>	1		<p>PSU and country specific power cable</p>	1
	<p>Quick Start Guide</p>	1			

## 1.5.1 NEWTON MODEL OPTIONS

There are a number of models of Newton available. Refer to the specification sheet links for model specific information.

	Newton CCD	Newton EMCCD	Newton SO	Newton SY
Model Code	DU920P DU920P Bx-DD DU940P	DU970P DU971P	DO920P DO920P BR-DD DO940P	DY920P DY920P BR-DD Y940P
Active pixels	1024 x 255 (1024 x 256 for Bx-DD model) or 2048 x 512	1600 x 200 or 1600 x 400	1024 x 255 (1024 x 256 for Bx-DD model) or 2048 x 512	1024 x 255 (1024 x 256 for Bx-DD model) or 2048 x 512
Pixel size	26 or 13.5 µm	16 µm	26 or 13.5 µm	26 or 13.5 µm
Max Cooling	-100°C	-100°C	-100°C	-100°C
Air/Water cooling	•/•	•/•	•/•	•/•
Mounting Options (See mechanical drawing for details)	C-mount Front face 4x M4 [0.16] Mounting Posts (x3)	C-mount Front face 4x M4 [0.16] Mounting Posts (x3)	DN100CF / 6" CF / CF-152 Mounting Posts (x3)	C-mount Front face 4x M4 [0.16] Mounting Posts (x3))
Notes	-	EMCCD and conventional CCD operation	Open fronted "High Energy"	200 µm Beryllium foil window "High Energy"
Model Specific Information see:	<a href="#">Newton CCD</a>	<a href="#">Newton EMCCD</a>	<a href="#">Newton SO</a>	<a href="#">Newton SY</a>

## 1.5.2 OPTIONAL ACCESSORIES

A range of accessories is available (see table below). The Newton is intended only for use with accessories supplied and recommended by Andor. Please contact your local Andor representative if further information is required.

Description	Order Code	CCD	EMCCD	SO	SY
C-mount lens adaptor	LM-C	•	•	-	-
F-mount lens adaptor	LM-NIKON-F	•	•	-	-
Nikon F-mount lens adaptor with shutter	LMS-NIKON-F-NS25B	•	•	-	-
Shutter Driver for NS25B Bistable Shutter (not needed for Shamrock spectrographs)	ACC-SD-VDM1000	•	•	-	-
Bistable Shutter, Standalone (not needed for Shamrock spectrographs)	ACC-SHT-NS25B	•	•	-	-
USB Extender: Icron USB 2.0 Ranger 2201 (100 m) - EU/UK/US	ACC-USBX-EU ACC-USBX-UK ACC-USBX-US	•	•	•	•
Re-circulator for enhanced cooling performance	XW-RECR	•	•	•	•
Oasis 160 Ultra compact chiller unit	ACC-XW-CHIL-160	•	•	•	•
6 mm tubing option for ACC-XW-CHIL-160	ACC-6MM-TUBING-2xxxxM	•	•	•	•
Copper gasket for DN100CF / 6" CF open-front camera knife-edge vacuum seal	ACC-FLG-SO-GSKT-CU	-	-	•	-
SO-SY adapter for Newton CCD SO, Ø45.5 mm filter	FLG-SO-SY-CONVERT-45	-	-	•	-
Beryllium filter, Ø45.5 mm, 250 µm thick	ACC-OPT-02839	-	-	•	-

• compatible, - not applicable

## SECTION 2: PRODUCT OVERVIEW

This section provides an overview of the external features and the power and signal connections of the Newton. The CCD model is outlined- refer to model specific information as described, and Section 5 for SO and SY models.

### 2.1 EXTERNAL FEATURES OF THE NEWTON



Figure 2: Newton CCD

#### Mounting Flange

The mounting flange has 4 off mounting holes to clear M4 x 5 deep (see Appendix B).

#### Sensor

The Newton features high resolution CCD or EMCCD sensors with coatings depending on the model. Andor's unique UltraVac™ vacuum technology has also been applied to the Newton. UltraVac provides a permanent hermetically sealed enclosure for maximum QE and cooling performance over many years operation.

#### Camera Window

The Newton features a Single AR coated UV grade silica window for optimum transmission. (SY model features a Beryllium window). For more information on camera windows please see [andor.oxinst.com/learning/view/article/camera-windows](https://andor.oxinst.com/learning/view/article/camera-windows).

#### Mounting Post Locations

There are three holes for the 1/4"-20 UNC tapped 0.4" deep mounting posts with 1" spacing located on the underside of the camera (not applicable to SO model).

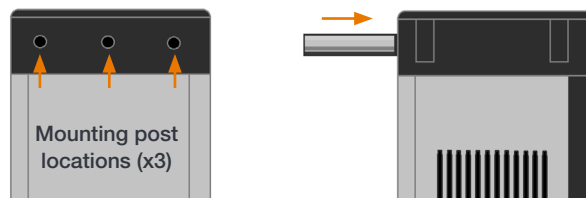

## 2.2 REAR PANEL

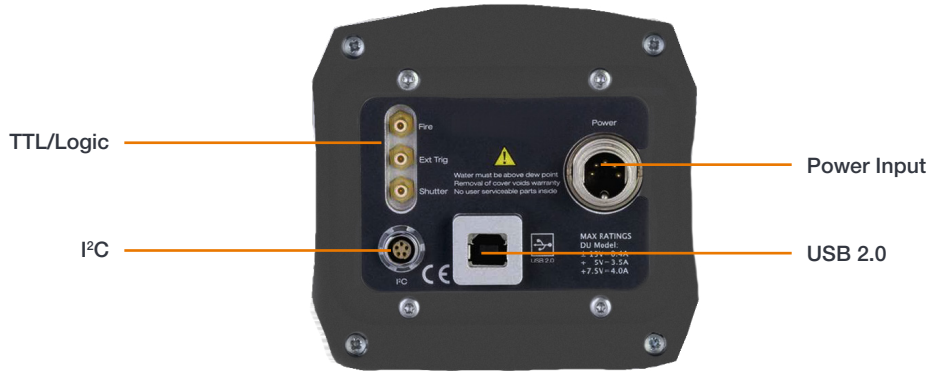

Figure 3: Rear Panel

### USB 2.0

Connects the Newton to the control PC via a USB 2.0 connection.

### TTL / Logic

The TTL/Logic connection permit connection to other devices for synchronisation and control of fire, trigger and shutter operations. Connector type: SMA, provided with SMA - BNC cable Fire (Output), External Trigger (Input), Shutter (Output). The SMB outputs (Fire & Shutter) are CMOS compatible & Series terminated at source (i.e. in the camera head) for 50Ω cable. NOTE: The termination at the customer end should be high impedance (not 50Ω) as an incorrect impedance match could cause errors with timing and triggering. The SMB Ext Trig input is TTL level & CMOS compatible and has 470Ω impedance.

### I²C

The I²C provides a connection option via the I²C interface. Compatible with Fischer type SC102A054-130 connector. (1)Shutter (TTL), (2) I²C Clock, (3) I²C Data, (4) +5 Vdc, (5) Ground.

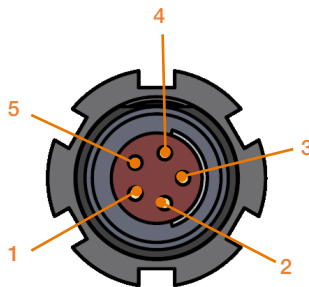

### Power

Power input connection for connection to the PSU. Refer to Section 2.3.

### Notes:

Minimum cable clearance required at rear of camera 90 mm.

Liquid cooling connections provide the facility for connection to re-circulator or other water/liquid cooling system. Refer to Section 3.7.



## 2.3 POWER SUPPLY UNIT

The standard PS-24 PSU is fitted with an IEC connector for the electrical supply input.

The connection to the Newton is made via a 5-pin DIN socket:

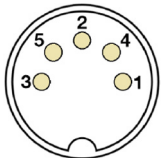
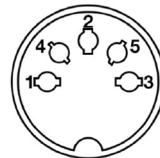
Pin	PS-24	PS-25		
1	+5V DC 5A max.	+5V DC 3.5A		
2	N/C	7.5V DC 4A		
3	Common	Common		
4	+15V DC 2A max.	+15V DC 100mA		
5	-15V DC 0.8A max.	-15V DC 100mA		
Shell	GND	GND		
			Camera Male Socket	Power Supply Female Plug

The optional PS-25 PSU can be used to achieve maximum cooling and has 2x settings, STANDARD COOLING or DEEP COOLING. The connection to the Newton is also made via a 5-pin DIN socket. The connectors are DIN 41524/ IEC 60130-9 5-pin 180° (a.k.a. 5-pin at 45° pitch) M16, IP67, shielded, straight type. The male sockets are Binder 09-0119-90-05 and the female plugs can be Binder 99-2018-02-05, Lumberg KV-50-8 or Amphenol T3361010.

## 2.4 POWER REQUIREMENTS

- Ensure that the power connector for the Newton camera is inserted securely. The connector is keyed to aid correct orientation.
- If users use any other power supply they do so at their own risk.

---

## SECTION 3: INSTALLATION

### WARNINGS:

- PRIOR TO COMMENCING INSTALLATION, THE USER SHOULD REFER TO THE SAFETY AND WARNING INFORMATION AND UNPACKING INSTRUCTIONS AT THE BEGINNING OF THIS MANUAL.
- CABLES SHOULD BE ROUTED TO PREVENT ACCIDENTS, DAMAGE AND ACCIDENTAL UNPLUGGING WHILE AVOIDING BEND RADII OF LESS THAN 30 MM.
- FOR FURTHER INFORMATION ON SO AND SY MODELS PLEASE REFER TO SECTION 5.
- TEMPERATURE AND HUMIDITY MUST MEET THE SPECIFICATIONS DEFINED IN TECHNICAL SPECIFICATIONS.

### 3.1 TRANSPORT AND STORAGE INFORMATION

- Storage Temperature: -30°C to 50°C.
- If it is to be stored after use at a temperature below the coolant freezing point, ensure that all liquid coolant has been expelled from the camera.

### 3.2 MOUNTING THE NEWTON USING THE MOUNTING FLANGE

The standard Newton mounting flange has mounting holes for 4x M4 fittings. For further information, refer to the mechanical drawings in **Appendix B**. For SO models refer to **Section 5**.

### 3.3 ATTACHING TO MOUNTING POSTS

There are three holes that can be used if required with the 1/4 - UNC mounting posts with 1" spacing. For further information, refer to the mechanical drawings in **Appendix B**.

### 3.4 C-MOUNT

An optional C-mount adapter is available for standard Newton models.

### 3.5 CONNECTING THE NEWTON TO THE PC

The appropriate PCIe card should be available in the control PC.

#### USB 2.0

- Connect the USB 2.0 cable from the Newton to a suitable USB 2.0 slot on the control PC.

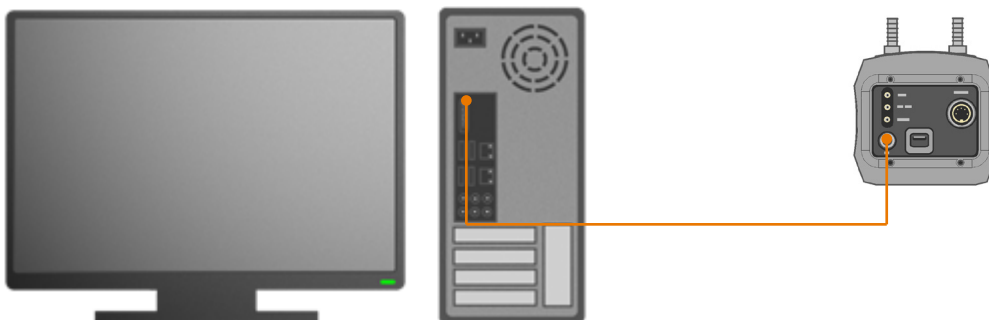

## 3.6 CONNECTING THE NEWTON TO THE POWER SUPPLY

- Connect the power cable between the Camera power input (rear panel) and the PSU.
- Connect the power cable of the PSU to the mains supply.

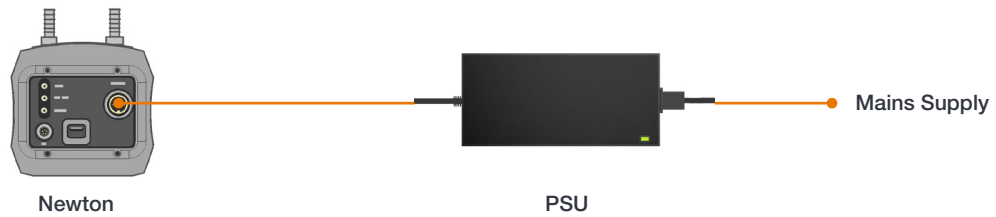

## 3.7 CONNECTING A COOLING SYSTEM

The Newton can use either air cooling, or optional liquid cooling for deep cooling.

### 3.7.1 IMPORTANT CONSIDERATIONS WHEN USING LIQUID COOLING SYSTEMS

- Before attempting to remove the coolant hoses, ensure that all coolant has been drained from the hoses and integral coolant channel within the camera head.
- Care must be taken to avoid permanent damage to the camera system resulting from either leakage of coolant during connection/removal of hoses or spillage of any residual coolant contained within the camera head once the hoses have been removed.
- Always ensure that the temperature of the liquid coolant circulated through the camera head is above the dew point of the camera ambient temperature and humidity conditions. Refer to the Dew Point graph in Appendix C for guidance.
- Use of coolant at or below the dew point can result in permanent damage to the camera head, due to formation of condensation on internal components.
- When using a liquid cooling system it is recommended that an overpressure device is fitted to avoid leaks that may find their way to the mains electricity supply and create a hazard.
- Never use damaged, split or worn hoses.
- The coolant connectors are factory fitted and sealed, they cannot be removed.
- Always remove residual coolant from the camera head if the camera is to be stored after operation—especially if the storage conditions are below the freezing point of the coolant.

### 3.7.2 COOLING HOSE CONNECTORS

There are two cooling hose connectors that are located on the top plate of the camera for connection of the Newton to a water cooler, or re-circulator system. One end is inserted into the camera body, the other end is barbed for push-fit connection to suitable tubing.

- **Coolant Hose Connectors:** Two push-fit hose connectors are factory fitted and sealed, suitable for connection to 6 mm [0.25"] internal diameter soft PVC tubing / hose
- **Recommended tubing:** 10 mm [0.4"] outside diameter, i.e. a wall thickness of 2 mm [0.08"]. Alternative hose dimensions and materials should be thoroughly tested to ensure a leak tight seal is achieved with the barbed connectors.

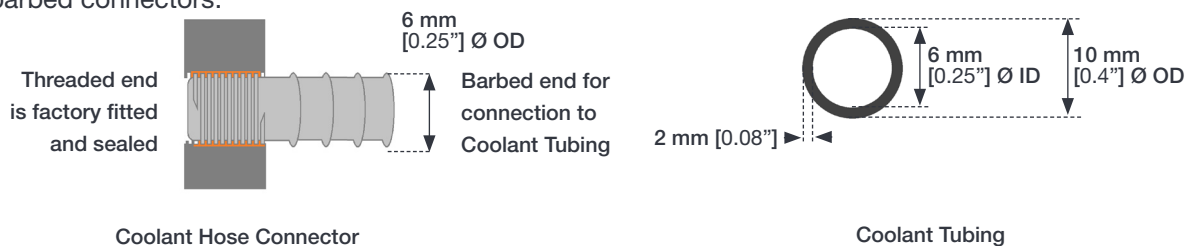

## 3.8 COOLANT RECOMMENDATIONS

- **Coolant temperature:** Refer to the temperatures specified in Technical Specifications for the specific model. Note that cooling performance may be affected by distance between camera head and cooler.

- **Recommended coolant:** water or water/glycol mix depending on the ambient environmental temperature during operation.

De-ionized water (without additives) may be used as the coolant. Some mains supply water is heavily mineralized (i.e. “Hard”) which could cause deposits in the water circuit inside the camera. This can reduce the flow-rate and cooling efficiency. The specified cooling performance of the camera can be achieved with coolant flow rates of 2 litres per minute, the maximum recommended pressure of coolant circulating through the camera head is 2 bar (30 PSI).

## 3.9 CONNECTING THE LIQUID COOLING SYSTEM

An overview for connecting a liquid cooling system is outlined below- please refer to the information supplied with your cooling system for further information.

### 3.9.1 CONNECTING THE COOLANT HOSES



1. Remove the black rubber protective caps (x2) if fitted.



2. Press the hoses onto the connectors on the camera.



3. Confirm the hoses are connected securely.
4. Connect the other ends of the coolant hoses to the cooling system- refer to the cooling system manual.

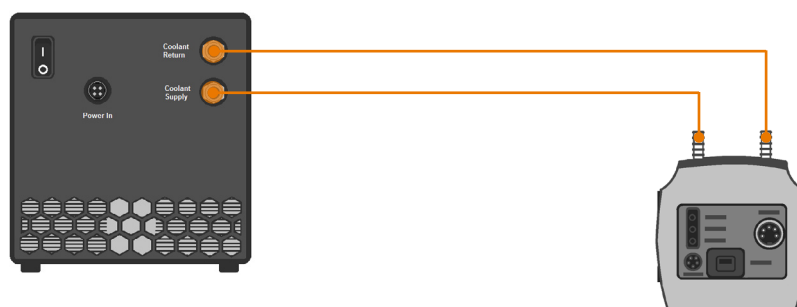

---

## 3.9.2 DISCONNECTING THE COOLANT HOSES

### Notes:

- **Push-fit, barbed fittings are not intended for repeated disconnection/connection.**
  - **Fittings are sealed during production and should not be removed from the camera body.**
1. Apply pressure and remove the tubing with a twisting motion, while holding the camera body.
  2. Once disconnected, the tubing should be inspected for cracks or stretching. It may be necessary to cut the end section of tubing so that a tight seal can be obtained.

## 3.10 INSTALLING SOFTWARE AND USB DRIVERS

### 3.10.1 MINIMUM COMPUTER REQUIREMENTS

- 3.0 GHz single core or 2.4 GHz dual or quad core processor
- 2 GB RAM
- 100 MB free hard disc to install software
- Windows (7, 8, 8.1 and 10) or Linux

### 3.10.2 INSTALLING SOLIS SOFTWARE AND USB DRIVERS

1. Terminate & exit any applications which are running on the PC.
2. Run the setup .exe from the supplied copy or the downloaded file: e.g. AndorSDK2Setup-<version>.exe.
3. Select appropriate location for installation of software and drivers on your computer / network.
4. When prompted, select Newton.
5. Continue installation and restart your computer - when prompted - to successfully complete the installation.
6. The shortcut icon for Solis will appear on the desktop on re-start.
7. The Newton is now ready to be connected to a PC / laptop and powered on.

### 3.10.3 NEW HARDWARE WIZARD

When the Newton camera is connected to a PC for the first time, the **New Hardware Wizard** screen will appear.

1. Select the **'No, not this time only'** option then click **Next>**.
2. Select the **'Install from a list or specified location (Advanced)'** option then click **Next>**.
3. Navigate to the directory where the Andor Solis software was installed to on the PC, then click **Next>** so that the **Installation Wizard can start**.
4. Click the **Finish** button to complete the installation.

**Note:** If the camera is connected to a different USB port, steps 1 – 4 will have to be repeated on the first connection only.

5. A system message will appear to indicate that the device has been successfully installed.

**Note:** You can check that the Newton is correctly recognized and installed by opening the Device Manager (Devices and printers) in Windows, Control Panel. The Newton will show under the Devices list.

---

## 3.11 INSTALLING A USB 2.0 CARD (IF NOT PRESENT)

USB 2.0 slots (USB 3 is backwards compatible) are found on most PCs. If a USB card needs to be installed please refer to the guidelines below and instructions supplied with your Card/PC.



**Ensure your PC is powered off. Ensure anti-static precautions using anti-static strap provided. Keep all screws safe.**

1. Unplug all cables from the rear of the computer.
2. Open the PC enclosure to gain access to the expansion slots.
3. Locate a suitable PCIe slot for a **USB 2.0** cards:
4. If you are unsure which slot is correct, please consult the PC user manual.
5. Remove the filler bracket corresponding to the slot you intend to use.
6. Remove the PCIe card carefully from its protective ESD packaging and insert the card connector fully into the expansion slot.
7. Ensure the card's mounting bracket is flush with any other mounting or filler brackets to either side of it, then secure the controller card in place.
8. Fit the computer panels and any accessories that you were using previously.

---

## SECTION 4: OPERATION

### WARNINGS:

- IF THE EQUIPMENT IS USED IN A MANNER NOT SPECIFIED BY ANDOR OR ITS DISTRIBUTORS, THE PROTECTION PROVIDED BY THE EQUIPMENT MAY BE IMPAIRED.
- PLEASE READ THE USER GUIDES SUPPLIED WITH YOUR SYSTEM COMPONENTS AND CAMERA CONTROL SOFTWARE PRIOR TO USE.

### 4.1 EMERGENCY MAINS DISCONNECTION

In case of emergency, the disconnecting point of the equipment is the mains power cord connected to the external power supply, or the mains socket switch.

**WARNING: SWITCH OFF THE POWER AT THE MAINS SOCKET AND REMOVE THE MAINS LEAD FROM THE EXTERNAL POWER SUPPLY.**

### 4.2 POWER-UP SEQUENCE

1. Ensure that the Newton is powered on at the mains power supply.
2. Ensure that the USB 2.0 cable is connected between the camera and the PC.
3. Start up the PC.
4. Launch your camera control software e.g. Solis or SDK2
5. The camera will now start up under control of the software and you are ready to use the camera.
6. Refer to your software manual for set-up and image acquisition information.

### 4.3 POWER-DOWN SEQUENCE

1. Exit the camera control software.
2. The camera will automatically turn off.
3. Switch off power to the camera and if not using for some time, disconnect from the mains power socket.

### 4.4 USING THE NEWTON

Once set-up the Newton is controlled through the camera control software. Please refer to the information supplied with the camera control software (available separately) for further details e.g. **Andor Solis** or **SDK2**. For information on the features available with the Newton please refer to the **Appendix D Reference Information**.

#### 4.4.1 ADJUSTING THE COOLING FAN SPEED.

1. Select Fan Control from the Hardware drop-down menu.
2. Select the speed you require as necessary (this may affect the cooling ability of the CCD).

**NOTES:** After changing from High to Low, it may be necessary for the camera temperature to stabilize before acquiring data. However for optimum performance it is recommended to leave the fan setting at High. Cooling will also affect the Newton EMCCD'S Electron Multiplying Gain (if applicable).

# SECTION 5: ADDITIONAL INFORMATION FOR SO AND SY MODELS

## 5.1 NEWTON SO

- The Newton SO (DO) model has an “open” CCD sensor which is exposed to the external environment instead of being sealed behind a window as would be typical of normal models.
- An ICF flange is built onto the front of the camera for attachment to the customer’s vacuum chamber.

### 5.1.1 BEST PRACTICE GUIDELINES

#### Condensation

- It is strongly advised that the camera should not be used in a condensing atmosphere.
- If used in a condensing atmosphere the sensor **MUST** be protected, and the use of a cold finger is strongly recommended.

#### Contamination & Damage

- When not in use, the sensor chamber should be covered and sealed.
- Due to the exposed nature of the sensor, extreme care should be taken with the camera, as damage can easily occur through mishandling or by contamination.
- If the sensor becomes contaminated, due to accident or misuse, please contact Andor immediately for advice on cleaning.

#### Vacuum Operations

- NOTE: Do not operate the Newton in a vacuum that exceeds (i.e. lower pressure)  $1.33 \times 10^{-8}$  mb ( $10^{-8}$  Torr)
- Ensure that the vacuum environment to which the camera is fitted is free of water vapour and other contaminants.
- Care should also be taken to control pressure change, as sudden pressure changes can potentially cause damage to the sensor assembly.

Please refer to the Andor Technical Note: [Open-front camera flanges](#) for further details.

### 5.1.2 REMOVAL OF THE PROTECTIVE PLATE

To mount the camera on a vacuum chamber the protective cover must firstly be removed as follows.

1. Use the appropriate spanners and/or socket driver to remove the screws and nut as shown below:

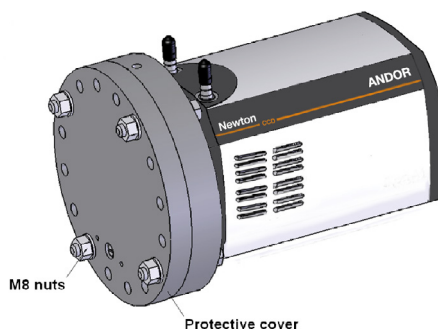



2. It is recommended that after removal of the protective cover, the camera is fitted to the chamber and evacuated immediately. The cover prevents accidental intrusion around the CCD installation and seals the sensor in a dry gas environment to minimize oxidation.
3. The camera can be fitted with an optional filter insert holder (Andor item: **FLG-SO-SY-CONVERT-45**). An insert such as a beryllium foil (Andor Item **ACC-OPT-02839**) can be fitted here in front of the detector. The holder will accept an insert of  $\text{\O} 45.5$  mm up to 1.0 mm thick.
4. To load an insert, grip the holder by hand across the flats and turn until the reference spot on the holder aligns with the reference spot on the flange, i.e.:

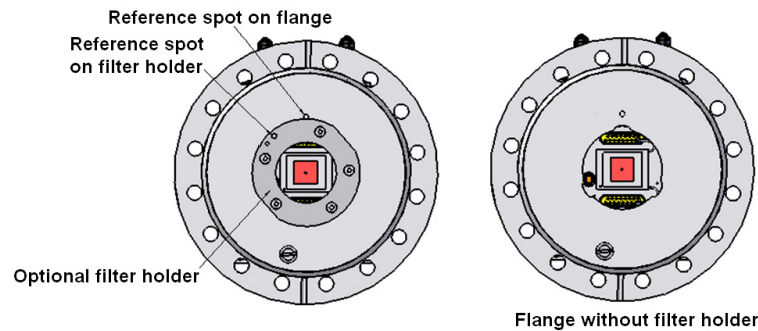

5. The holder can now be withdrawn from the flange.
6. Remove the 5 off M3 x 6 countersunk screws and lift off the upper plate of the filter holder.
7. Set the insert into the recess in the lower plate. Orientate the upper and lower plates; there is only one position where the flats and the 5 holes all align. Fasten together with the 5 off M3 x 6 countersunk screws.

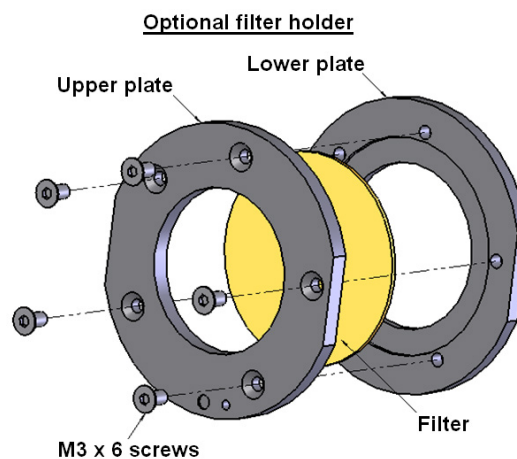

8. Re-engage filter holder in bayonet recess in SO flange and turn to achieve retention.

### 5.1.3 MOUNTING THE CAMERA ON THE VACUUM CHAMBER FLANGE

1. The SO version of the Newton is fitted with a 6" ICF flange as standard with 16 holes. The holes are on a rotatable rim which allows adjustment to match the hole pattern on the customer's vacuum chamber with either a hole indexed to the Top Dead Centre (TDC) position or with holes midway,  $(360/16)/2 = 11.25^\circ$  either side of TDC.

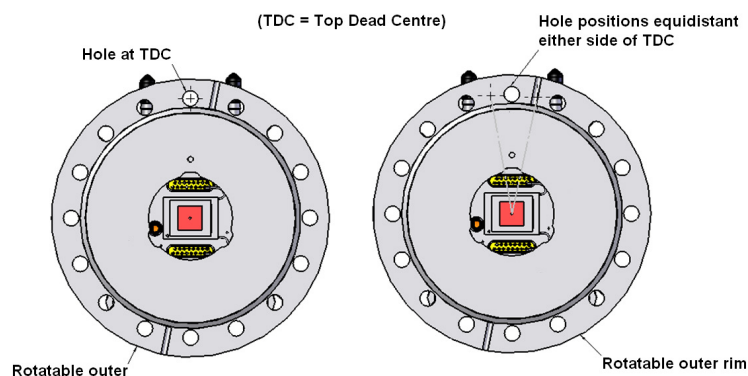

2. A ball spring plunger in the circumference of the rotatable rim will index to positions on, or either side of TDC with reference to the space between water connectors.

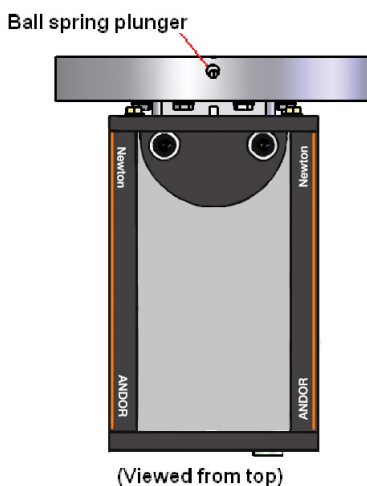

3. Up to 6 of the 16 holes may be obstructed from screw access depending on the orientation of the rim. These positions will be behind the water connectors and at the bottom corners of the camera body, i.e.:

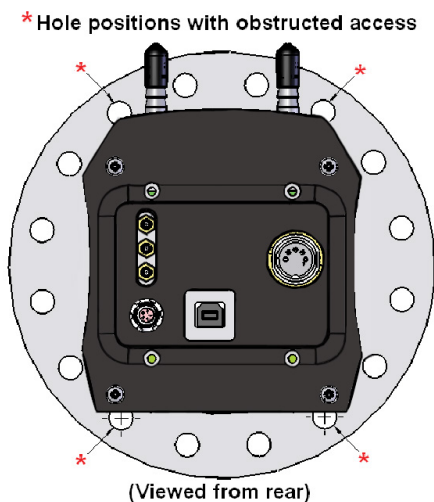

- 
4. The rotatable rim allows these holes to be moved clear of the obstructions so the screws can be loaded. The ball spring plunger may need to be loosened slightly to allow rotation.
  5. The screws used should be M8 hex head, A4 stainless steel, fitted with plain stainless steel washers of a length to suit the design of the customers flange.
  6. The screws/ washers must be inserted in the flange before the camera is fastened to the vacuum chamber since the rim will be prevented from rotation if any of the screws are fastened.
  7. Having loaded the obstructed holes, the rim needs to be rotated to the appropriate index position with the holes matching the pattern on the customer flange.
  8. The plunger can now be re-tightened to locate and lock the position. The rim may need to be rotated back and forth slightly about the required index position to verify engagement.
  9. The camera can now be assembled onto the customer flange. An open ended wrench is required to tighten the M8 screws. Please observe the torque pattern recommended for the ICF 152.

## 5.2 NEWTON SY

- The Newton SY model has a beryllium foil window as opposed to a standard window. This enables direct “soft” X-ray detection

### 5.2.1 BEST PRACTICE GUIDELINES

- When not in use the window should be covered and protected.
- Not suitable for mounting to vacuum chamber.
- Due to the exposed nature of the window, care should be taken with the camera, as damage can easily occur through mishandling or by contamination.
- If due to accident or misuse the window becomes contaminated, please contact Andor immediately for advice on cleaning.



The beryllium foil window is very brittle therefore extreme care should be taken to avoid shock damage. If the foil is broken there is a health risk. Please contact Andor for further information if required.

# SECTION 6: EMCCD MODEL INFORMATION

## 6.1 EMCCD TECHNOLOGY

Advances in sensor technology have led to the development on a new generations of sensor such as the ultra-sensitive, low light EMCCDs from in Andor Newton and iXon cameras. At the heart of your Newton detector is a **Electron Multiplying Charged Coupled Device (EMCCD)** - capable of single photon detection. An **EMCCD** is a silicon-based semiconductor chip bearing a two-dimensional matrix of photo-sensors or **pixels**.

This matrix is usually referred to as the image area. The pixels are often described as being arranged in rows and columns, the rows running horizontally and the columns vertically.

The EMCCD in the Newton detector is identical in structure to a conventional **CCD** but with the **shift register** extended to include an additional section, the **Multiplication (or Gain) Register** as shown in the figure below:

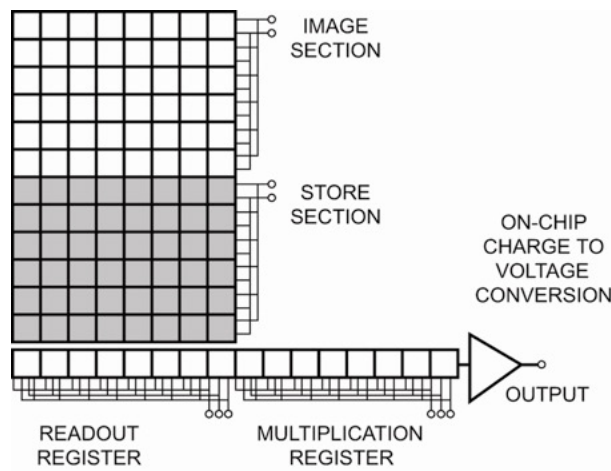
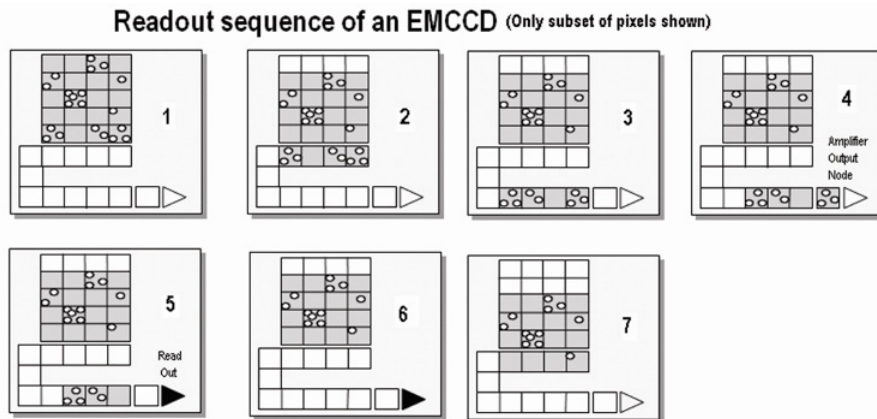

Figure 4: Typical EMCCD structure

### 6.1.1 READOUT SEQUENCE OF AN EMCCD

In the course of **readout**, charge is moved vertically into the shift register, and then horizontally from the shift register into the output node of the amplifier. The simple readout sequence illustrated below (which corresponds to the default setting of the **Full Resolution Image** binning pattern) allows data to be recorded for each individual element on the EMCCD-chip. Other binning patterns are achieved by summing charge in the shift register and/or the output node prior to readout.



- 1 Exposure to light causes a pattern of charge (an electronic image) to build up on the frame (or Image Area) of the EMCCD-chip.
- 2 Charge in the frame is shifted vertically by one row, so that the bottom row of charge moves into the shift register.
- 3 Charge in the shift register is moved horizontally by one pixel, so that charge on the endmost pixel of the shift register is moved into the Gain register.
- 4 Charge is shifted into the output node of the amplifier.
- 5 The charge in the output node of the amplifier is passed to the analog-to-digital converter and is read out.
- 6 Steps 3 and 4 are repeated until the shift register is emptied of charge.
- 7 The frame is shifted vertically again, so that the next row of charge moves down into the shift register. The process is repeated from Step 3 until the whole frame is read out.

## 6.1.2 IMPACT IONISATION

One of the electrodes (phases) in the Gain Register is replaced with two electrodes, the first is held at a fixed potential and the second is clocked as normal, except that much higher voltages (between 40V and 60V amplitude) are used than are necessary for charge transfer alone. The large electric field generated between the fixed voltage electrode and the clocked electrode, is sufficiently high for the electrons to cause **impact ionisation** as they transfer.

The impact ionisation causes the generation of new electrons, i.e. **multiplication or Gain**. The multiplication per transfer is actually quite small, only around  $\times 1.01$  to  $\times 1.015$  maximum, but when done over a large number of transfers substantial gain is achieved. By inserting the electron amplification stage before the output amplifier the signal may be increased above the readout noise, hence effectively reducing the readout noise.

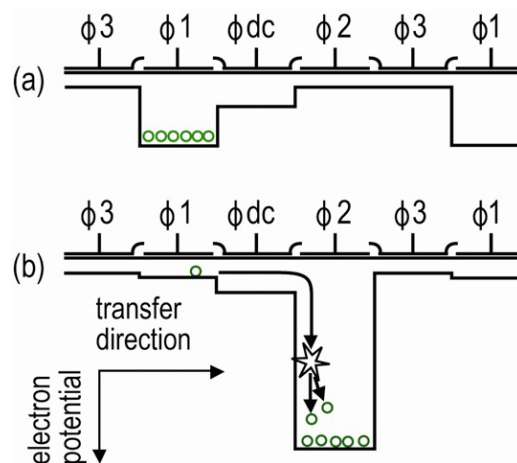

Figure 5: Gain Register Operation

The **shift register** runs below and parallel to the light collecting rows. It has the same number of pixels as a light-collecting row, but is masked, to prevent light from falling on it. The gain register is also masked. When light falls on an element, electrons (photoelectrons) are produced and, in normal operation, these electrons are confined to their respective elements. Thus, if an image (or any light pattern) is projected on to the array, a corresponding charge pattern will be produced. To capture the image pattern into computer memory, the charge pattern must be transferred off the chip, and this is accomplished by making use of a series of horizontal (i.e. parallel to the rows/ shift register) transparent electrodes that cover the array.

By suitable 'clocking', these electrodes can be used to shift (transfer) the entire charge pattern, one row at a time, down into the shift register. The shift register also has a series of **electrodes** (which are vertical, i.e. parallel to the columns) that are used to transfer the charge packets, one element at a time, into the output node of the 'on-chip' **amplifier**. The output of the amplifier feeds the Analog-to-Digital (**A/D**) converter which in turn converts each charge packet into a 16-bit binary number. The A/D converter on the Newton is located inside the camera head.

---

## 6.1.3 GAIN

### 6.1.3.1 GAIN & DYNAMIC RANGE

As the gain is increased it will at some point begin to cause a decrease in **Dynamic Range**. This occurs when the gain equals the readout noise, in electrons. Therefore at 1 MHz readout rates the Dynamic Range will be maintained at over 20,000:1 for gains up to about 20 times, whilst at 62.5 kHz it will be maintained at over 43,000:1 for gains up to 6 times.

If higher sensitivities (and hence higher gains) are required then, there will have to be a trade off for Dynamic Range. To maintain as much Dynamic Range as possible it is advisable not to use a higher gain than is necessary to measure a signal.

### 6.1.3.2 GAIN & NOISE

The output from the gain register is fed into a conventional EMCCD output amplifier. This amplifier, even in a scientific EMCCD, will have a readout noise of a few electrons rms and around 10 or 20 electrons rms at MHz readout rates. However this noise will effectively be reduced by the multiplication factor of the gain register which, when high enough, will achieve noise levels below 1 electron rms. So by using the gain you can effectively reduce the noise to insignificant levels at any readout speed. For example, the Newton EMCCD has a readout noise of a few to tens of electrons, depending on read out speed.

Using gain will itself add some noise to a measured signal due to the statistical nature of the multiplication process. A similar effect exists in EMCCDs and is referred to as the **Noise Factor**. The amount added is dependent on the signal level and the gain. If there is no gain, then there is no extra noise. At high gain (tens of times higher) it is calculated as the square root of  $N$  (where  $N$  is the signal in electrons). This will add to the shot noise of the signal to become the square root of  $2N$ . So if the signal is large enough to be above the readout noise then there is probably no need for gain and it should be reduced or turned off.

Conversely, if the signal is being lost in the readout noise then increasing the gain is the only way to detect it. If the gain is set high enough, then detection of single electron events will be possible. These events will appear on an image as a spike several hundred counts high. In Andor EMCCD cameras the gain is limited to a maximum of 255 times at  $-50^{\circ}\text{C}$  for standard systems. This is comparable to high end EMCCDs.

### 6.1.3.3 EM GAIN & TEMPERATURE

The gain of an EMCCD system varies with temperature. The graph below shows how the gain multiplication increases as the temperature decreases. Curves are shown for various software gain settings and the figures are typical values. So if a system is operated at room temperature it will have reduced gain. Because of this temperature dependence it is The graph below shows how the EM Gain setting on the software is related to the actual electron multiplication factor for various temperature settings and again the figures are typical. It is recommended that the system is cooled, so that the temperature, and hence the gain, is stabilized.

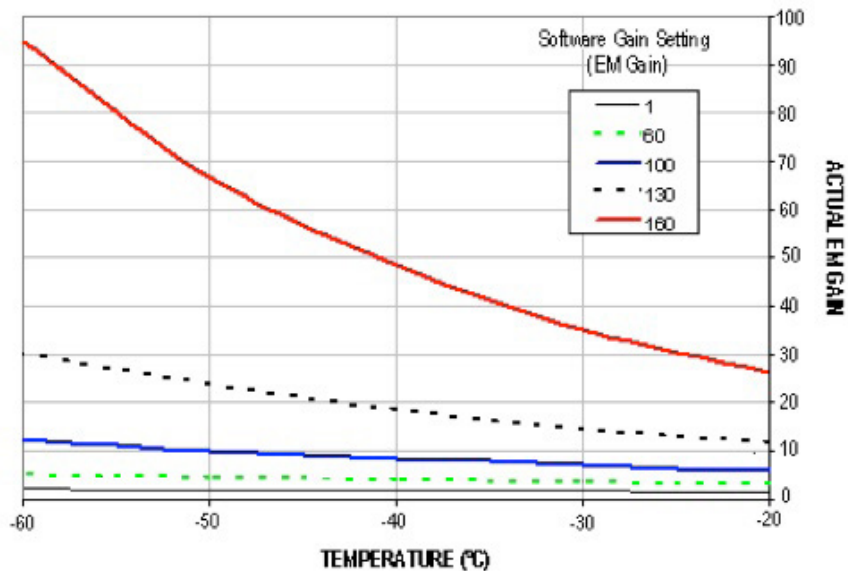

The graph below shows how the EM Gain setting on the software is related to the actual electron multiplication factor for various temperature settings and again the figures are typical.

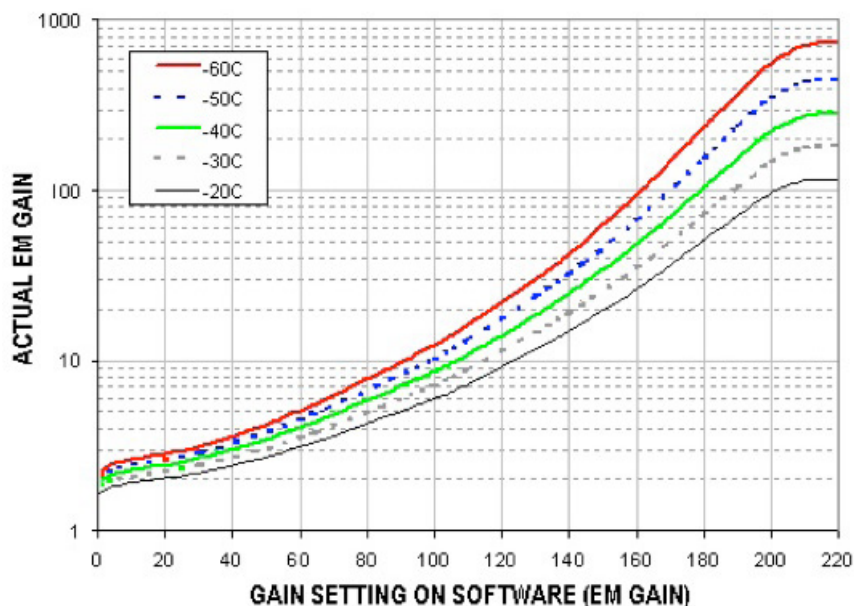

---

## 6.2 FURTHER COOLING INFORMATION FOR EMCCD MODELS

In normal operation, clocking the image and storage regions of the EMCCD sensor, along with clocking the register, generates heat. The resistive heating process is dependent on the amplitude and frequency of the clocks, therefore the faster a sensor is clocked, the more heat is generated. A TEC is capable of providing a temperature difference ( $\Delta$ ) between its cold and hot side that is dependent on the wattage of heat at the cold side (where the CCD is located). Therefore the minimum temperature the CCD can achieve is dependent on the heat produced by the sensor.

Equally, if the hot side of the TEC can be maintained at a lower temperature then the cold side will also be at a lower temperature, as the same  $\Delta$  is maintained. Air cooling the hot side achieves this by blowing air over the camera heat sink. The limitation of this is that the level of cooling is dependent on the temperature of the ambient environment. In the majority of cases this is sufficient, but if deeper cooling is necessary a water chiller or re-circulator can be employed. This will keep the hot side of the TEC at a lower temperature as the heat can be transmitted to the water more efficiently and the water temperature can also be controlled.

Any acquisition sequence that increases the proportion of the readout time spent performing vertical shifts, will have a detrimental impact on the minimum achievable cooling. The acquisition settings that have the biggest impact on cooling are:

1. **Small Regions Of Interest (ROI) for both standard and crop mode**
2. **Using vertical binning**
3. **Faster vertical shift speeds**
4. **Increased vertical clock amplitude**



## 6.3 PHOTON COUNTING

Photon Counting is a technique used to record very low-level signals that might otherwise be lost in background noise. One of the big advantages of an EMCCD is that, by setting the EM gain sufficiently high, the charge at the CCD output amplifier due to a single photon can be made many times greater than the CCD readout noise. Applying an EM Gain of several hundred can allow single photon events to be detected. These appear as single spikes that have amplitudes significantly above the read noise. When the photon flux is low, Photon Counting can be utilized. By 'low' we mean that there is little chance that two photons will arrive at the same pixel (or binned set of pixels) in the same readout period. In photon counting mode the CCD is continuously readout without any gaps between scans (so that no signal is lost). If a 'spike', corresponding to a single photon, is detected above the set threshold level then it is counted as a single event and a 1 is added in memory corresponding to that pixel position.

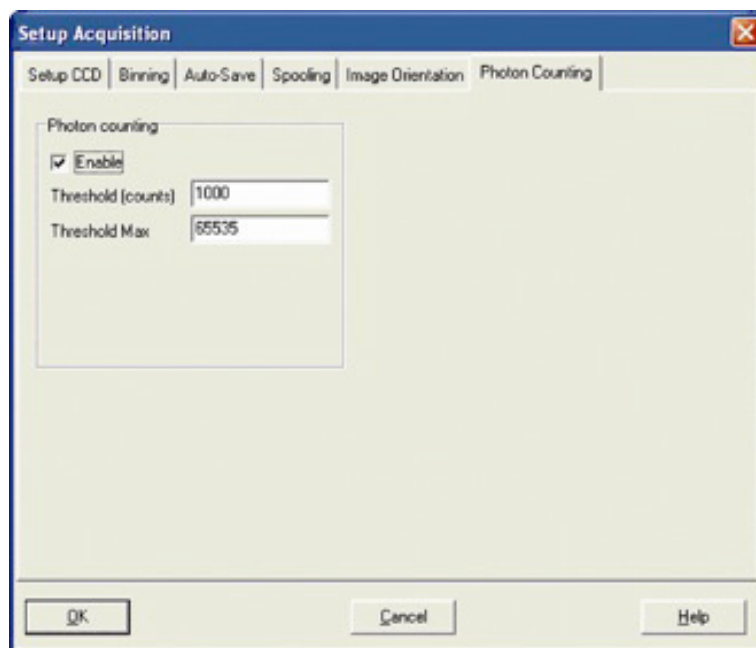

As the CCD is continually scanned, the signal builds up in memory and can be viewed live on the screen. The following traces demonstrate the dramatic improvements that are possible from this measurement method. In order to select the Photon Counting option, activate the **Enable** tick box in the **Photon Counting** area of the Setup Acquisition dialog box. A suitable threshold level must be chosen, above which any spikes arising can be counted as a single event.

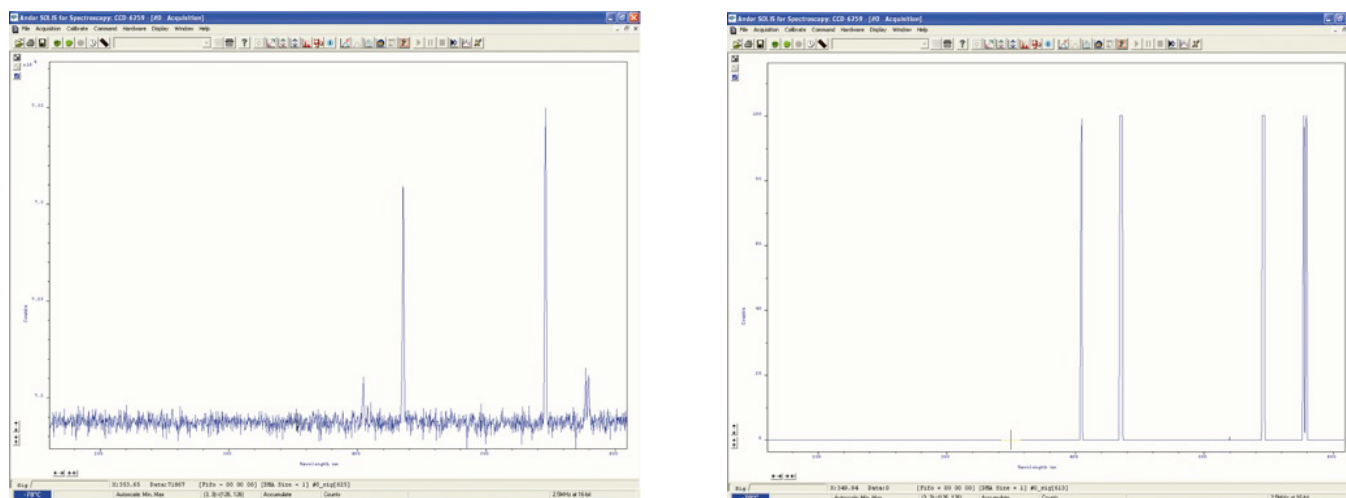

Figure 6: (Left) Normal Accumulation of 100 Scans, (Right) Photon counting with accumulation of 100 scans

---

## 6.4 OUTPUT AMPLIFIER SELECTION

The output amplifier radio button allows the user to select through which on-chip amplifier the data will pass through. The various options available (if any) will vary depending on the CCD sensor type incorporated in the camera system. In the case of Newton EM CCD systems, the user can select either the **Electron Multiplying (EM)** or **Conventional (non-EM)** output amplifier.

---

## SECTION 7: MAINTENANCE



THERE ARE NO USER-SERVICEABLE PARTS INSIDE THE CAMERA. DAMAGE CAUSED BY UNAUTHORISED MAINTENANCE OR PROCEDURES WILL INVALIDATE THE WARRANTY.

### 7.1 REGULAR CHECKS

- The state of the product should be checked regularly, especially the integrity of the PSU and the mains cable.
- Do not use equipment that is damaged.

### 7.2 ANNUAL ELECTRICAL SAFETY CHECKS

- It is advisable to check the integrity of the insulation and protective earth on an annual basis, e.g. U.K. PAT testing.
- Do not use equipment that is damaged.

### 7.3 GENERAL CLEANING & DECONTAMINATION INFORMATION

- The camera body can be cleaned with a soft cloth and dampened by water or glass cleaner.
- Never spray liquids directly on the camera; apply cleaning solution to the cloth, then wipe the camera body with the dampened cloth.
- Do not use abrasive or other detergents to clean the camera.

### 7.4 CLEANING THE CAMERA WINDOW



At some point, it may become necessary to clean debris that may have settled on the CCD imaging sensor window. Cleaning the camera window can provide effective results providing you carefully follow these step-by-step directions.

#### WARNINGS

- Only open the shutter (if present) using camera control software.
- Do not attempt to manually open the shutter (if applicable) with your fingers or other objects.
- The glass is located very close to the CCD imaging sensor. Scratching the window may require the window to be replaced.
- Cleaning the window is done entirely at the customers risk, window replacement is not covered under the warranty. It's better to under-clean than to over-clean.

---

## 7.4.1 TOOLS REQUIRED

- Compressed Air Can (or source of clean compressed air)
- Optics Brush

## 7.4.2 WINDOW CLEANING PROCEDURE

1. Remove the camera from your telescope (or other optical equipment) and place it on a clean dry surface.
2. Use the camera control software to open the shutter (if fitted).

TIP: If your program does not have this feature, try starting a long exposure. Over exposing the CCD to room light will

not damage the CCD.

Guidelines for using Compressed Air

- **If you are using a compressed air can always test-blast away from window before blowing air on the window. When you test-blast, you'll notice a spray of condensation shoot out from the can.**
  - **If condensation does form on the window, do not wipe it off. Allow it to fully dry before proceeding.**
  - **Always orient the compressed air can in an upright position before spraying.**
  - **A clean source of compressed air such as an can is recommended- do not use a compressor that may spray fine droplets of oil, or an unfiltered air supply that may spray dust particles onto the camera window.**
3. With the shutter open, turn the camera on its side making it easier for particles to fall out of the camera head Face the window toward you at the edge of a table.
  4. Give the window short blasts of compressed air to work dust particles out of the camera head.
  5. If there are still particles stuck on the window use an optics brush to very carefully dislodge them from the window surface. Then spray the dust particles out of the camera head with compressed air.
  6. Make sure to use compressed air to clean your adapter tubes and focal reducers as well so you don't get more dust once everything's assembled.

## 7.5 FUSE REPLACEMENT

In the U.K, Ireland and some other countries, the supplied mains cable has a BS 1363 (or Type G) plug that includes an integrated fuse. Only replace with fuse of the same type and rating for continued protection. The characteristics of a replacement fuse are as follows:

- **Rating:** 5A 240 VAC
- **Type:** BS 1362, size: ¼ × 1" (6.3 × 25.4 mm) cartridge

## 7.6 COOLING HOSES AND CONNECTIONS

The user should routinely check all cooling hoses and connections for signs of leakage, damage or wear. All seals must be intact before powering on camera system and any worn/damaged items must be replaced immediately.

---

## SECTION 8: TROUBLESHOOTING

### 8.1 PREVENTING CONDENSATION

**NEVER USE WATER THAT HAS BEEN CHILLED BELOW THE DEW POINT OF THE AMBIENT ENVIRONMENT TO COOL THE CAMERA.**

You may see condensation on the outside of the camera body if the cooling water is at too low a temperature or if the water flow is too high. The first signs of condensation will usually be visible around the connectors where the water tubes are attached. If this occurs carry out the following actions:

1. Switch off the system
2. Wipe the camera with a soft, dry cloth.

**NOTE: It is likely there will already be condensation on the cooling block and cooling fins inside the camera.**

3. Set the camera aside to dry for several hours before you attempt reuse.
4. Before reuse blow dry gas through the cooling slits on the side of the camera to remove any residual moisture.

Use warmer water or reduce the flow of water when you start using the device again.

**NOTE: This is not an issue when using a re-circulator which eliminates the dew point problem.**

Refer to **Appendix C** for a Dew Point Graph.

# APPENDIX A: TECHNICAL SPECIFICATIONS

(Refer to specifications sheet for model variations and performance specifications)

## General Specifications

Weight	Newton CCD, EMCCD and SY: 2.7 kg [5 lb 15 oz] Newton SO: 4.9 kg [10 lb 12 oz] Power Supply = 0.65 kg [1 lb 4 oz]
Dimensions mm [inches] W x H x D	See Appendix B

## Environmental Specifications

Usage	Indoor use only
Operating Temperature	0°C to 30 °C ambient
Storage Temperature	-25°C to 50 °C
Operating Relative Humidity	<70% (non-condensing)
Ingress Protection	IP20
Overvoltage Category	CAT II. An overvoltage category of CAT II means that the equipment is designed to cope with transient voltages above the rated supply that would be experienced by any product connected to a mains socket in a building.
Rated Pollution	Pollution Degree 2. Normally only non-conductive pollution occurs. Occasionally, however, a temporary conductivity caused by condensation must be expected.
Cooling vent clearance	100 mm minimum
Cable clearance (at rear of camera)	90 mm

## Power Requirements

Mains Input	100-240 V AC 50/60 Hz
Cable pin-outs	(see Section 2.3)
Power Consumption	48 W max

## Model Specific Information

Refer to the specification sheet for further technical and performance information required model:

- [Newton CCD](#)
- [Newton EMCCD](#)
- [Newton SO](#)
- [Newton SY](#)

# APPENDIX B: MECHANICAL DRAWINGS

## Newton CCD and EMCCD

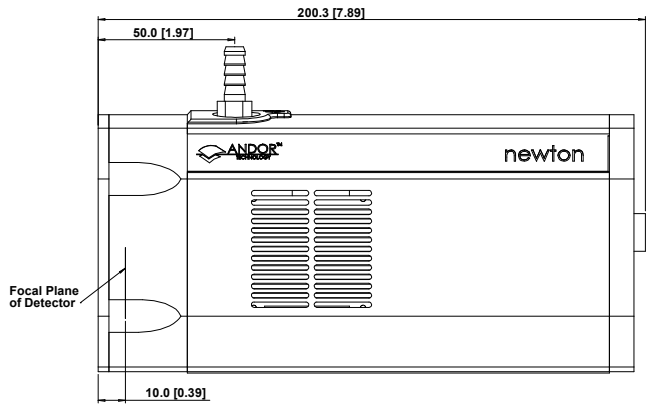
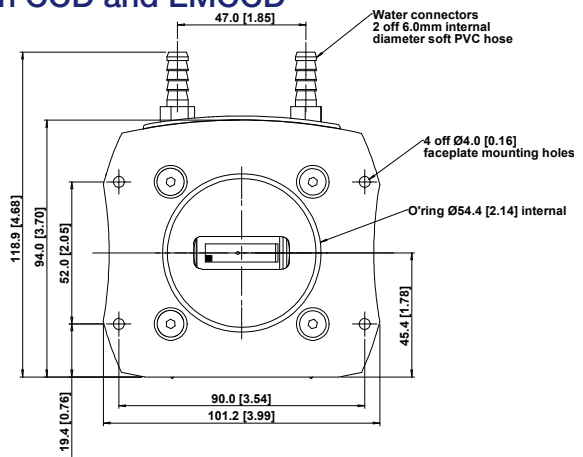

■ = position of pixel 1,1

Weight: 2.7 kg [5 lb15 oz]

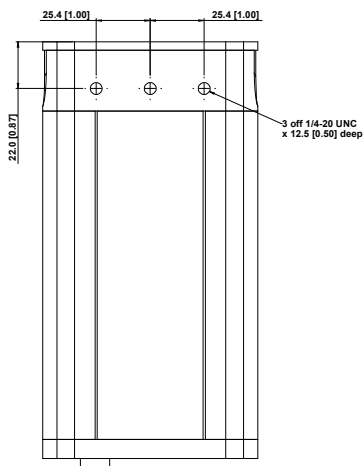

Mounting hole locations

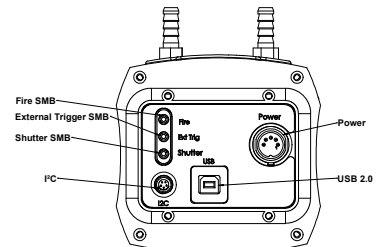

Rear connector panel

# Newton SO

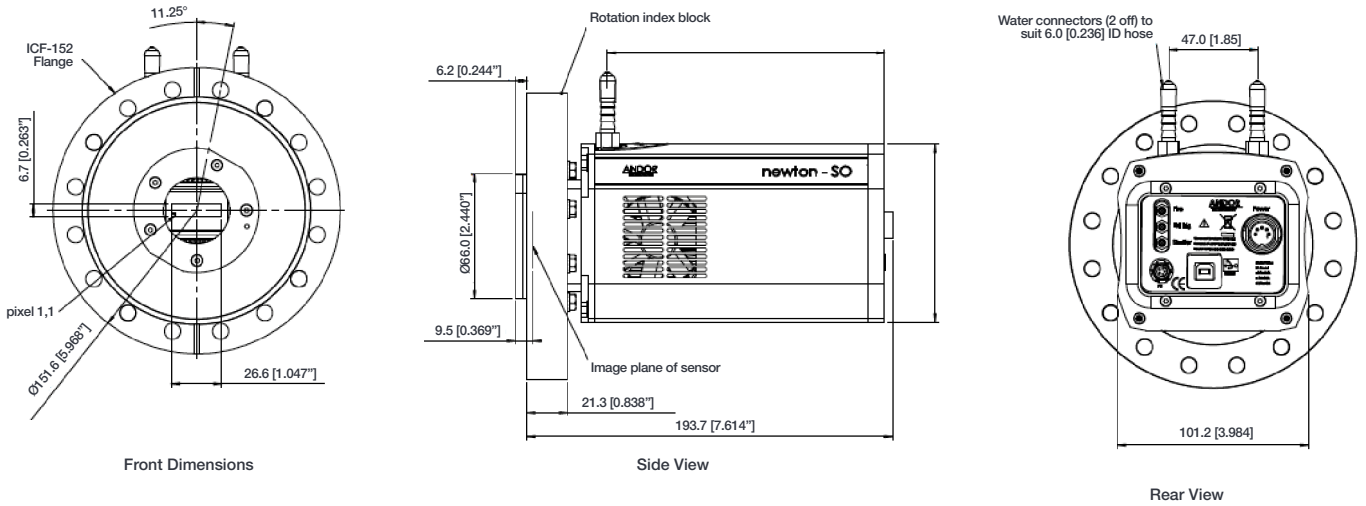

# Newton SY

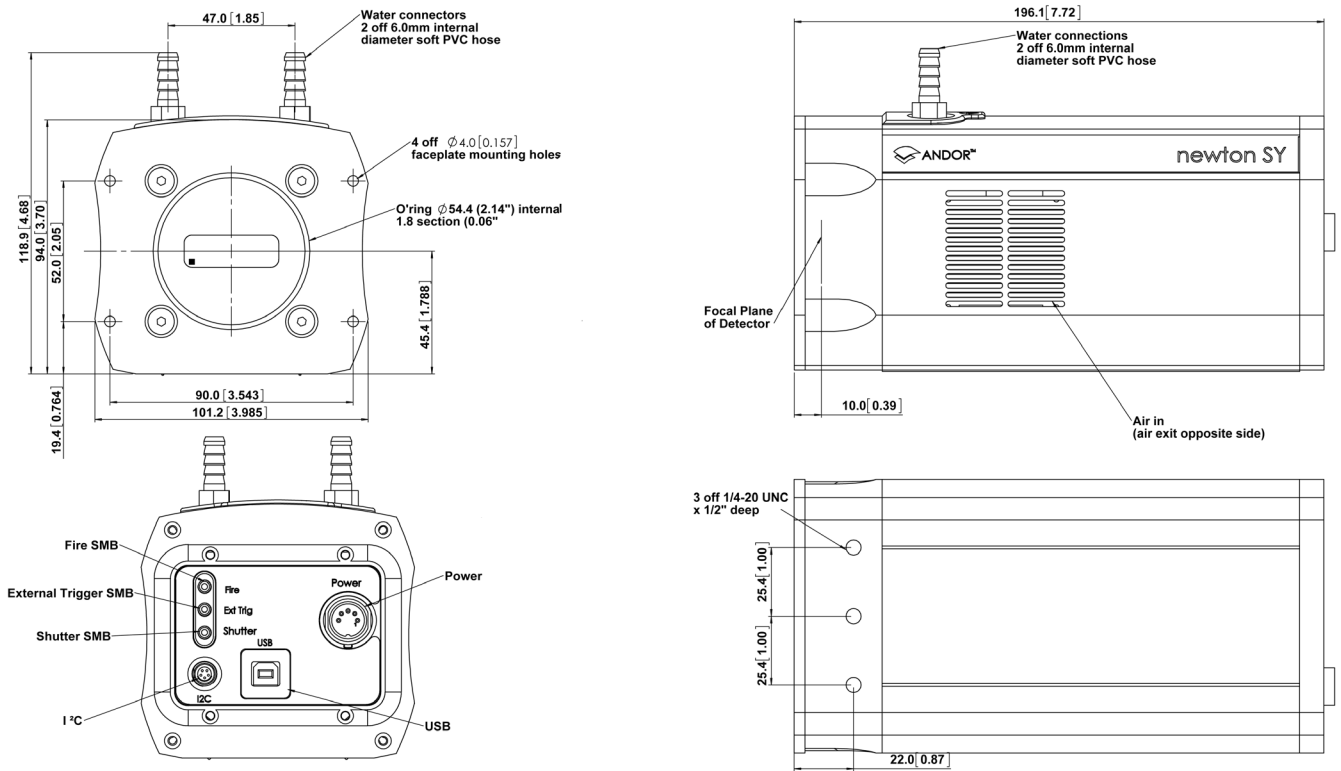



## APPENDIX C: DEWPOINT INFORMATION

To avoid issues with condensation, the coolant temperature must be set above the dewpoint- the temperature at which condensation (dew) will form. In the relatively dry conditions of an air conditioned lab, or a cool dry climate, use of a coolant temperature of 10°C should not cause any problems. As relative humidity or ambient temperature increase however, the dewpoint temperature will also increase so that the minimum coolant temperature that can be used will have to increase accordingly. This will therefore limit the maximum cooling performance that can be achieved.

The first signs that condensation is forming will be on the coolant connections entering and exiting the camera. Use of coolant at or below the dewpoint can result in permanent damage to the camera head due to formation of condensation on internal components. It is therefore very important to ensure that coolant temperature is above the dewpoint. Further guidelines are provided in **Section 8.1**. The relationship between Relative Humidity and Dew Point at varying Ambient Temperature is shown below. There is a dewpoint calculator in Solis, and also a range of dewpoint calculators on-line that you can enter ambient temperature and relative humidity to calculate the dewpoint for your conditions.

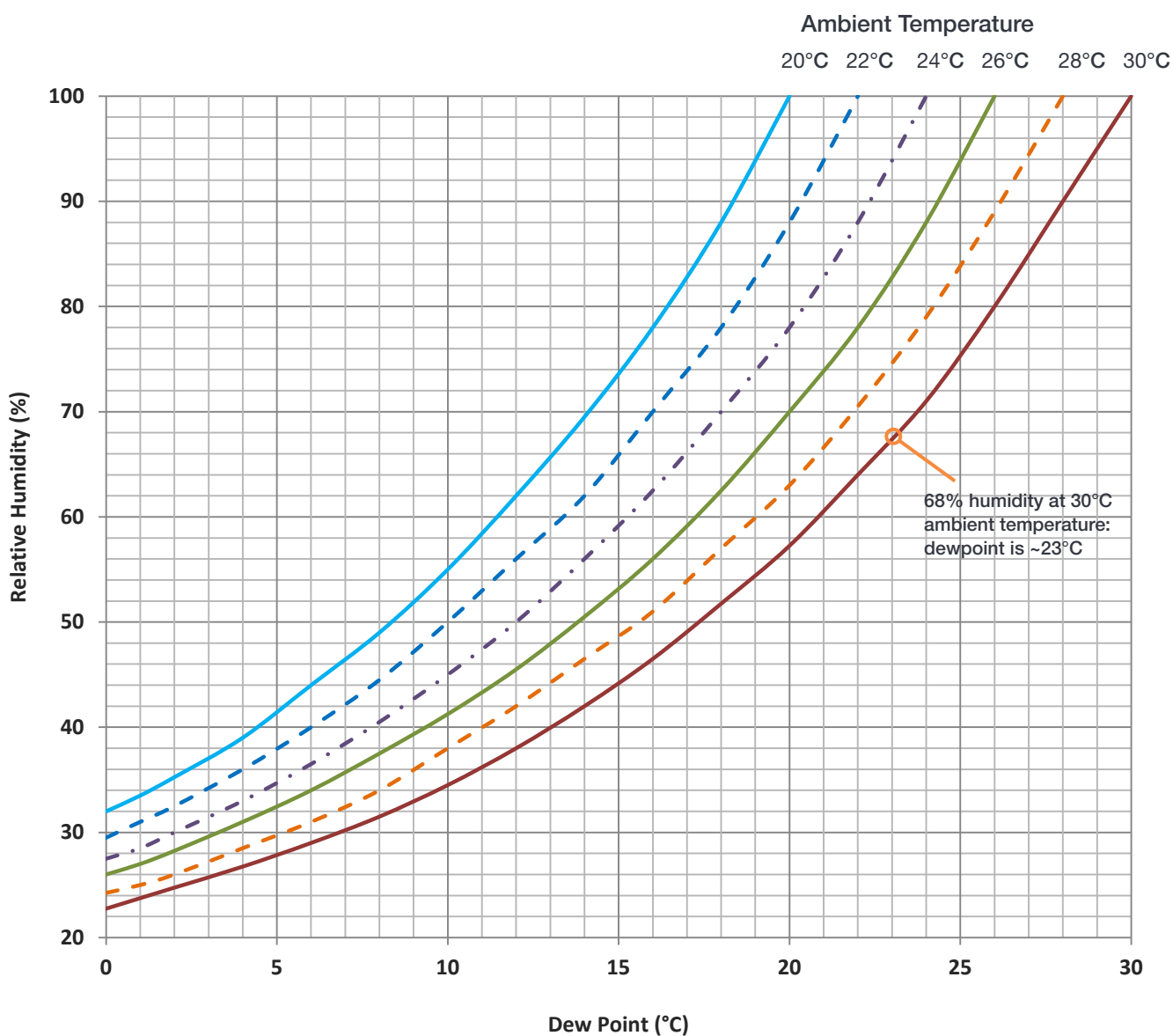

---

## APPENDIX D: REFERENCE INFORMATION

### ULTRAVAC™ TECHNOLOGY

UltraVac is Andor's proprietary vacuum technology that provides a permanent, hermetically sealed enclosure (without O-rings) for the sensor. This ensures maximum cooling performance, with a reliability proven through years of use in Andor cameras such as the iXon EMCCD, iKon and Newton series- the Mean Time Between Failure (MTBF) value is > 100 years.

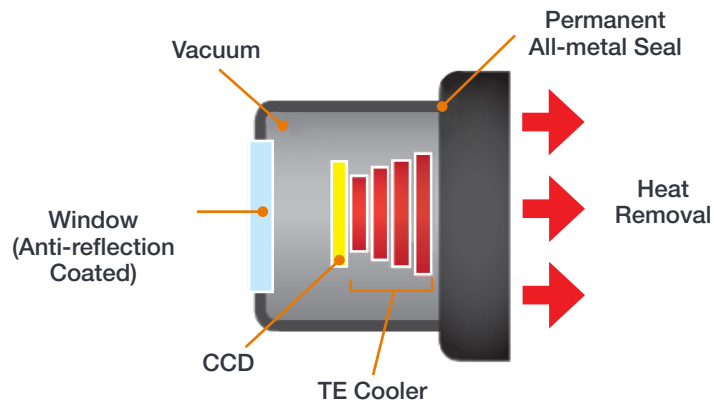

Outgassing is minimized through assembly in a state of the art facility, with a stringent protocol and use of proprietary materials (Outgassing is the release of trapped gasses that would otherwise degrade cooling performance and potentially cause sensor failure). UltraVac also features a single camera window for the best optical performance. For more information about our UltraVac technology, please visit our website and view the technical article on [UltraVac](#).

### SHUTTER AND TRIGGERING INFORMATION

For shutter (optional item) and trigger mode operation information please refer to your camera control software e.g. SDK2.

---

## APPENDIX E: OTHER INFORMATION

### E.1 TERMS AND CONDITIONS OF SALE AND WARRANTY INFORMATION

The terms and conditions of sale, including warranty conditions, will have been made available during the ordering process. The current version for the US is [available here](#), for all other regions (except Japan) please [click here](#).

### E.2 EU/UK REACH REGULATION STATEMENT

Andor's EU/UK REACH Regulation statement is available at the [following link](#).

### E.3 WASTE ELECTRONIC AND ELECTRICAL EQUIPMENT REGULATIONS 2006 (WEEE)

The company's statement on the disposal of WEEE can be found in the Terms and Conditions found on the Andor website, [WEEE Policy](#).



# APPENDIX F: NEWTON CHINA ROHS HAZARDOUS SUBSTANCES DECLARATION

Name and Content of Hazardous Substances in the Product  
 产品中有害物质的名称及含量 产品中有害物质的名称及含量

Hazardous Substance: 有害物质						
Component Name 部件名称	Lead (Pb) 铅	Mercury (Hg) 汞	Cadmium (Cd) 镉	Chromium VI Compounds (Cr <sup>6+</sup> ) 六价铬化合物	Polybrominated Biphenyls (PBB) 多溴化联苯	Diphenyl Ethers (PBDE) 多溴联苯醚
Printed Circuit Board Assemblies (Surface-mount Resistors and Capacitors, and Brass Connectors) 路板组件 电路板组件 (表面贴装电阻器和电容器 · 以及黄铜连接器)	X	O	O	O	O	O
Hex Stand-offs (see image in table below) 六角隔撑	X	O	O	O	O	O
Screw Locks (see image in table below) 螺丝锁定	X	O	O	O	O	O
All other parts 其余配件	O	O	O	O	O	O

This table was developed according to the provisions of SJ/T 11364  
 本表格依据SJ/T 11364 的规定编制

O - The content of such a hazardous substance in all homogeneous materials of such a component is below the limit required by GB/T 26572

O - 表示该有害物质在该部件所有均质材料中的含量均在GB/T 26572 规定的限量要求以下

X - The content of such a hazardous substance in a certain homogeneous material of such a component is above the limit required by GB/T 26572

X - 表示该有害物质至少在该部件的某一均质材料中的含量超出GB/T 26572 规定的限量要求

This table shows images for parts within the Newton Instrument.

