

iKon-M PV Inspector

NIR optimized CCD for high throughput In-line
Electro- and Photoluminescence Inspection of PV Cells

Key Specifications

- ✓ Active pixels: 1024 x 1024
- ✓ Sensor size: 13.3 x 13.3 mm
- ✓ Pixel size (W x H): 13 μ m x 13 μ m
- ✓ Read noise: 9 e⁻ @ 3 MHz
- ✓ Maximum cooling: -70°C
- ✓ Up to 4.4 fps (full frame)
- ✓ Active area pixel well depth (typical)
100,000 e⁻

Key Applications

- ✓ Electroluminescence Inspection
- ✓ Photoluminescence Inspection
- ✓ In-line Solar Cell Inspection
- ✓ Machine Vision



Introducing iKon-M PV Inspector



Andor's iKon-M PV Inspector is designed to offer ultimate speed and sensitivity performance for in-line Electro- and Photoluminescence Inspection, delivering > 90% QE beyond 800 nm. In standard back-illuminated CCD and EMCCD cameras, NIR light is reflected within the sensor causing interference patterns (etaloning) which significantly reduce the MTF and thus the resolution of the image. The PV Inspector is equipped with a deep depleted sensor incorporating Fringe Suppression

Technology™ which almost completely eliminates etaloning.

The 1024 x 1024 array boasts high resolution 13 μm pixels, and benefits from negligible dark current with thermoelectric cooling down to -70°C. PV Inspector offers industry highest throughput via rapid readout speeds up to 5 MHz, combined with a unique 'Dual Exposure Ring Mode' that allows fast exposure switching, without re-programming time overhead. A lockable USB 2.0 port ensures secure industry safe, vibration resistant connectivity. PV Inspector is ideally suited for very fast running PV inspection systems as found in Stringers and Cell Sorters.

Features and Benefits

Feature	Benefit
QE > 90% beyond 800 nm	Very high detector sensitivity in near infra-red
5 MHz and 3 MHz readout speeds	Rapid frame rates for high throughput cell inspection
Dual Exposure Ring Mode	Unique acquisition mode for exposure time switching
Fringe Suppression Technology™	Minimizes etaloning effects in the NIR, optimizes optical resolution
UltraVac™ #1	Critical for sustained vacuum integrity and to maintain unequalled cooling and QE performance, year after year
Single AR-coated window design	NIR optimized anti-reflection coating
Thermoelectric cooling to -70°C (air cooled)	Critical for elimination of dark current detection limit
Lockable USB connection	Ensures secure, vibration resistant connectivity
Cooling on power-up	PV Inspector does not require PC connectivity to maintain stable thermoelectric cooling
Enhanced Baseline Clamp	Essential for quantitative accuracy of dynamic measurements
13 x 13 μm pixel size	Optimal balance of dynamic range and resolution
Integrated shutter (optional)	High dynamic range and 16-bit digitization available
Andor Solis software / SDK (Linux SDK available)	Friendly Windows user interface offers intuitive acquisition optimization, system integration, automation and advanced data manipulation facilities
Integrated in EPICS	Platform is fully integrated into the EPICS control software

System Specifications^{•2}

Sensor option	BEX2-DD: Back Illuminated CCD, Deep Depletion with fringe suppression. Optimum sensor for Near IR applications.
Active pixels	1024 x 1024
Pixel size	13 x 13 μm
Image area	13.3 x 13.3 mm with 100% fill factor
Minimum temperature air cooled (25°C ambient)	-70°C
Digitization	16 bit
Blemish specifications	Grade 1 sensor from supplier. Camera blemishes as defined by Andor Grade A andor.oxinst.com/learning/view/article/ccd-blemishes-and-non-uniformities
System window type	Single AR-coated UV-grade fused silica (NIR optimised)
Interface	Lockable USB 2.0
Lens mount	C-mount (other mounts available on request)

Advanced Performance Specifications^{•2}

Dark current, $e^-/\text{pixel}/\text{sec}$ @ -70°C ^{*3}	0.14
Pixel readout rates	5, 3 MHz
Pixel well depth	100,000 e^-
Read noise (e^-) ^{*4}	
3 MHz	9.0
5 MHz	14.0
Linearity ^{*5}	Better than 99%
Vertical clock speed	4.25 to 64.25 μs (software selectable)
Dual exposure cycle time ^{*6}	500 ms
Exposure switching time	Negligible
Array size compatibility	Full image only

Frame Rates^{•7}

3 MHz					5 MHz				
Binning	Full Frame	512 x 512	256 x 256	128 x 128	Binning	Full Frame	512 x 512	256 x 256	128 x 128
1 x 1	2.6	5.2	10.0	18.6	1 x 1	4.4	8.5	16.0	28.8
2 x 2	6.3	10.9	19.3	33.2	2 x 2	8.4	15.9	28.5	47.6
4 x 4	13.4	20.9	34.2	53.5	4 x 4	15.6	28.1	47.0	70.8
8 x 8	25.1	36.3	54.4	76.5	8 x 8	27.3	45.8	69.4	93.5
16 x 16	41.5	56.1	76.5	97.1	16 x 16	43.6	66.9	91.2	111.5

Quantum Efficiency Curve ⁸

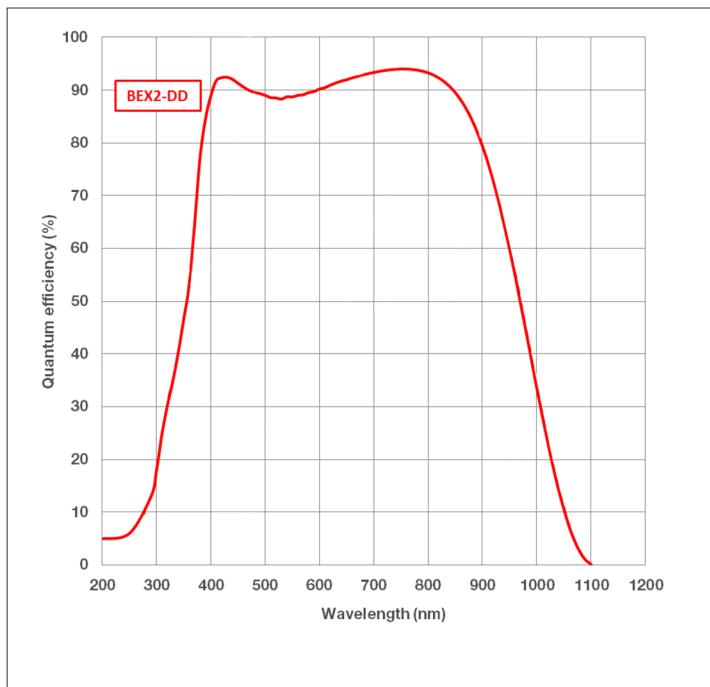

Application Image

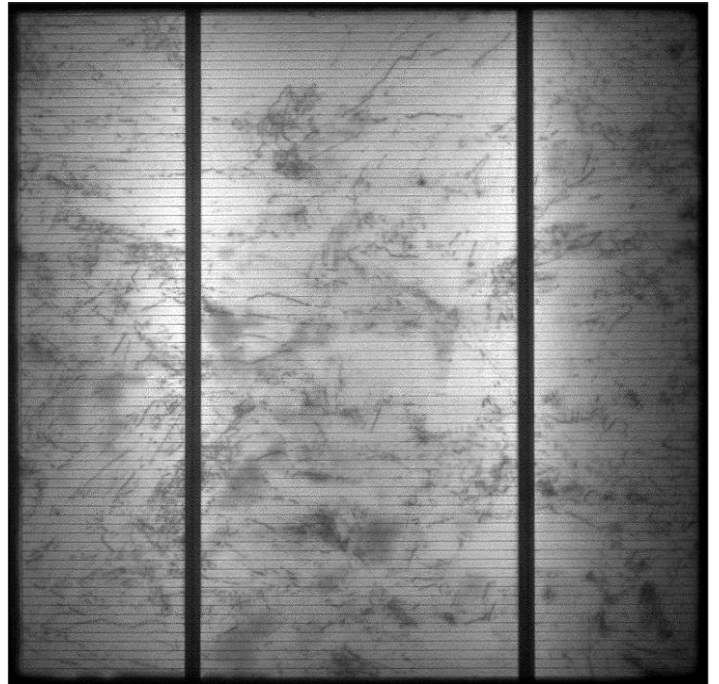

An Electro-luminescence image of a multi-crystalline photovoltaic cell taken with the PV Inspector camera. Exposure time 100 ms, read-out rate 5 MHz, total imaging-cycle time less than 350 ms.

Creating The Optimum Product for You



DU934PC **S** V-BEX2-DD
example shown

Step 1. Choose the shutter option



Shutter

Description	Code
Integrated shutter	S
No Shutter	0

Step 2. Select the required accessories and adapters



Accessories & Adapters

Description	Order Code
C-mount to Nikon AF adapter	OA-CNAF
C-mount to Olympus F-mount adapter	OA-COFM
C-mount to T-mount adapter	OA-CTOT
Auto extension tubes (set of 3) for Canon AF	OA-ECAF
Auto extension tubes (set of 3) for C-mount	OA-ECMT
Auto extension tubes (set of 3) for Nikon AF	OA-ENAF
USB Extender: Icron USB 2.0 Ranger 2201 (supports up to 100 m) - EU/UK/US	ACC-USBX-EU ACC-USBX-UK ACC-USBX-US
30 m Ethernet cable (for use with the above ACC-USBX-** USB extenders)	ACC-ELC-13295

Step 3. Select the required software



Software

The iKon-M PV requires at least one of the following software options:

Solis for Imaging A 32-bit and fully 64-bit enabled application for Windows (8.1 and 10) Linux and LabVIEW, offering rich functionality for data acquisition and processing. AndorBasic provides macro language control of data acquisition, processing, display and export.

Andor SDK A software development kit that allows you to control the Andor range of cameras from your own application. Available as 32/64-bit libraries for Windows (8.1 and 10), compatible with C/C++, C#, Delphi, VB.NET, LabVIEW, MATLAB and Python. Linux SDK compatible with C/C++.

Have you found what you are looking for?

Need a multi-megapixel solution? Loaded with FPGA intelligence, the Zyla and vacuum cooled Neo sCMOS are designed to drive optimal performance from this exciting and innovative new technology development. Unlike any CMOS or CCD technology to come before it, sCMOS sets radical new benchmarks in its unique ability to simultaneously deliver highest specifications in sensitivity, resolution, speed, dynamic range and field-of-view: high-end imaging with ultimate sensitivity. Best suited for module inspection in Laminators and Flashers.

Need a customised version? Please contact us to discuss our Customer Special Request options.

Product Drawings

Dimensions in mm [inches]

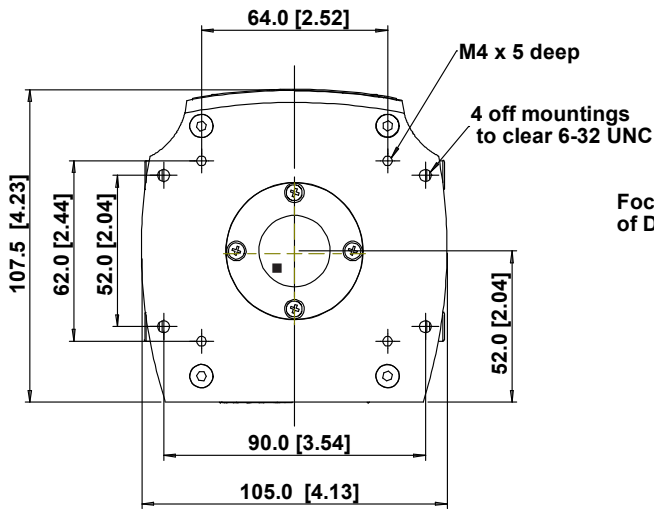
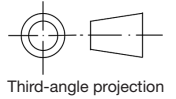

Focal Plane of Detector

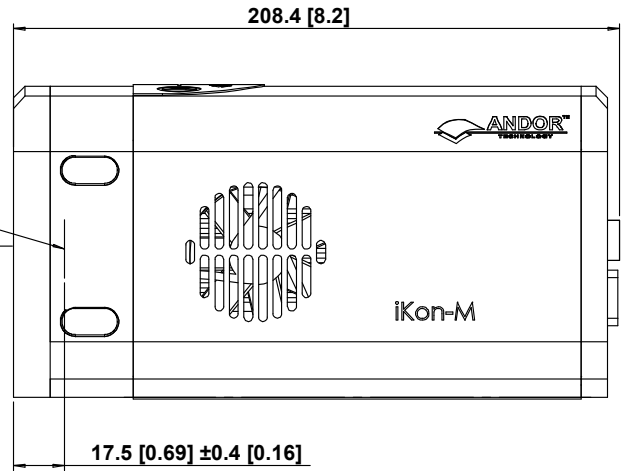

■ = position of pixel 1,1

Weight: 2.2 kg [4 lb 13 oz]

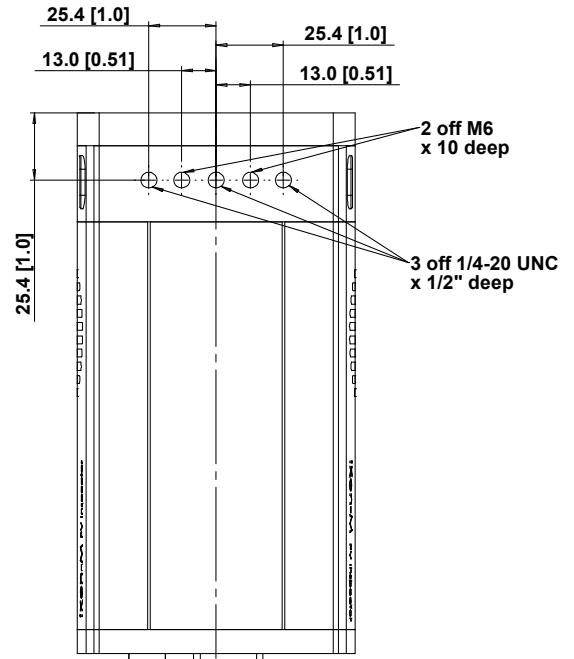

Mounting hole locations

Connecting to the iKon-M PV

Camera Control

Connector type: USB 2.0 with optional lockable connector

TTL / Logic

Connector type: SMB, provided with SMB - BNC cable
Fire (Output), External Trigger (Input), Shutter (Output)

I²C connector

Compatible with Fischer SC102A054-130
Shutter (TTL), I²C Clock, I²C Data, +5 Vdc, Ground

Minimum cable clearance required at rear of camera 90 mm

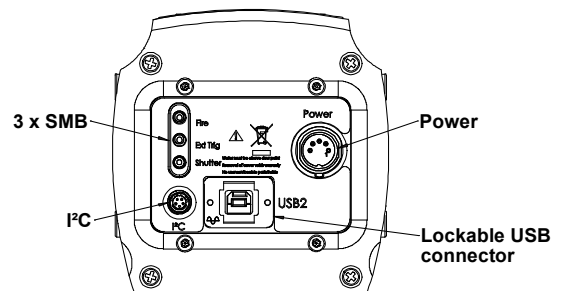

Rear connector panel

Our Cameras for High Energy Detection

Andor's portfolio of CCD, sCMOS and EMCCD cameras provide a wide range of high sensitivity, high dynamic range and fast detection solutions for table-top laboratory and beamline experiments. These detectors benefit especially applications in the field of EUV, X-ray, neutron or electron detection for material science, plasma studies, bio-samples analysis or beam/source characterisation.

Open fronted direct X-ray detection cameras

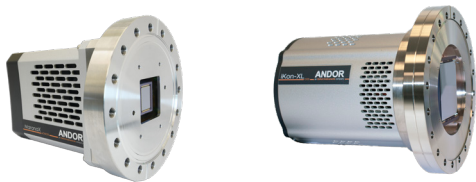

- ✓ Long exposure
- ✓ Deep cooling
- ✓ Direct detection
- ✓ Large pixel well depths
- ✓ Imaging and spectroscopy

iKon & Newton CCD & Marana-X SO ranges

Beryllium windowed direct soft X-ray detection cameras

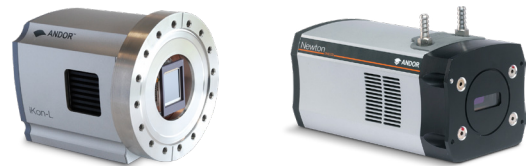

- ✓ Long exposure
- ✓ Direct detection
- ✓ Permanent vacuum
- ✓ Imaging and spectroscopy

iKon CCD, Newton CCD & iVac CCD SY ranges

Fibre-optic coupling hard X-ray detection cameras



- ✓ Fast
- ✓ Low noise
- ✓ High throughput
- ✓ Modular scintillator options

Zyla-HF sCMOS & iKon-L-HF CCD cameras

Windowed lens coupled hard X-ray & neutron detection cameras



- ✓ Fast
- ✓ Low noise
- ✓ Large area
- ✓ Deep cooled

iKon CCDs, Balor sCMOS, Zyla sCMOS, Neo sCMOS, Marana sCMOS, iXon EMCCDs

Learn more about our detector range [here](#).

Order Today

Need more information? At Andor we are committed to finding the correct solution for you. With a dedicated team of technical advisors, we are able to offer you one-to-one guidance and technical support on all Andor products.

For a full listing of our local sales offices, please see: andor.oxinst.com/contact

Our regional headquarters are:

Europe

Belfast, Northern Ireland
Phone +44 (28) 9023 7126
Fax +44 (28) 9031 0792

Japan

Tokyo
Phone +81 (3) 6732 8968
Fax +81 (3) 6732 8939

North America

Concord, MA, USA
Phone +1 (860) 290 9211
Fax +1 (860) 290 9566

China

Beijing
Phone +86 (10) 5884 7900
Fax +86 (10) 5884 7901

Items shipped with your camera

2x 5 m BNC - SMB connection cable
1x 5 m Lockable USB 2.0 cable Type A to Type B
1x Power supply with mains cable
1x electronic copy of Andor user guides
1x Individual system performance booklet

Minimum Computer Requirements:

- 3.0 GHz single core or 2.4 GHz multi core processor
- 2 GB RAM
- 100 MB free hard disc to install software (at least 1 GB recommended for data spooling)
- USB 2.0 High Speed Host Controller capable of sustained rate of 40MB/s
- Windows (8.1 and 10) or Linux

Operating & Storage Conditions

- Operating Temperature: 0°C to 30°C ambient
- Relative Humidity: < 70% (non-condensing)
- Storage Temperature: -25°C to 50°C

Power Requirements

- 100 - 240 VAC, 50 - 60 Hz

Footnotes: Specifications are subject to change without notice

1. Assembled in a state-of-the-art cleanroom facility, Andor's UltraVac™ vacuum process combines a permanent hermetic vacuum seal (no o-rings), with a stringent protocol to minimize outgassing, including use of proprietary material.
2. Figures are typical unless otherwise stated.
3. The dark current measurement is averaged over the sensor area excluding any regions of blemishes.
4. Readout noise is for the entire system. It is a combination of sensor readout noise and A/D noise. Measurement is for Single Pixel readout with the sensor at a temperature of -70°C and minimum exposure time under dark conditions.
5. Linearity is measured from a plot of counts vs exposure time under constant photon flux up to the saturation point of the system.
6. The cycle time associated with Dual Exposure Ring Mode describes the time to read out two consecutive images of same or different exposure time in this mode. It assumes exposure times of 10 μ s, 5 MHz horizontal readout and 4.25 μ s vertical shift time. The cycle time would increase accordingly with use of longer exposure times, which may be of different durations. Note, this mode is only compatible with external trigger.
7. The frame rates shown are for a range of binning or array size combinations. All measurements are made with 4.25 μ s vertical shift speed. It also assumes internal trigger mode of operation and minimum exposure time.
8. Quantum efficiency of the sensor at 25°C and -70°C as measured by the sensor manufacturer.



Windows is a registered trademark of Microsoft Corporation.